

Date	Change Detail
CO -> C1 2021/05/20 2021/05/21 2021/06/01	1.change L2 to 0 OHM resistor(R67),add ESD Diode(D17/D18/D19) 2.change R54(0R->1K), R1/R3/R7(0R->33R),add C48(220pF),C59/C60(0.01UF) 3.TS Version: R12(10M->1M), XLR Version: R12/R55(10M->10K) 4.remove R60/C44/C45/C46/C47/U6, change C17(0.01UF->1.0UF),R30(27K->100K) 5.change R53(1K->2K) 6.change wireless transmitter to USB-C connector 7.change 5G_TX module to 2.4G module 8.remove D16, add R12(0R) in series with C17 9.add D16, set as DNI
C1 -> C2 2021/09/10 2021/09/29	1.Remove Q3B,R44,R45 2.Remove USB_SP_B10 3.Change C21,C22,C25,C26,C29,C37,C52,C53(0.1uF->10uF) 4.Change R39(0R->4.7K) 5.Change R54(1K->20K) 6.Change MCU I/O PA1 to control WHITE_LED 7.Change MCU I/O PA7 to detect Charge IC singal 8.Change MCU I/O PB1 to detet MUTE singal 9.Add MCU I/O PA14 control RED_LED 10.Add R29,set as LED control 11.Add C44,C45, set as TX_BOOT/TX_RESET control 12.Add MCU I/O PB9 detect TX_BOOT function 13.Add MCU I/O NRST detect TX_Reset function 1.Add L2 for ESD solution 2.Add C46,C47 8.2p 3.Change C59(0.1uF---->8.2pF) 4.Change C3,C9(470pF->100pF) 5.Remove R12A,R55,R23,R68,R69,C60 6.Add R23A,R23B,R55A,R55B,R45 set as TS or LXR Input 7.Change R5 (200K->100R) 8.Change C54(10pF---->1uF) 9.Change C6(10uF->1uF) 10.Change C2(3.3pF->8.2pF) 11.Change R6(1M->1.2K) 12.Add R4R 1.2K 13.Add R18 10M 14.Change R11(1K->10M) 15.Change D6,D16 to lower capacitance TVS. For both TS and XLR 16.Add D13,D14 to lower capacitance TVS. For both TS and XLR

Date	Change Detail
C2 -> C Final	1.add temperature monitoring circuit: add Q6/Q7/R67/R68/R71 2.add charger(/CHG) to control white LED 3.add MLCC cap 0.1uF(C60/C61) for ESD solution, add R60 4.update MCU pinout: PA7(/CHG->TS), PB1(SW_MUTE->RED_LED),PA13(Unused->SW_MUTE), PA14(RED_LED->/CHG) 5.Remove R70, add D20, 6.add "USB_DETECT", add R23/D21, update MCU pinout:PA14(/CHG ->USB_DETECT) 7.Change R5(100R) to (XLR R5A/R45A:1.5K, TS R5B/R45B:200K), R23B/R55B:510K->330K, R6/R44:1.2K->510R R52/R56: 0R->750R 8.On the battery level detect circuit change power net from VBAT to drain of Q2 (TP18):VBAT1 9.add C62/C63:10uF,C64/C65:8.2PF for TX module and ADC 10.del R16:0 ohm 11.R8 change 0603 to 0402 12.Change R60(33R)to 100R,R7 (33R) to 100R 13.add C66 for TX module 14.del R12 (0R),del R26/R48/R15/R50/R51/R24/R38(0R) 15.change D6,D13,D14,D16: D5V0X1B2LP-7 -> PESD5V0V1BL
C Final -> DV DV -> PQ	1.+3.3V ripple improvement: remove C43 2.change TX module J4: external antenna -> chip antenna 3.ESD improvement: add C60(0.1uF/50V), remove U2 1.only apply to TS, change C3: 100pF->470pF, D3: ESD Diode->0 ohm, R5B/R45B: 200K->100 ohm, R23B:330K->1M, remove C9/R55B 2.update HW version to PQ/SOR1: TS(R59 10K->22K), XLR(R58 NC->56K, R59 10K->100K) 3.remove debug connector:J1J6

	Baby Yoda Transmitter Board			Description of Changes/Notes Rev. 3.0
	Product: Baby Yoda			
	File Name: Modify history.SchDoc			
	Part Number: Part Number		Size: A3	
	Revision: 3.0.0	Drawn By: Vincent Xu	Mod By: *	
	Status: PO/SOR	Checked By: *	Mod Date: 2022/12/8	
	Lead Engineer: *	Approved By: *		
	Date: 2022/12/8	Time: 16:09:57	Sheet: 1 of 3	

TS/XLR INPUT

Audio Input

-1/4" TS Input
-XLR Input

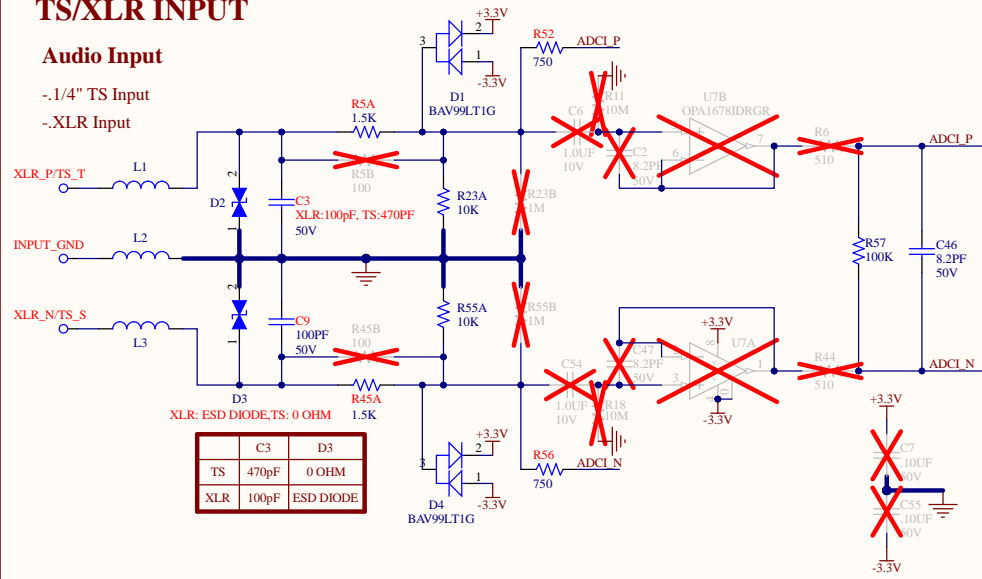

MCU

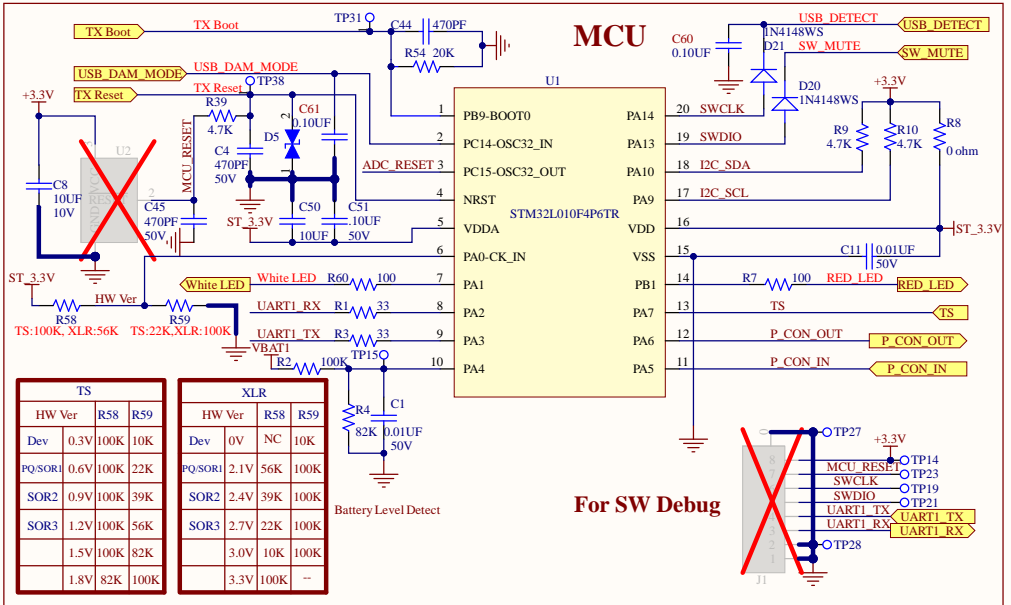

ADC

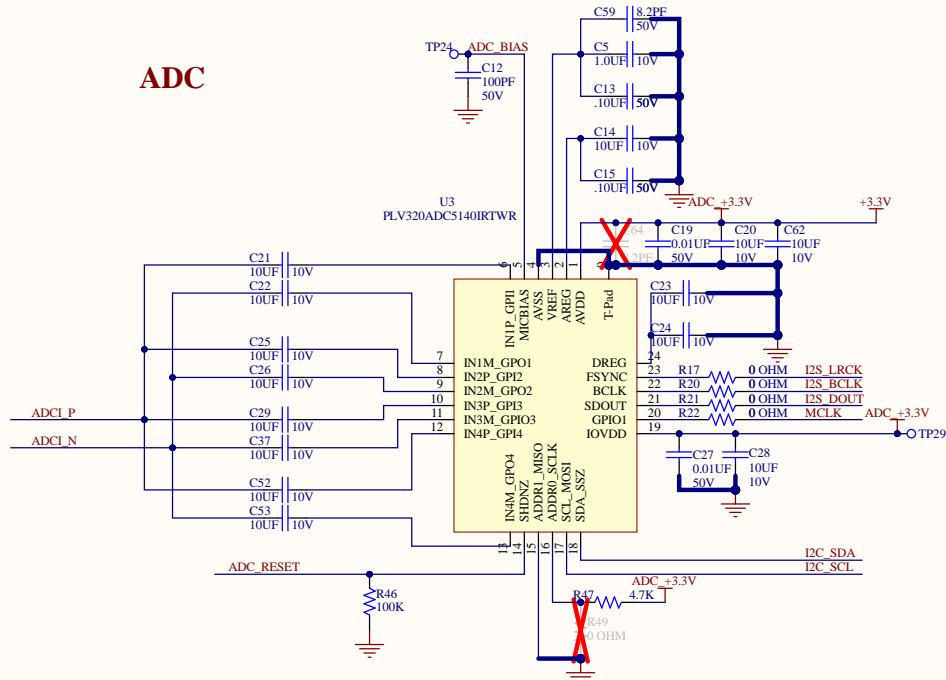

For SW Upgrade

2.4G_TX_Module

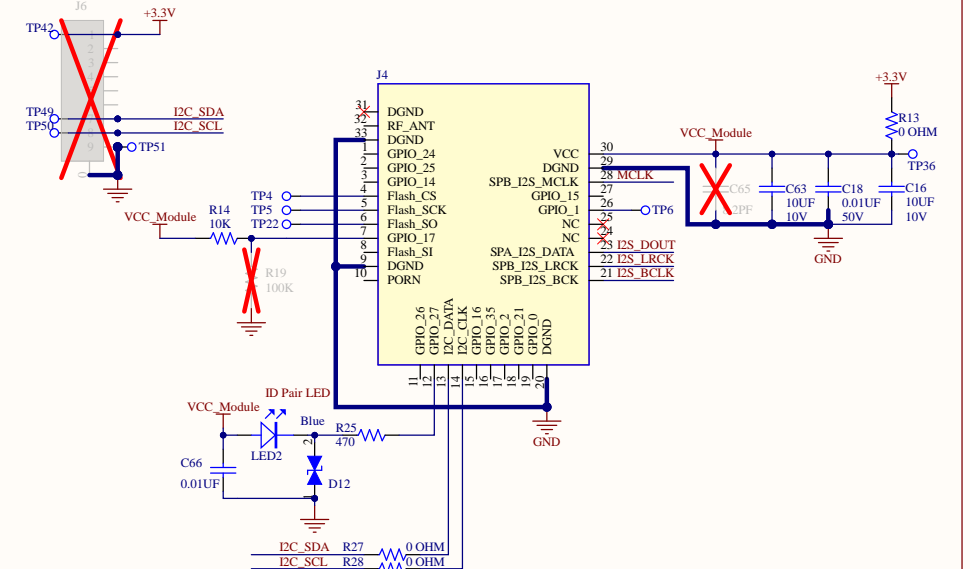

Baby Yoda Transmitter Board				Description of Changes/Notes	Rev.
Product:	Baby Yoda				
File Name:	2.4G Transmitter_Input&ADC&MCU&TX_Module.SchDoc				
Part Number:	Part Number				
Revision:	3.0.0	Drawn By:	Vincent Xu	Mod By:	*
Status:	PO_SOR	Checked By:	*	Mod Date:	2022/12/8
Lead Engineer:	*	Approved By:	*		
Date:	2022/12/8	Time:	16:09:57	Sheet:	2 of 3

3.7V Battery Pack

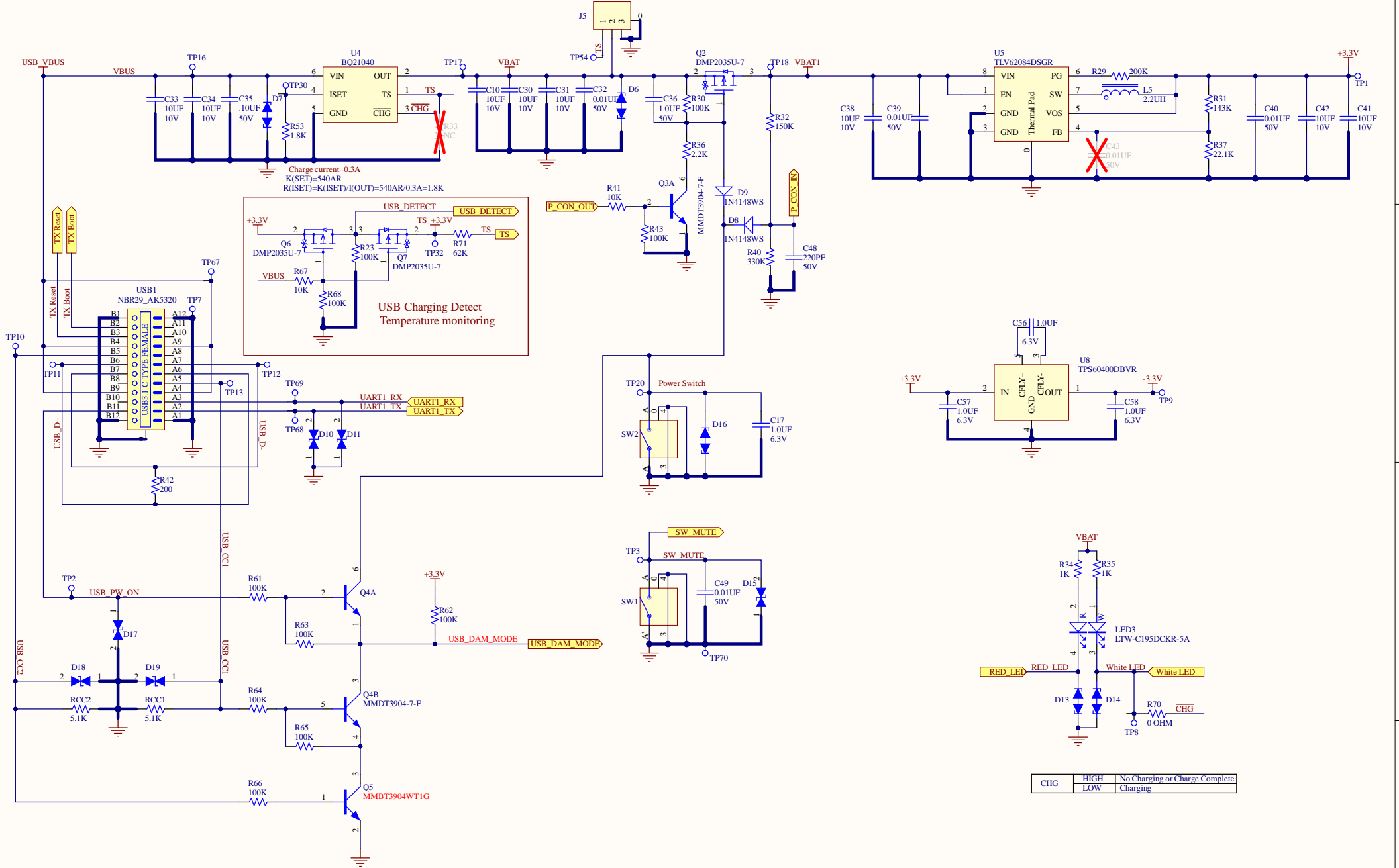

- FID1
- FID2
- FID3
- FID4
- FID5
- FID6
- FID7
- FID8

Baby Yoda Transmitter Board			Description of Changes/Notes	Rev.
Product: Baby Yoda				
File Name: 2.4G Transmitter_Power.SchDoc				
Part Number: Part Number			Size: A3	
Revision: 3.0.0		Drawn By: Vincent Xu		Mod By: *
Status: PO/SOR		Checked By: *		Mod Date: 2022/12/8
Lead Engineer: *		Approved By: *		
Date: 2022/12/8	Time: 16:09:57	Sheet: 3	of 3	

