

FRAMMINGHAM, MA 01701-9168

FreeSpace® DXA 2120 Mixer/Amp
 DSP/MCU Microprocessor PCB
 P/N: 296869 Rev. A
 Sheet 1 of 2

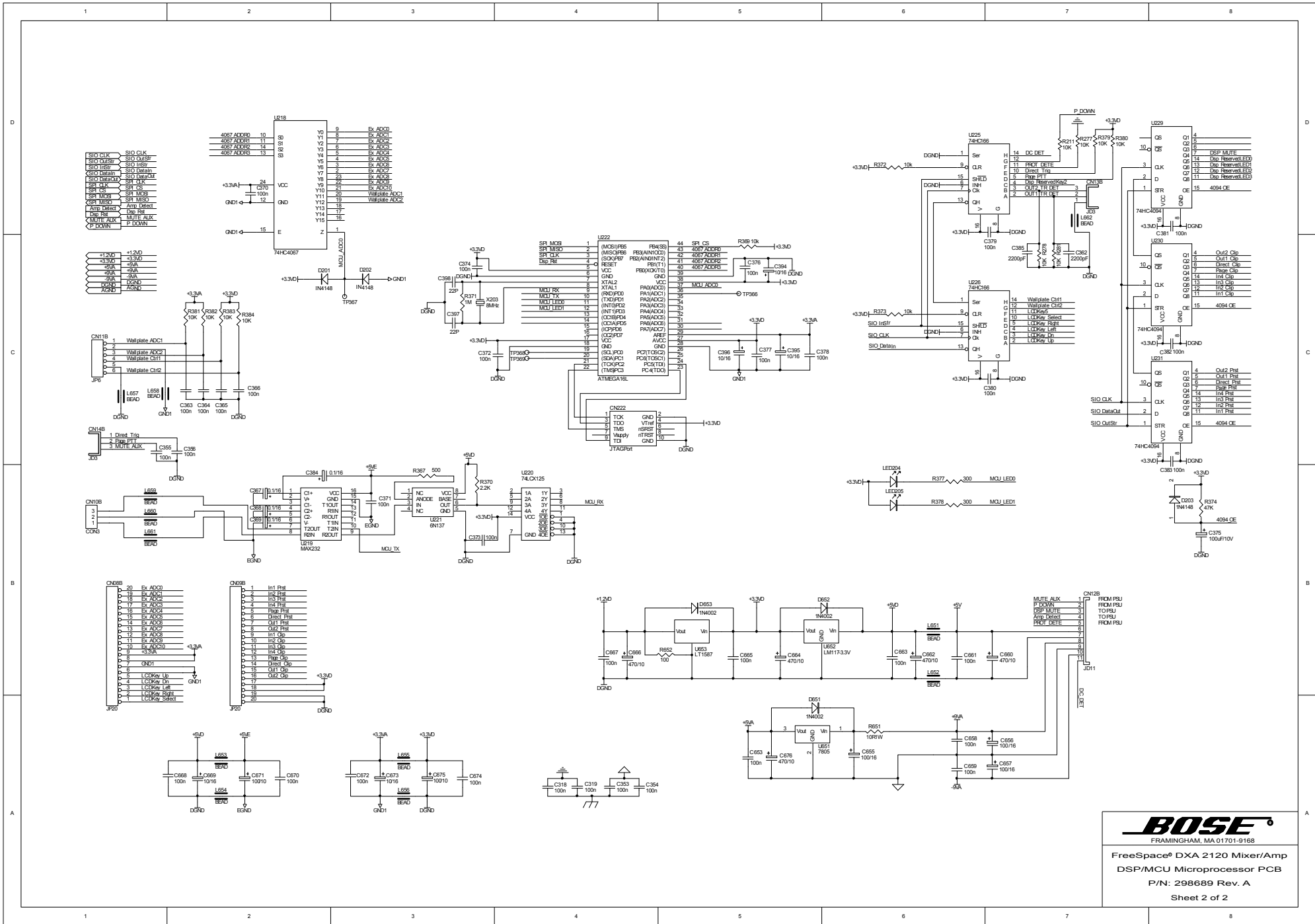

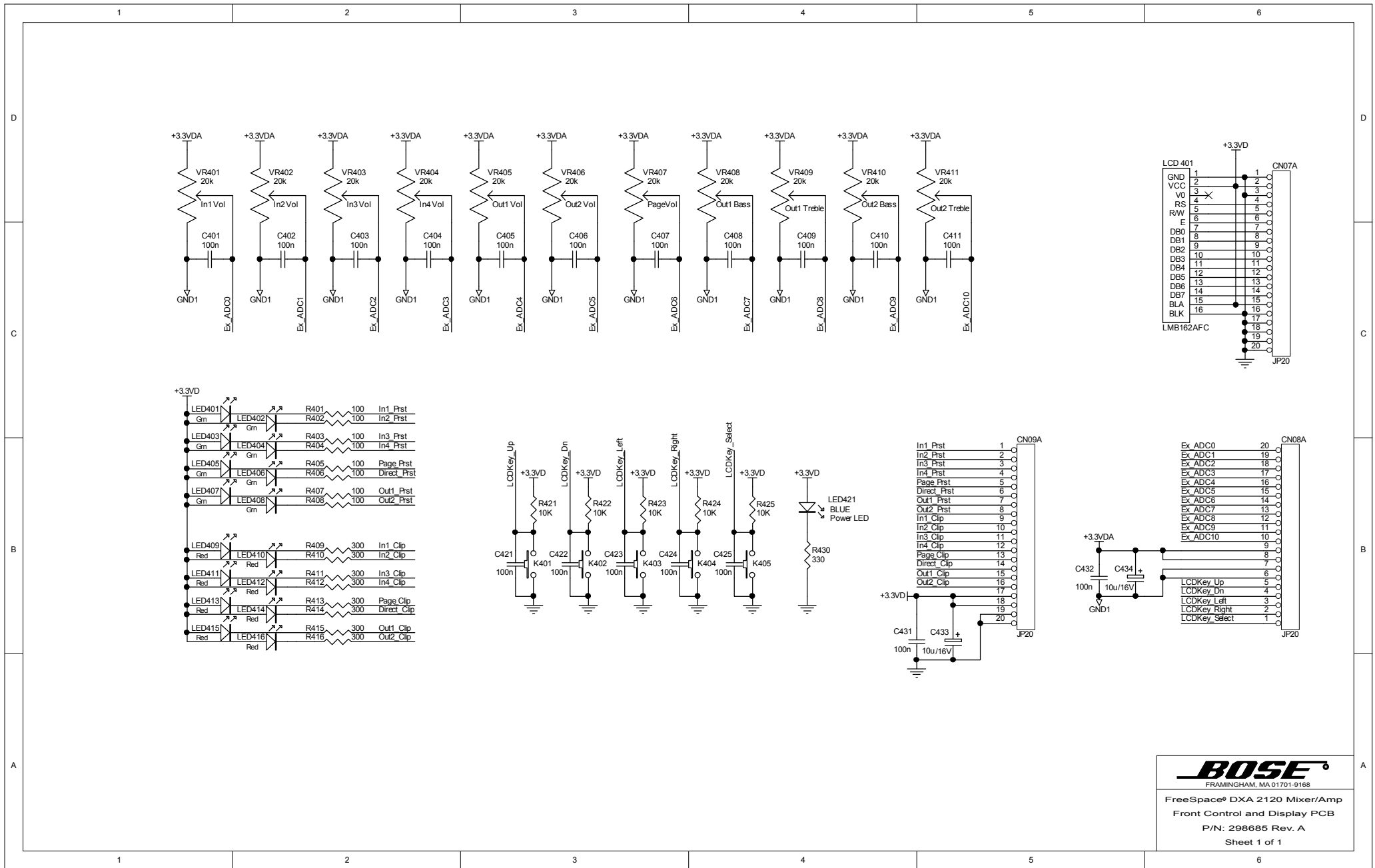

POWER AMPLIFIER PCB | SPEAKER PCB

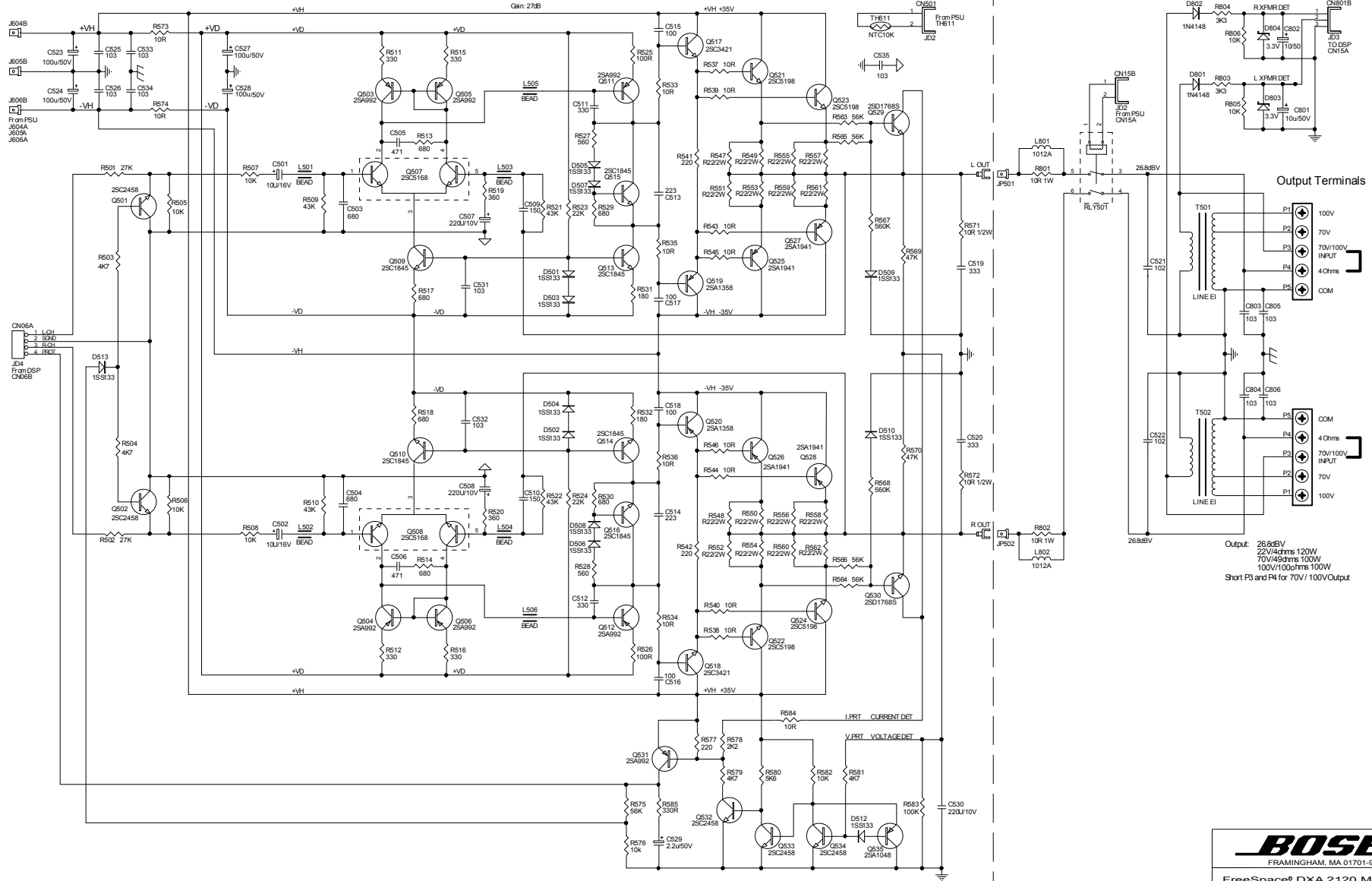

Output Terminals

P1 100V
 P2 70V
 P3 70V/100V
 P4 4 Ohms
 COM

P1 100V
 P2 70V
 P3 70V/100V
 P4 4 Ohms
 COM

Output: 26.8dBV
 22V/4ohms 120W
 70V/4ohms 100W
 100V/10ohms 100W
 Short P3 and P4 for 70V/100V Output

BOSE
 FRAMINGHAM, MA 01701-9168

FreeSpace® DXA 2120 Mixer/Amp
 Power Amplifier and Speaker PCBs
 P/N: 298695 Rev. A
 Sheet 1 of 1

