

TRIM (VR1) GAIN: 1). +14dB (+3) @ max.  
2). +2dB (-6+3.5) @ center.  
3). -6dB @ min.

PRE\_AMP & DSP, A/D, D/A, POWER SUPPLY SECTION

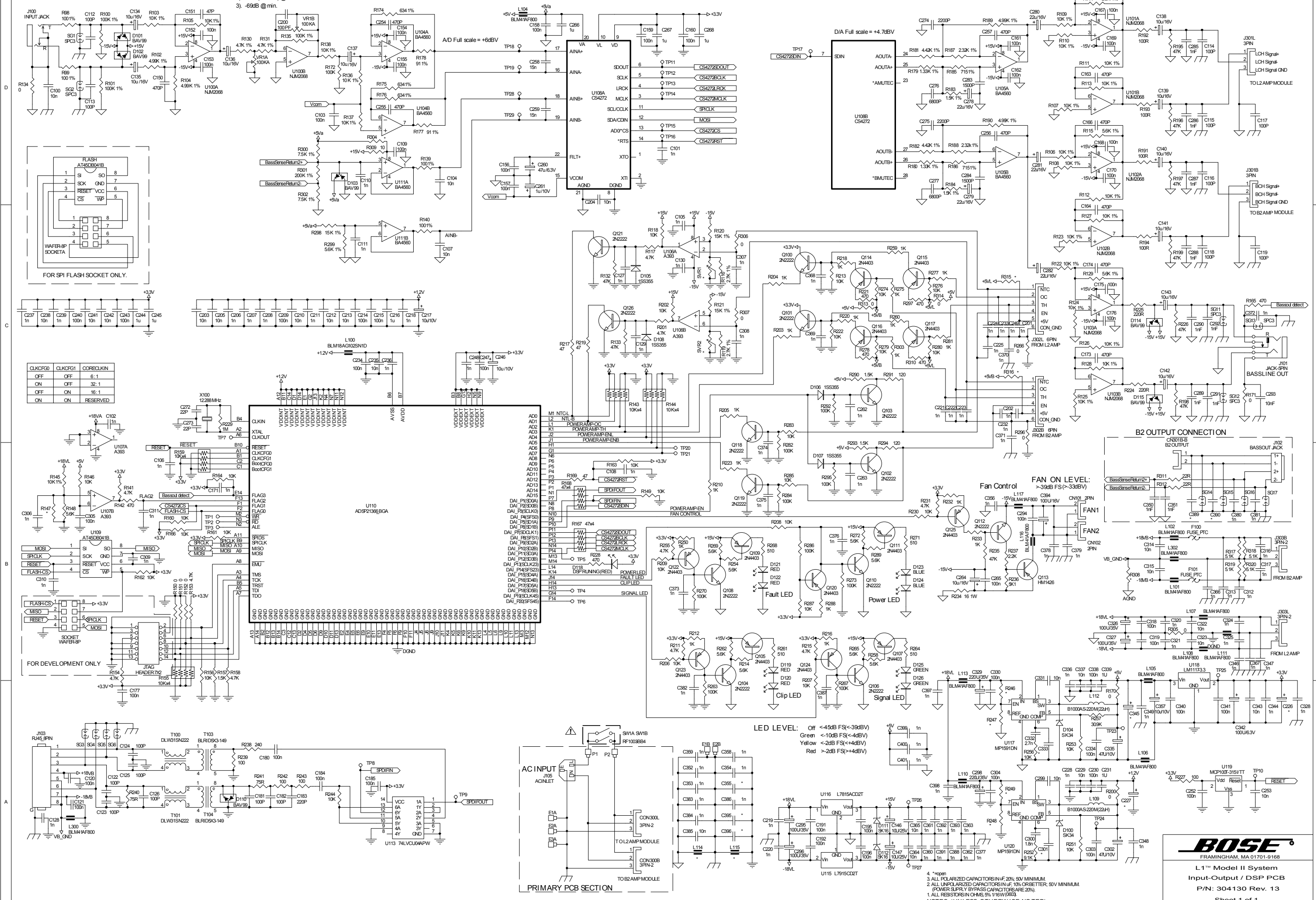

CLKCFG0	CLKCFG1	CORECLKIN
OFF	OFF	6:1
ON	OFF	32:1
OFF	ON	16:1
ON	ON	RESERVED

MOS	SI	SO	MISO
1	2	3	4
5	6	7	8

FLASHCS	MISO	RESET
1	2	3
4	5	6

SC3	SC4	SC5	SC6
1	2	3	4
5	6	7	8

VCC	5A	1A	1Y
1	2	3	4
5	6	7	8

**BOSE**  
FRAMINGHAM, MA 01701-9168

**L1™ Model II System**  
Input-Output / DSP PCB  
P/N: 304130 Rev. 13

Sheet 1 of 1

4. \*popin  
3. ALL POLARIZED CAPACITORS IN U/F, 20% 50V MINIMUM.  
2. ALL UNPOLARIZED CAPACITORS IN U/F, 10% OR BETTER, 50V MINIMUM.  
1. ALL RESISTORS IN OHMS UNLESS OTHERWISE NOTED.

# AMP MODULE FOR L2 ARRAY

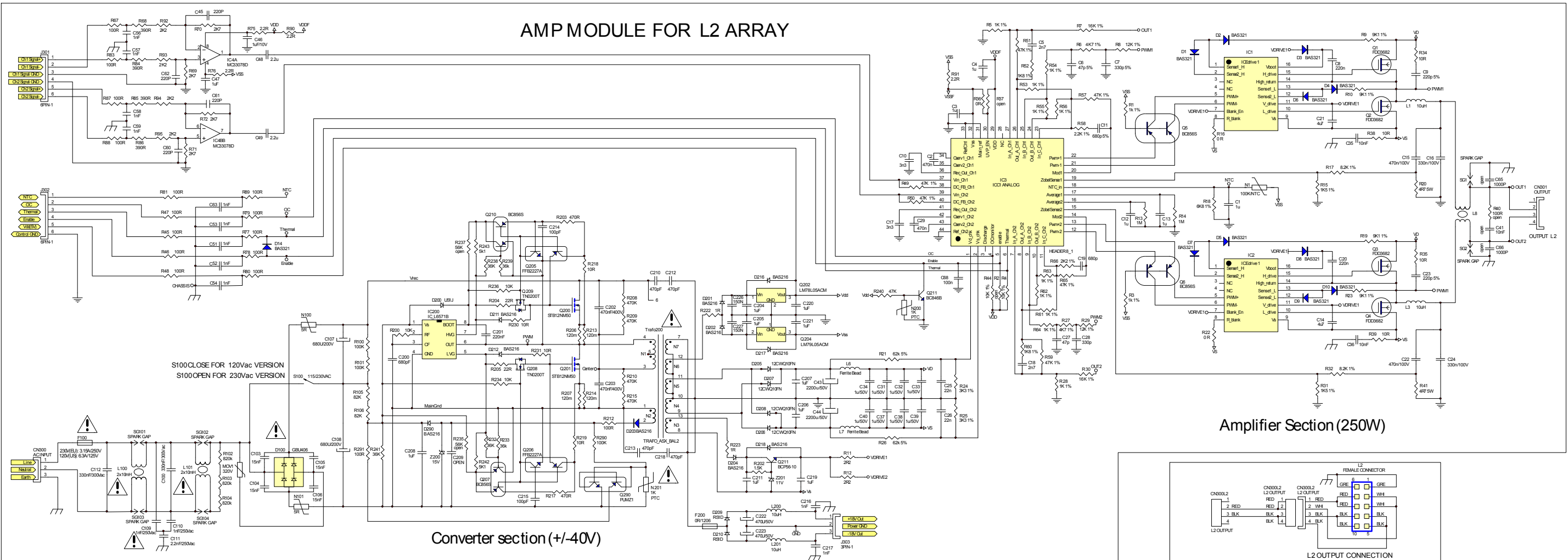

# AMP MODULE FOR B2 BASS MODULE

