

REMARK:

Project	minicon2 HIZ	minicon2 LOZ
R347	330k	68k

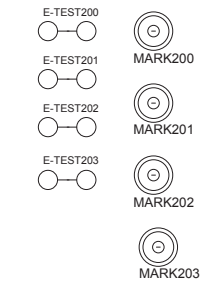

- Notes:
- 1) NC: means the part is no connect
  - 2) \*\*: Please refer to the remark
  - 3) Unless otherwise marked, all resistors are 1/16W, 0603
  - 4) Unless otherwise marked, all capacitors voltage are 50V



IZA 2120-HZ AMPLIFIER  
 SMPS PCB ASSEMBLY  
 PCB P/N: 729409-001S  
 SCHEMATIC REVISION 3.0  
 SHEET 1 OF 7

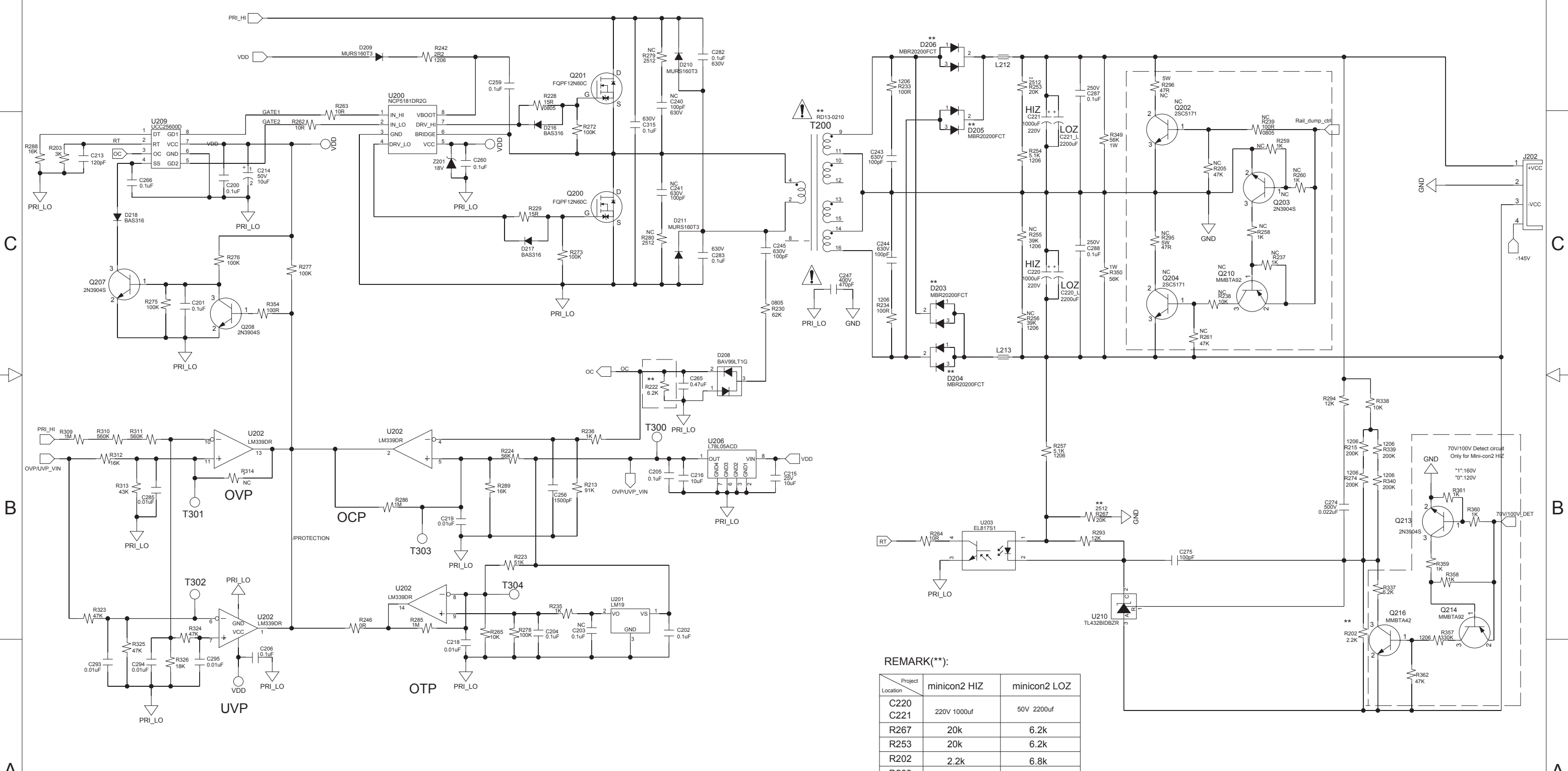

REMARK(\*\*):

Project Location	minicon2 HIZ	minicon2 LOZ
C220	220V 1000uf	50V 2200uf
R267	20k	6.2k
R253	20k	6.2k
R202	2.2k	6.8k
D203	ER1606CT	MBR20200FCT
D204	600V 16A	200V 20A
D205		
D206		
T200	O/P is 160V	O/P is 40V
R222	6.2k	4.7k

**BOSE**

IZA 2120-HZ AMPLIFIER  
 SMPS PCB ASSEMBLY  
 PCB P/N: 729409-001S  
 SCHEMATIC REVISION 3.0  
 SHEET 2 OF 7



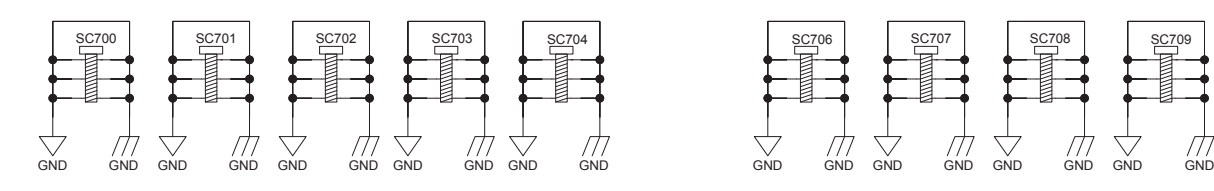
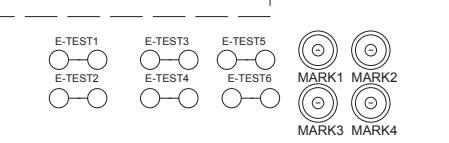
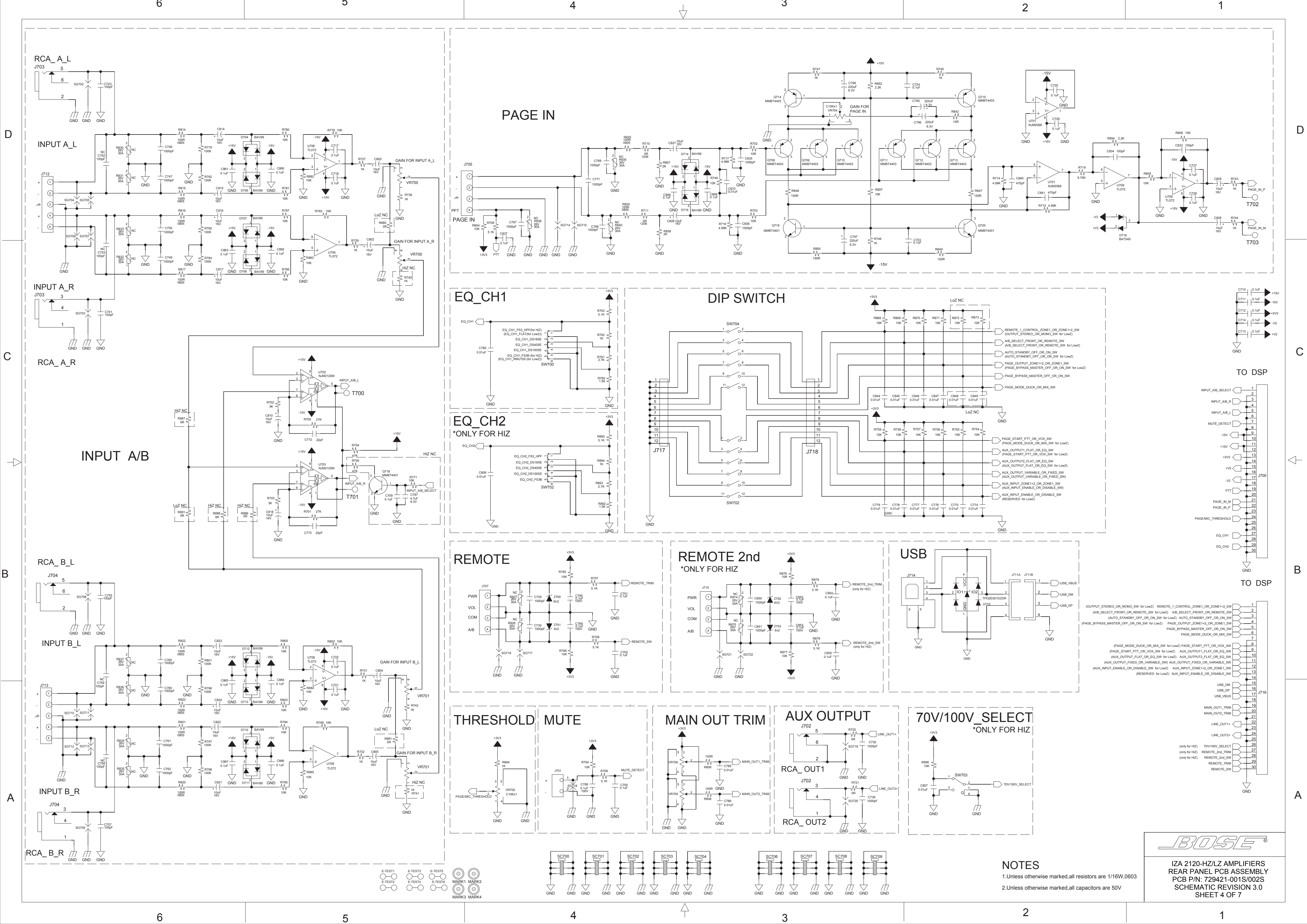

**NOTES**

- Unless otherwise marked, all resistors are 1/16W, 0603
- Unless otherwise marked, all capacitors are 50V



IZA 2120-HZ/LZ AMPLIFIERS  
 REAR PANEL PCB ASSEMBLY  
 PCB P/N: 729421-001S/002S  
 SCHEMATIC REVISION 3.0  
 SHEET 4 OF 7



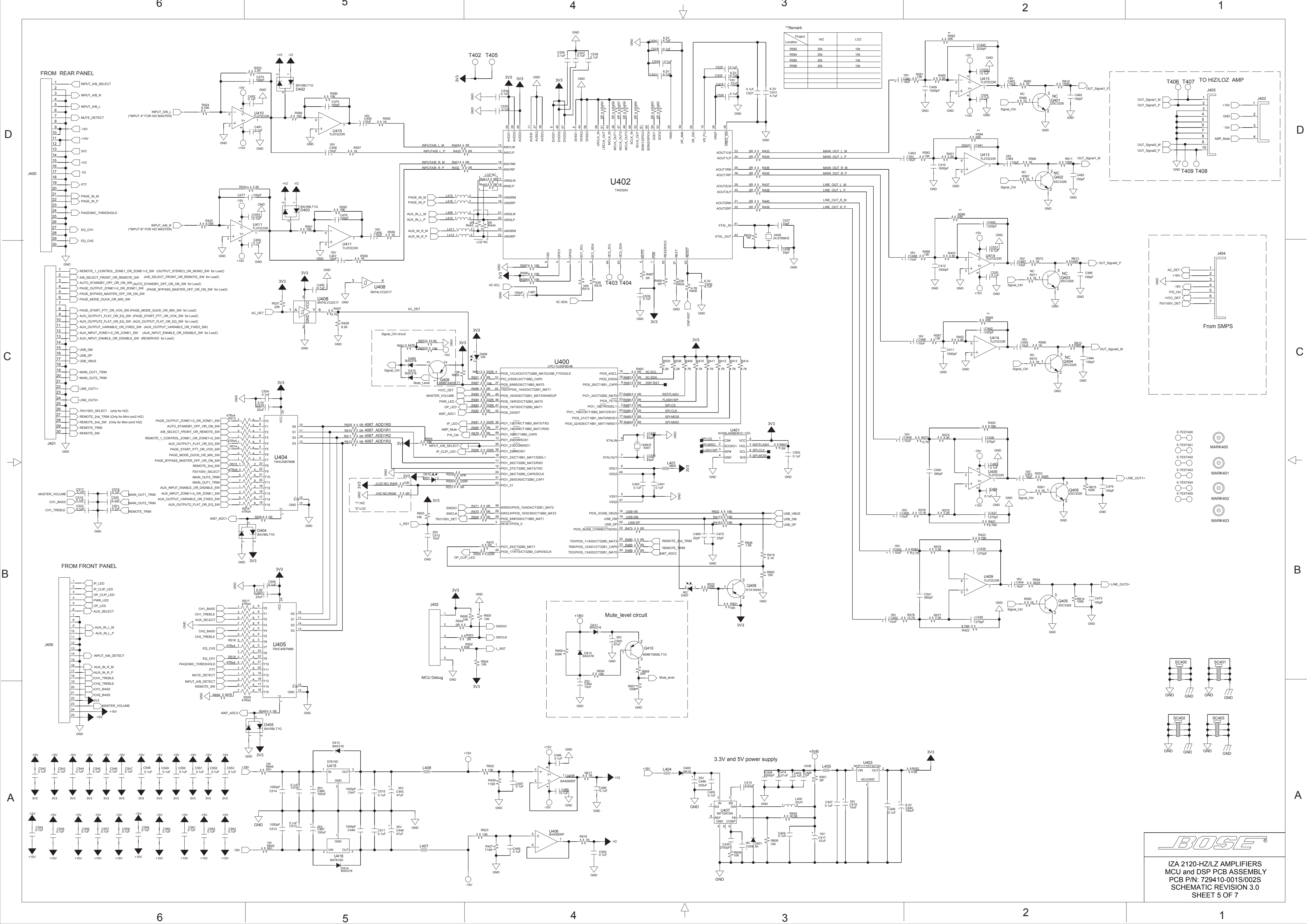

\*\*Remark

Project	HZ	LOZ
R562	20k	10k
R564	20k	10k
R565	20k	10k
R566	20k	10k

**BOSE**

IZA 2120-HZ/LZ AMPLIFIERS  
 MCU and DSP PCB ASSEMBLY  
 PCB P/N: 729410-001S/002S  
 SCHEMATIC REVISION 3.0  
 SHEET 5 OF 7

D

D

C

C

B

B

A

A

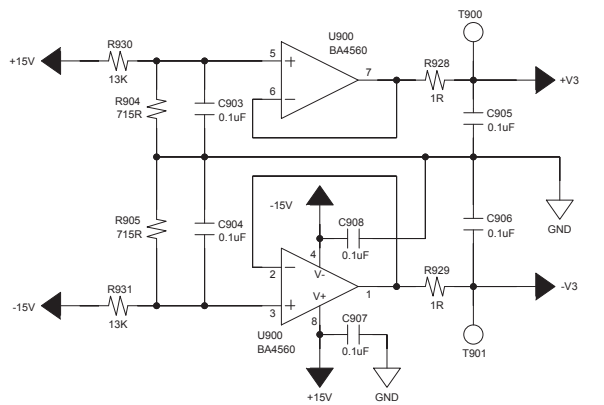
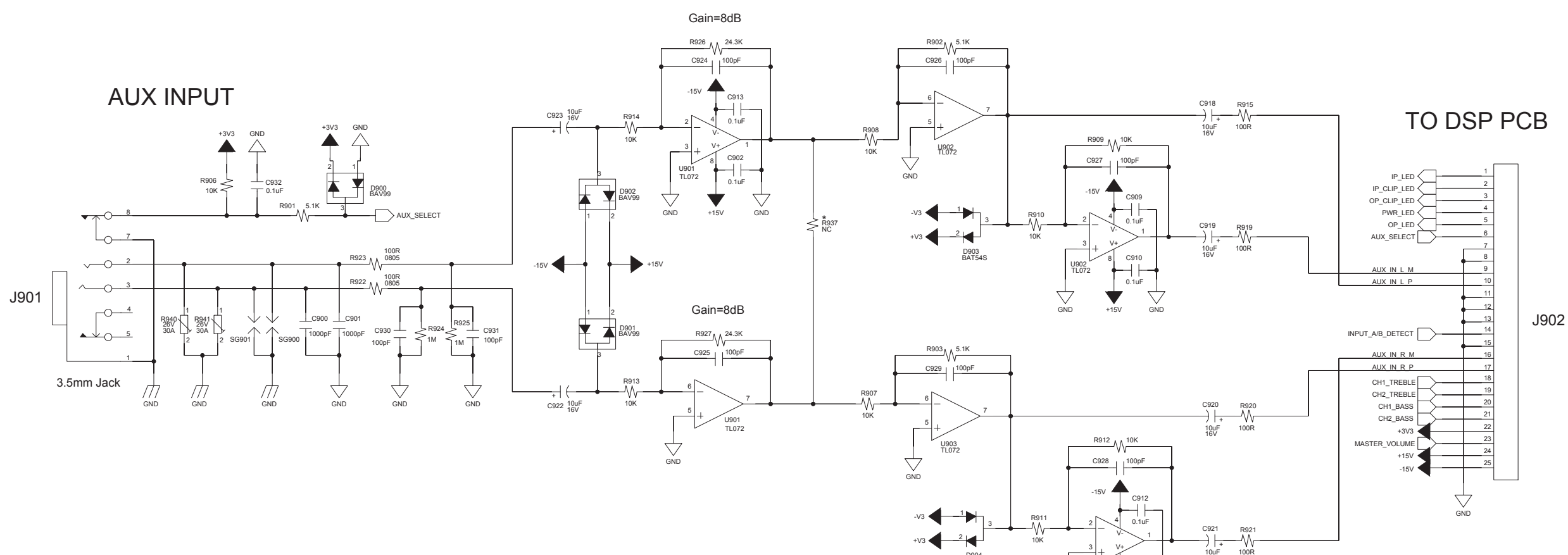

**SOURCE SELECT**

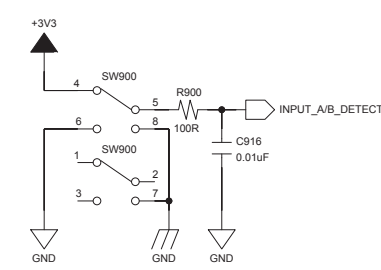

**CH1 EQ**

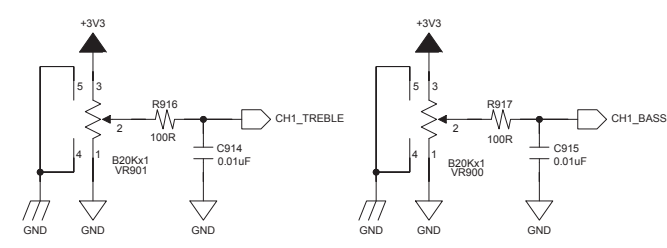

**TO FRONT LED PCB**

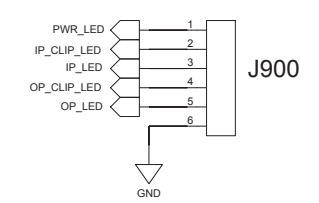

**MASTER VOLUME**

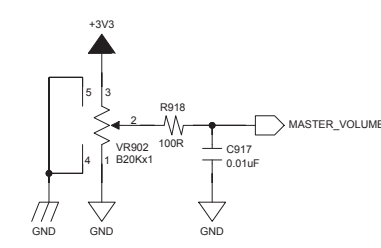

**CH2 EQ (HZ Only)**

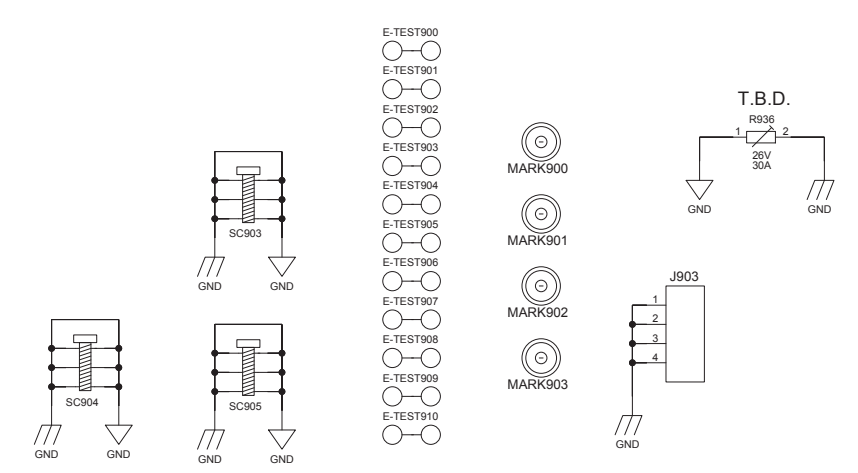
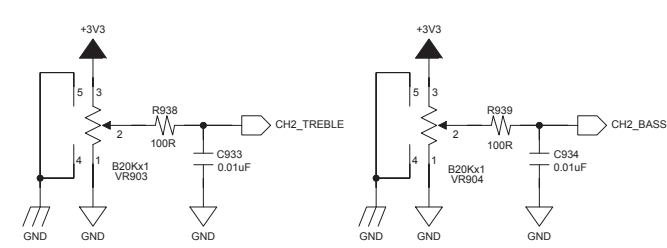

**IZA 2120-HZ/LZ AMPLIFIERS  
FRONT PANEL PCB ASSEMBLY  
PCB P/N: 729601-001S/002S  
SCHEMATIC REVISION 3.0  
SHEET 6 OF 7**

6

5

4

3

2

1

D

D

C

C

B

B

A

A

### FRONT LED

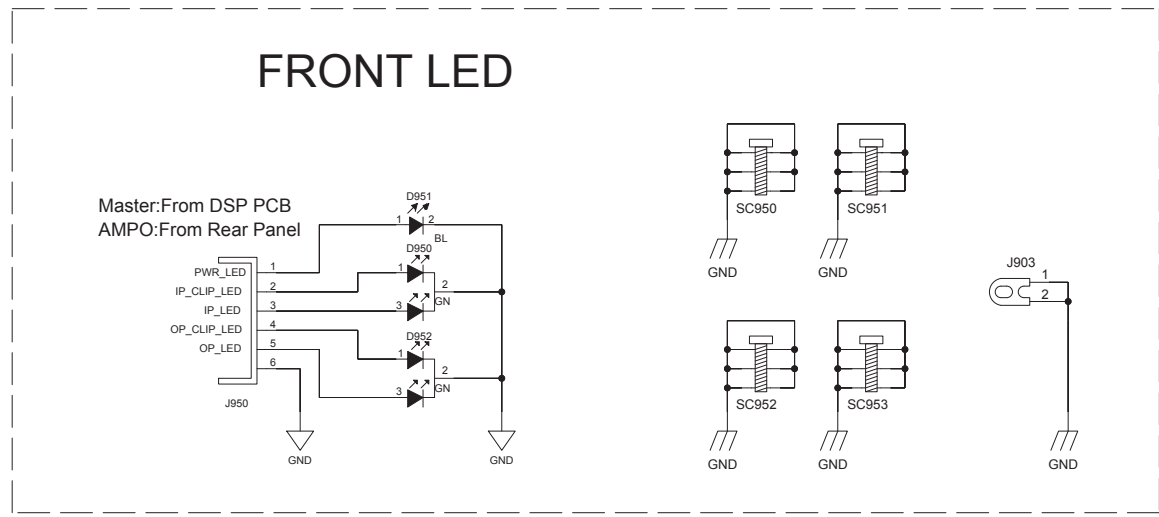

### SPEAKER OUTPUT

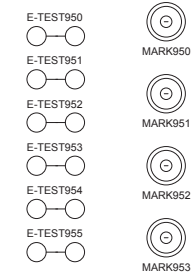
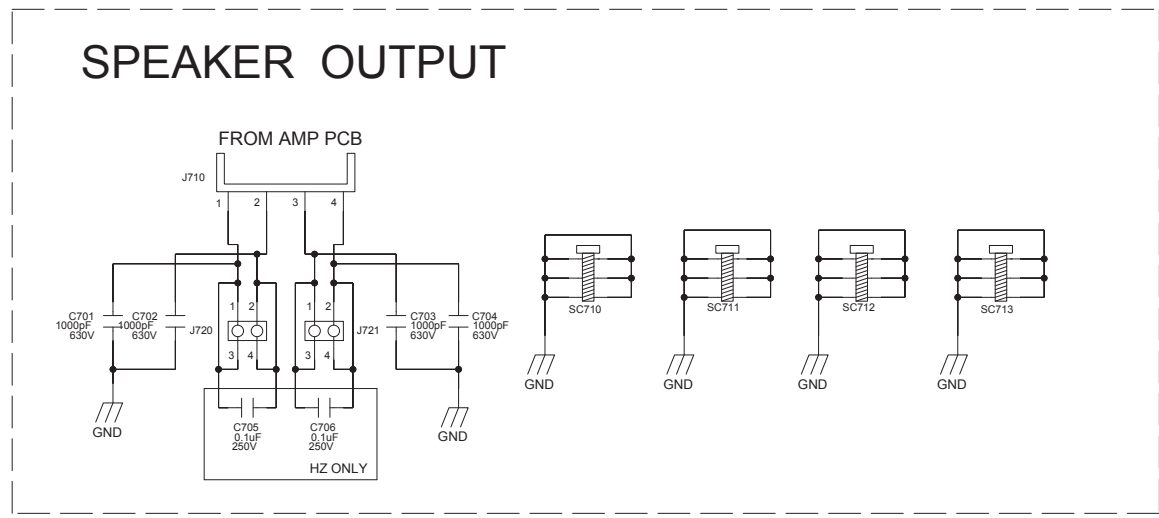

IZA 2120-HZ/LZ AMPLIFIERS  
FRONT LED PCB ASSEMBLY  
PCB P/N: 729412-001S  
SPEAKER OUTPUT PCB ASSEMBLY  
PCB P/N: 729597-001S  
SCHEMATIC REVISION 3.0  
SHEET 7 OF 7

6

5

4

3

2

1