

REMARK:

Project	minicon2 HIZ	minicon2 LOZ
R347	330k	68k

- E-TEST200
 - E-TEST201
 - E-TEST202
 - E-TEST203
- MARK200
MARK201
MARK202
MARK203

- Notes:
- 1)NC:means the part is no connect
 - 2)**:Please refer to the remark
 - 3)Unless otherwise marked,all resistor is 1/16W,0603
 - 4)Unless otherwise marked,all capacitors voltage is 50V

BOSE

IZA 2120-LZ AMPLIFIER
SMPS PCB ASSEMBLY
PCB P/N: 729409-002S
SCHEMATIC REVISION 3.0
SHEET 1 OF 7

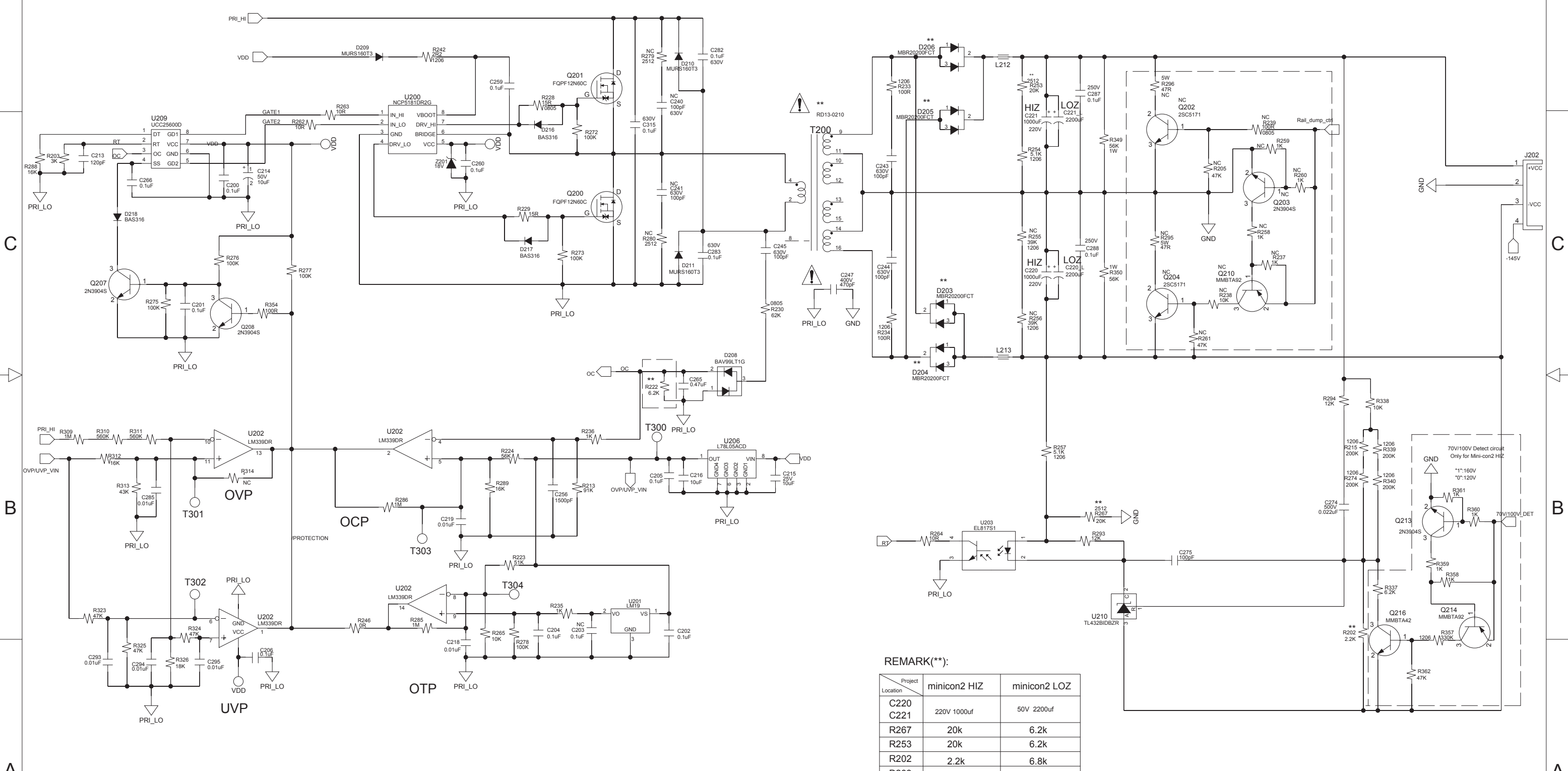

REMARK(**):

Project Location	minicon2 HIZ	minicon2 LOZ
C220	220V 1000uf	50V 2200uf
C221	220V 1000uf	50V 2200uf
R267	20k	6.2k
R253	20k	6.2k
R202	2.2k	6.8k
D203	ER1606CT	MBR20200FCT
D204	600V 16A	200V 20A
D205		
D206		
T200	O/P is 160V	O/P is 40V
R222	6.2k	4.7k

BOSE[®]

IZA 2120-LZ AMPLIFIER
SMPS PCB ASSEMBLY
PCB P/N: 729409-002S
SCHEMATIC REVISION 3.0
SHEET 2 OF 7

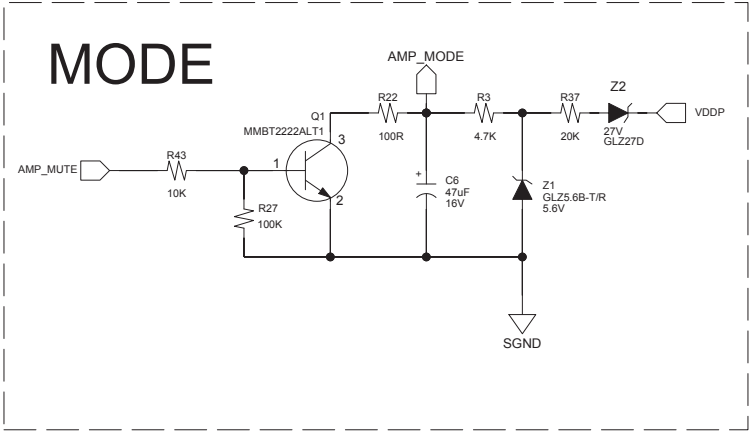
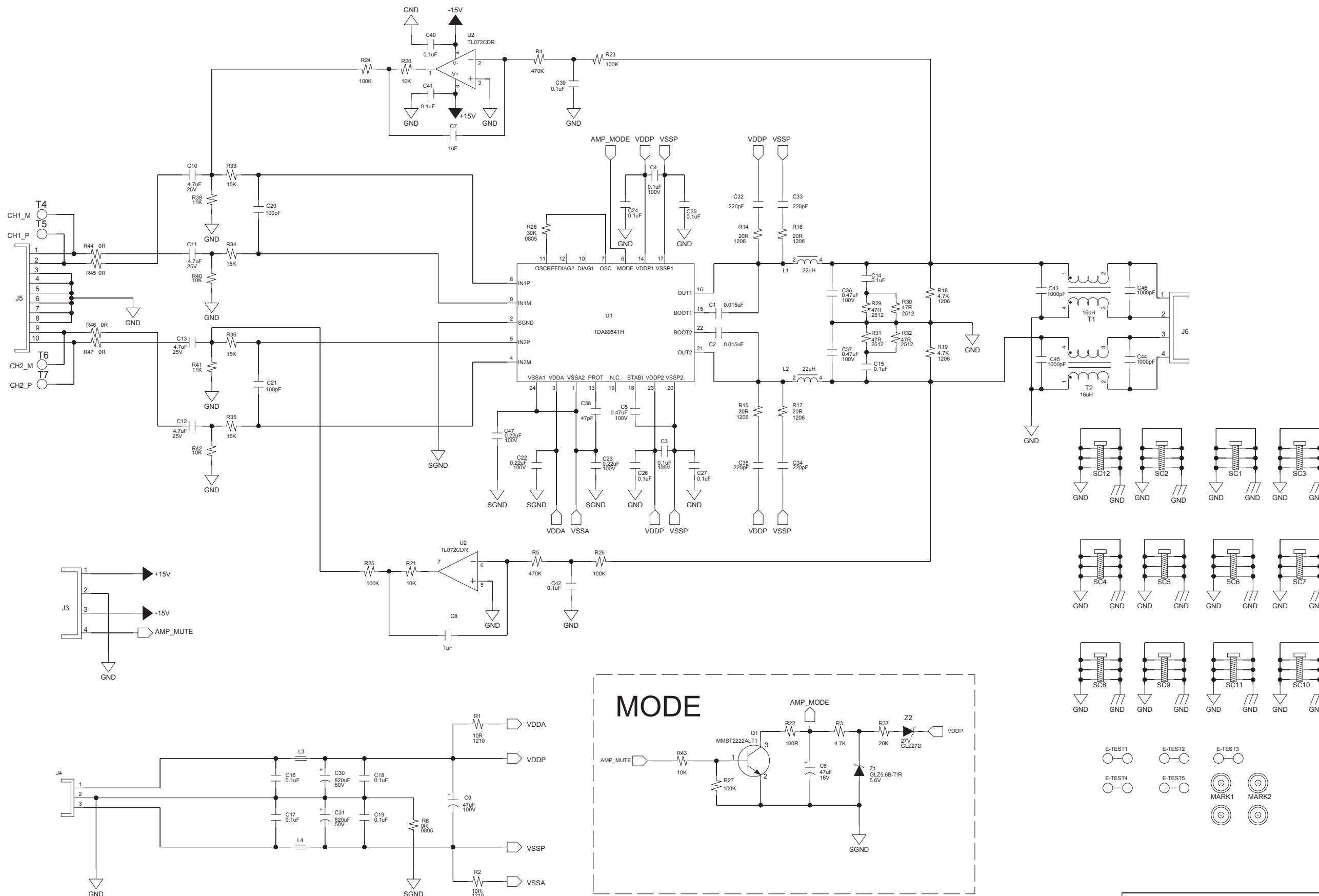

NOTES

1. Unless otherwise marked, all resistors are 1/16W, 0603
2. Unless otherwise marked, all capacitors are 50V

BOSE

IZA 2120-LZ AMPLIFIER
AMPLIFIER PCB ASSEMBLY
PCB P/N: 740163-001S
SCHEMATIC REVISION 3.0
SHEET 3 OF 7

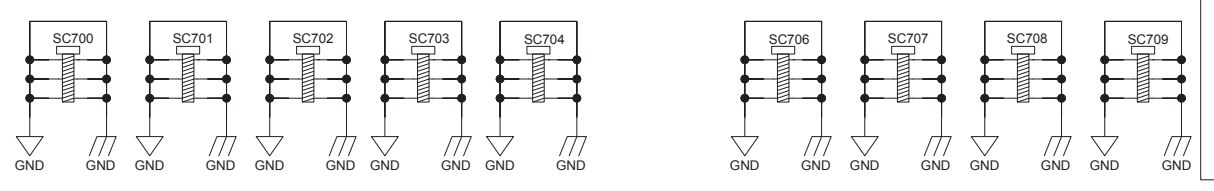
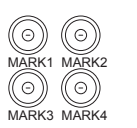
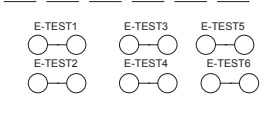
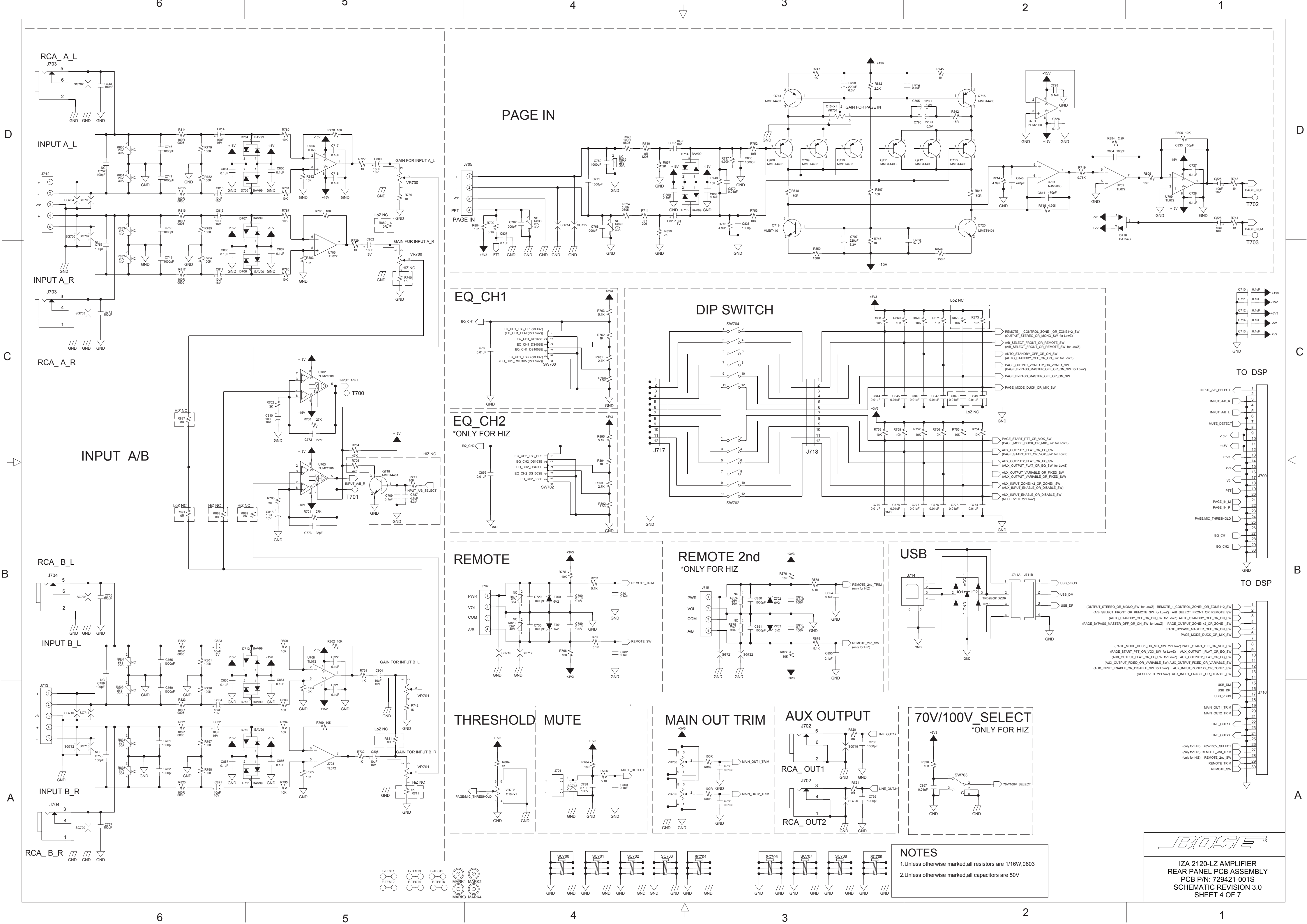

NOTES
1. Unless otherwise marked, all resistors are 1/16W, 0603
2. Unless otherwise marked, all capacitors are 50V

BOSE
IZA 2120-LZ AMPLIFIER
REAR PANEL PCB ASSEMBLY
PCB P/N: 729421-001S
SCHEMATIC REVISION 3.0
SHEET 4 OF 7

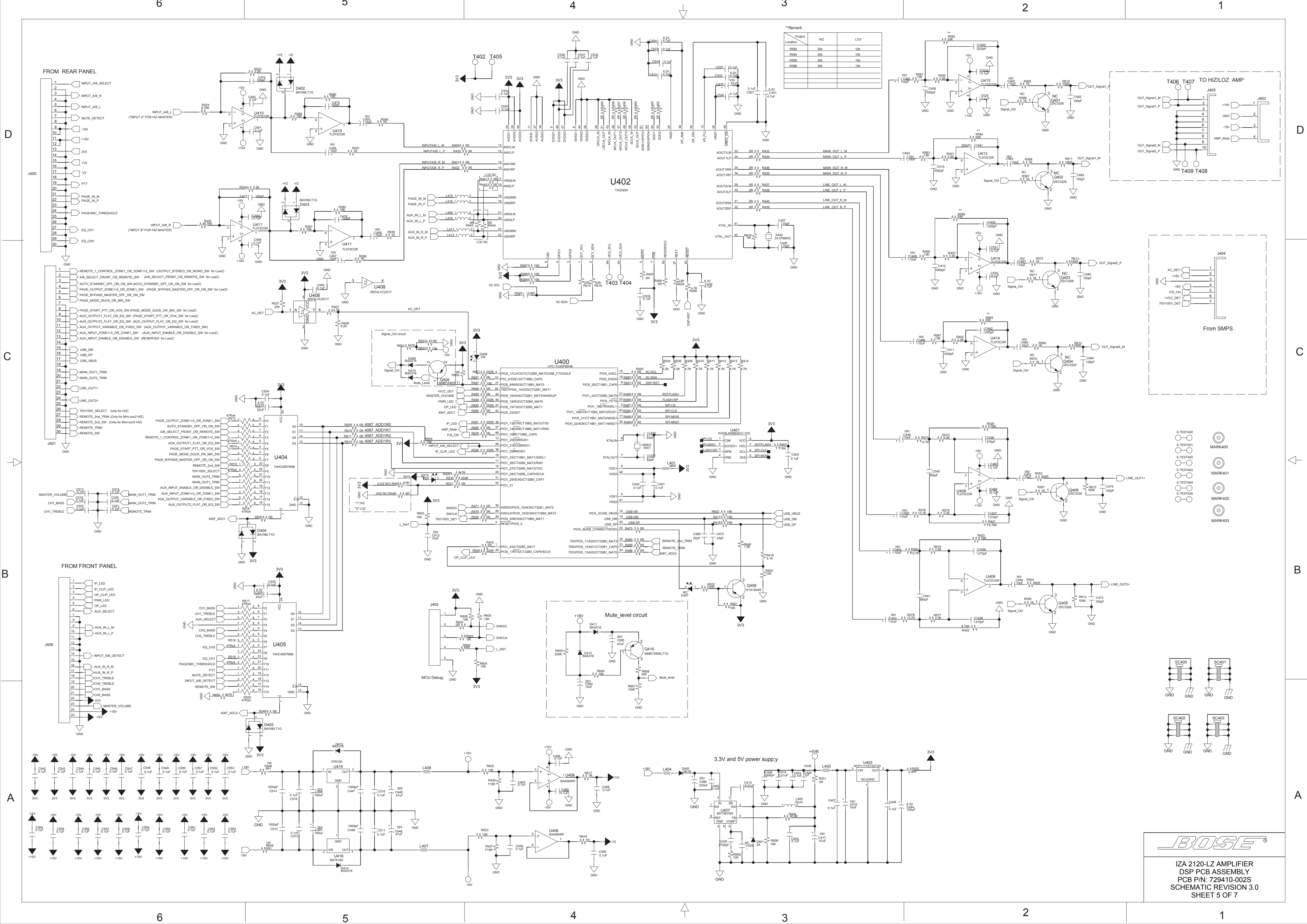

IZA 2120-LZ AMPLIFIER
DSP PCB ASSEMBLY
PCB P/N: 729410-002S
SCHEMATIC REVISION 3.0
SHEET 5 OF 7

D

D

C

C

B

B

A

A

AUX INPUT

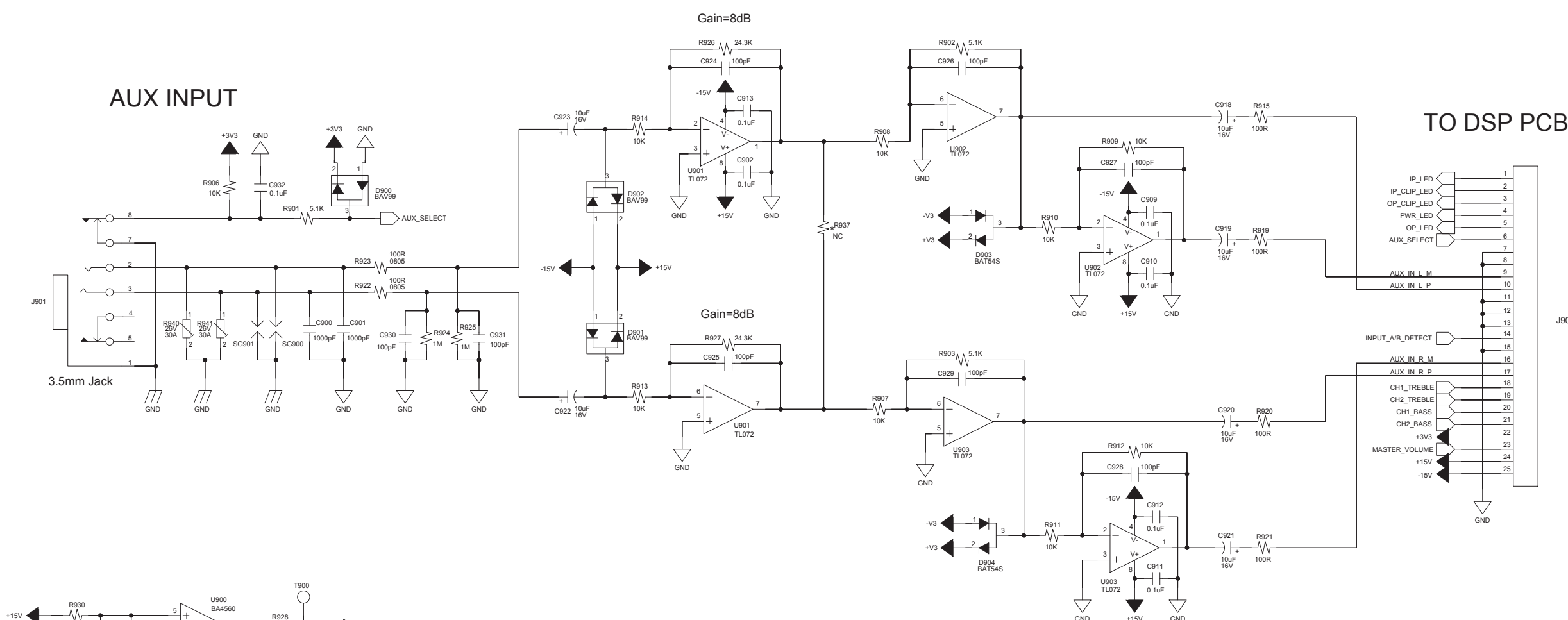

TO DSP PCB

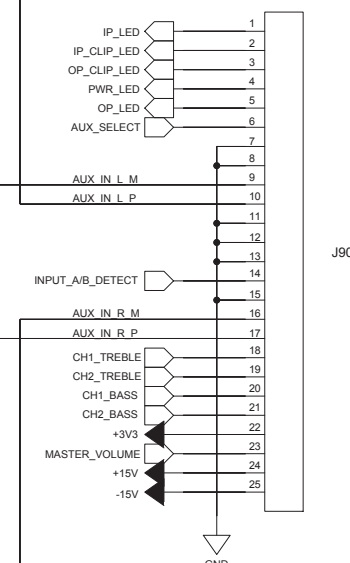

TO FRONT LED PCB

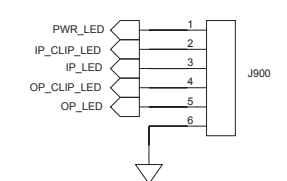

SOURCE SELECT

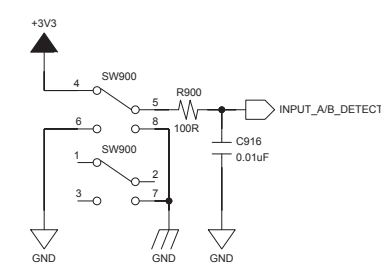

CH1 EQ

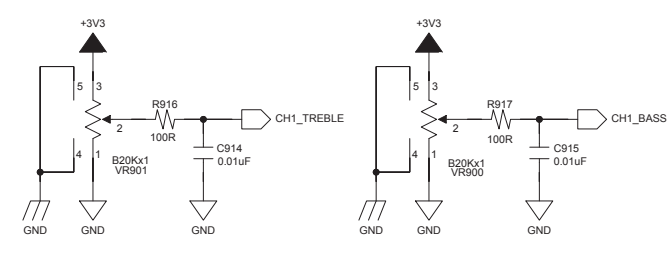

MASTER VOLUME

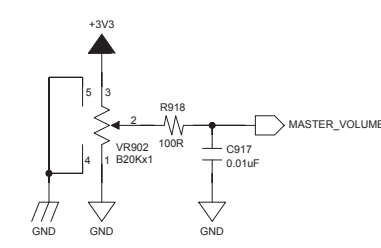

CH2 EQ (HZ Only)

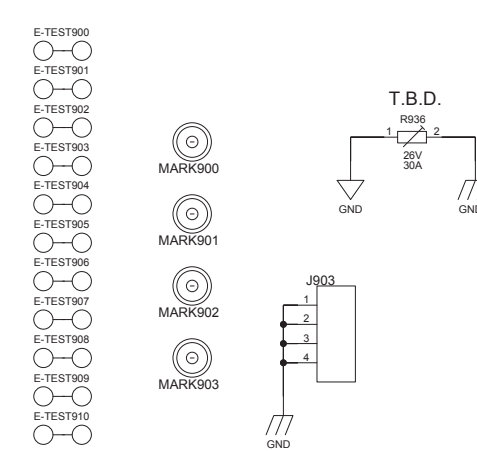
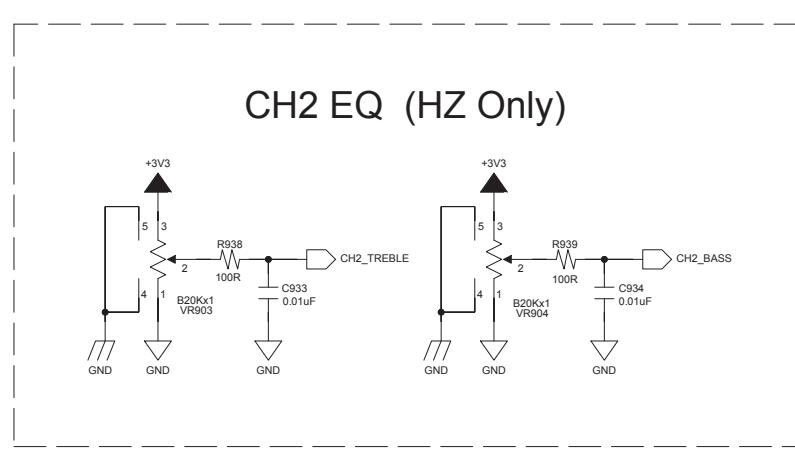

IZA 2120-LZ AMPLIFIER
 FRONT PANEL PCB ASSEMBLY
 PCB P/N: 729601-002S
 SCHEMATIC REVISION 3.0
 SHEET 6 OF 7

6

5

4

3

2

1

D

D

C

C

B

B

A

A

FRONT LED

Master: From DSP PCB
AMPO: From Rear Panel

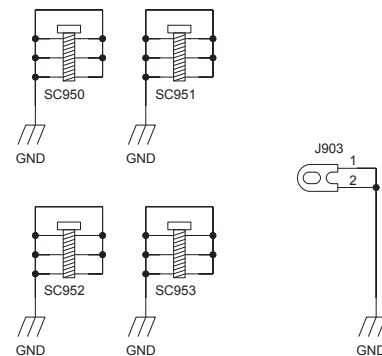
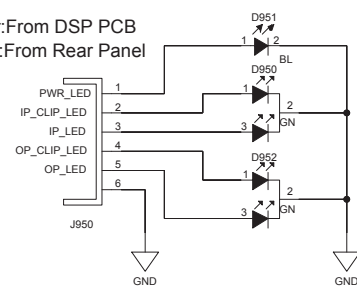

SPEAKER OUTPUT

FROM AMP PCB

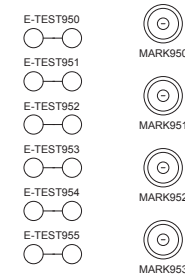
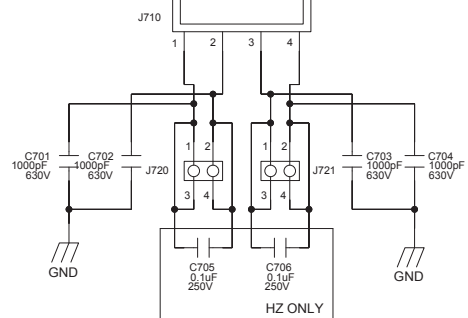

IZA 2120-HZ/LZ AMPLIFIERS
 FRONT LED PCB ASSEMBLY
 PCB P/N: 729412-001S
 SPEAKER OUTPUT PCB ASSEMBLY
 PCB P/N: 729597-001S
 SCHEMATIC REVISION 3.0
 SHEET 7 OF 7

6

5

4

3

2

1