

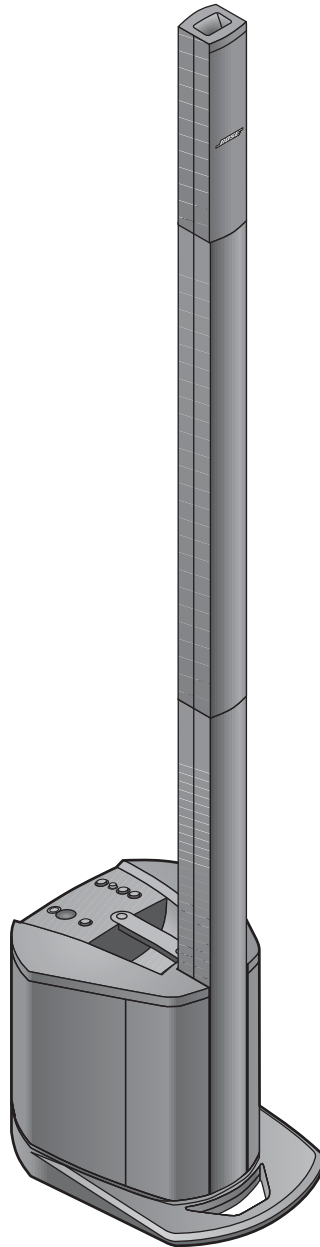

L1[®] Compact Portable Line Array System



Contents

Safety Information	3
Warranty	3
Specifications	4
Electrostatic Discharge Sensitive (ESDS) Device Handling	5
Part List Notes	5
L1 Compact Accessory Pack	5
Product Description	6-8
Packaging Part List, L1 Compact Power Stand (includes Array) (see Figure 1)	9
Figure 1. L1 Compact Power Stand Packaging View	9
Packaging Part List, L1 Compact Array Extensions (see Figure 2)	10
Figure 2. L1 Compact Array Extensions Packaging View	10
Main Part List, L1 Compact Power Stand (see Figure 3)	11-12
Figure 3. L1 Compact Power Stand Exploded View	12
Main Part List, L1 Compact Array Speaker (see Figure 4)	13
Figure 4. L1 Compact Array Speaker Exploded View	13
Main Part List, L1 Compact Array Extension Exploded View (see Figure 5)	14
Figure 5. L1 Compact Array Extension Exploded View	14
Electrical Part List	15-37
Input/Output PCB Assembly	15-29
3.5mm Line Input PCB Assembly	29
Output PCB Assembly	29-30
Power Amplifier PCB Assembly	31-37
Disassembly Procedures	38-44
Test Procedures	45-48
IC Diagrams	49-50
Service Manual Revision History	51

Safety Information

1. Parts that have special safety characteristics are identified by the  symbol on schematics or by special notes on the parts list. Use only replacement parts that have critical characteristics recommended by the manufacturer.

2. Make leakage current or resistance measurements to determine that exposed parts are acceptably insulated from the supply circuit before returning the unit to the customer. Use the following checks to perform these measurements:

A. Leakage Current Hot Check-With the unit completely reassembled, plug the AC line cord directly into a 120V AC outlet. (Do not use an isolation transformer during this test.) Use a leakage current tester or a metering system that complies with American National Standards Institute (ANSI) C101.1 "Leakage Current for Appliances" and Underwriters Laboratories (UL) 6500 / IEC 60056 paragraph 9.1.1. With the unit AC switch first in the ON position and then in OFF position, measure from a known earth ground (metal waterpipe, conduit, etc.) to all exposed metal parts of the unit (antennas, handle bracket, metal cabinet, screwheads, metallic overlays, control shafts, etc.), especially any exposed metal parts that offer an electrical return path to the chassis. Any current measured must not exceed 0.5 milliamp. Reverse the unit power cord plug in the outlet and repeat test. **ANY MEASUREMENTS NOT WITHIN THE LIMITS SPECIFIED HEREIN INDICATE A POTENTIAL SHOCK HAZARD THAT MUST BE ELIMINATED BEFORE RETURNING THE UNIT TO THE CUSTOMER.**

B. Insulation Resistance Test Cold Check-(1) Unplug the power supply and connect a jumper wire between the two prongs of the plug. (2) Turn on the power switch of the unit. (3) Measure the resistance with an ohmmeter between the jumpered AC plug and each exposed metallic cabinet part on the unit. When testing 3 wire products, the resistance measured to the product enclosure should be between 2 and infinite MOhms. Also, the resistance measured to exposed input/output connectors should be between 4 and infinite MOhms. When testing 2 wire products, the resistance measured to exposed input/output connectors should be between 4 and infinite MOhms. If it is not within the limits specified, there is the possibility of a shock hazard, and the unit must be repaired and rechecked before it is returned to the customer.

CAUTION: The Bose® L1® Compact system contains no user-serviceable parts. To prevent warranty infractions, refer servicing to warranty service stations or factory service.

PROPRIETARY INFORMATION

THIS DOCUMENT CONTAINS PROPRIETARY INFORMATION OF BOSE CORPORATION WHICH IS BEING FURNISHED ONLY FOR THE PURPOSE OF SERVICING THE IDENTIFIED BOSE PRODUCT BY AN AUTHORIZED BOSE SERVICE CENTER OR OWNER OF THE BOSE PRODUCT, AND SHALL NOT BE REPRODUCED OR USED FOR ANY OTHER PURPOSE.

Warranty

The Bose L1 Compact Power Stand is covered by a limited 2-year transferable warranty. The L1 Compact Array and the Power Stand woofer are covered by a 5-year limited warranty.

Specifications

Mechanical

Part	Dimensions	Weight
L1 Compact Power Stand with Loudspeaker Array	16.5" H x 13.25" W x 16.75" D (41.8 cm x 33.9 cm x 42.6 cm)	24.6 lbs (11.2 kg)
L1 Compact Loudspeaker Array	16" H x 2.75" W x 2.75" D (40.8 cm x 7 cm x 7.1 cm)	3.0 lbs (1.35 kg)
L1 Compact Extensions (2)	32.5" H x 2.75" W x 2.75" D	2.3 lbs (1.05 kg) each
Collapsed Position (assembled)	16.5" H x 13.25" W x 16.75" D (41.8 cm x 33.9 cm x 42.6 cm)	24.6 lbs (11.2 kg)
Extended Position (assembled)	78.5" H x 13.25" W x 16.75" D (199.5 cm x 33.9 cm x 42.6 cm)	29.2 lbs (13.3 kg)

Shipping Cartons

	Weight
L1 Compact System (no extensions)	30.4 lbs (13.8 kg)
L1 Compact Extensions	7.5 lbs (3.4 kg)

Electrical

AC Power Rating

100 - 240 VAC ~ 50/60 Hz, 200W max

Peak Inrush Current

230V: 18.2 Amps

120V: 9.7 Amps

Electrostatic Discharge Sensitive (ESDS) Device Handling

This unit contains ESDS devices. We recommend the following precautions when repairing, replacing or transporting ESDS devices:

- Perform work at an electrically grounded work station.
- Wear wrist straps that connect to the station or heel straps that connect to conductive floor mats.
- Avoid touching the leads or contacts of ESDS devices or PC boards even if properly grounded. Handle boards by the edges only.
- Transport or store ESDS devices in ESD protective bags, bins, or totes. Do not insert unprotected devices into materials such as plastic, polystyrene foam, clear plastic bags, bubble wrap or plastic trays.

Part List Notes

1. This part is not normally available from Customer Service. Approval from the Field Service Manager is required before ordering.
2. The individual parts located on the PCBs are listed in the Electrical Part List.
3.  This part is critical for safety purposes. Failure to use a substitute replacement with the same safety characteristics as the recommended replacement part might create shock, fire and/or other hazards.
4. This part is referenced for informational purposes only. It is not stocked as a repair part. Refer to the next higher assembly for a replacement part.

L1 Compact Accessory Pack

Description	Bose® Part Number	Vendor Part Number
L1 Microphone Accessory Pack, Includes all items below	322711-0000	-
Audix OM3 Cardioid Dynamic Vocal Microphone	318884-0000	OM3
20' XLR Microphone Cable	318885-0000	CBL-20
Carton, L1 Microphone Accessory Pack, RSC, 10.50x8.50x5.75"	318886-0000	N/A
Cable, Audio, Dual, RCA	185931-01	N/A
Cable, Input, 3.5mm, 6ft, Black	271994-001	N/A

L1 Compact System Versions

Description	Bose® Part Number
L1 Compact Power Stand, 120V (US)	318882-1100
L1 Compact Power Stand, 220V (China)	318882-2100
L1 Compact Power Stand, 100V (Japan)	318882-3100
L1 Compact Power Stand, 230V (Euro)	318882-4100
L1 Compact Power Stand, 240V (UK)	318882-5100

Product Description

Whether you are a musician amplifying your instruments, a mobile DJ entertaining an audience, or the host of your own special event, the Bose® L1® Compact Portable Line Array System will provide quality sound for audiences of approximately 100 people.

Features Include

- Carry it in one trip – The entire system is light enough to be carried in a single trip.
- Set it up in one minute – The interlocking components of the L1 Compact system allow system setup in less than a minute. There are no external speaker wires required. An integrated bass enclosure with an intuitive user interface eliminates the need for separate components.
- Fill the room with one loudspeaker – Whether you're performing live or playing back prerecorded music, whether you're performing in a coffeehouse or a 100-seat room, Bose Spatial Dispersion™ loudspeaker technology provides nearly 180° of tonally balanced sound coverage so there are no dead spots.
- PA and monitor combined – Audience members enjoy a more consistent and intimate listening experience because the system sets up behind the performer and serves as both the monitor for the stage and amplification system for the audience. The performer alone controls the sound.
- Versatility – In addition to musical performances, the L1 Compact provides quality sound for a wide variety of general-purpose uses including presentations, celebrations, speeches, and music playback for about 100 people.
- Integrated ToneMatch® signal processing – Provides a high level of tone customization on your microphone or acoustic guitar to provide a listening experience that most musicians only achieve using a recording studio.
- Two setup options – The L1 Compact system can be used in either the collapsed position for smaller audiences or extended positions for larger audiences.

The L1 Compact Portable Line Array System is shipped in two cartons.

The L1 Compact system consists of:

- L1 Compact Power Stand
- L1 Compact Loudspeaker Array
- L1 Compact Extensions

The L1 Compact system comes with a slipcover for the Power Stand and a padded carry bag for the L1 Compact Extensions.

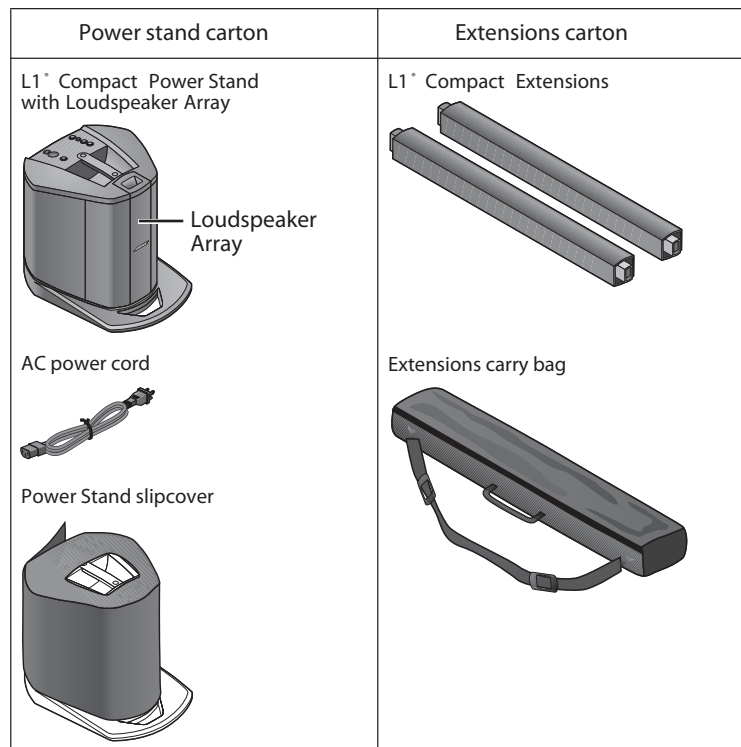

Product Description

System configurations

You can set up the L1® Compact system in two unique positions. The examples below will help you quickly identify the position that can work best for you.

The L1 Compact Extensions are not required when using the L1 Compact Portable Line Array System in the collapsed position. They are included for situations where you need to elevate the Loudspeaker Array to project sound to larger audiences.

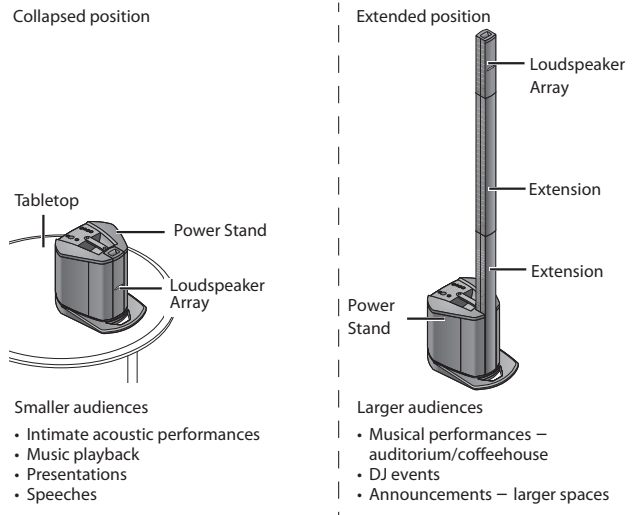

Extending the Loudspeaker Array

Once you have set the system in place:

1. Slide the Loudspeaker Array up and out of the Power Stand and temporarily lay it aside.

Note: The two L1 Compact Extensions are identical to each other.

2. Align the plug on the bottom of the Extension with the socket on the Power Stand, then slide the extension into the power stand.

3. Align the remaining Extension and push it firmly in place.

4. Align the Loudspeaker Array and push it firmly in place.

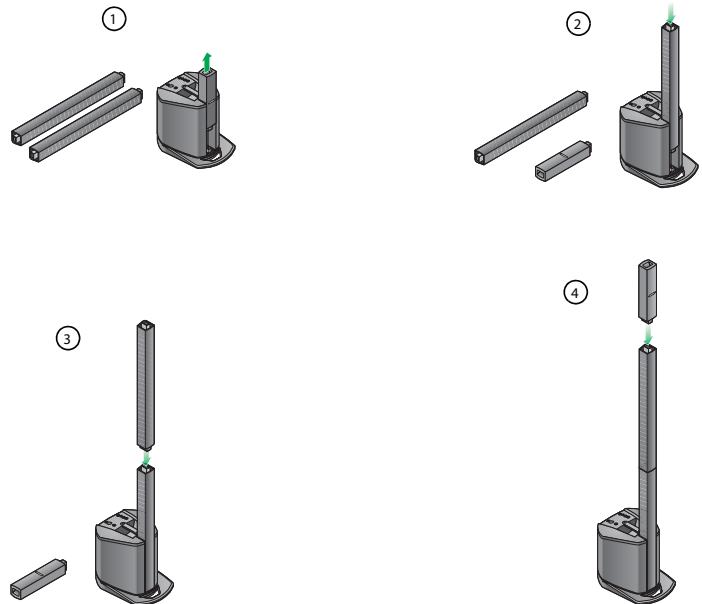

Connecting power to the system

1. Make sure the power switch is off (down position).

2. Plug one end of the power cord into the connector on the power stand.

3. Plug the other end into a live electrical receptacle.

4. Before turning the system on, connect your sound sources.



Product Description

Connections and controls

The power stand control panel provides all the necessary connectors, controls, and indicators for operation.

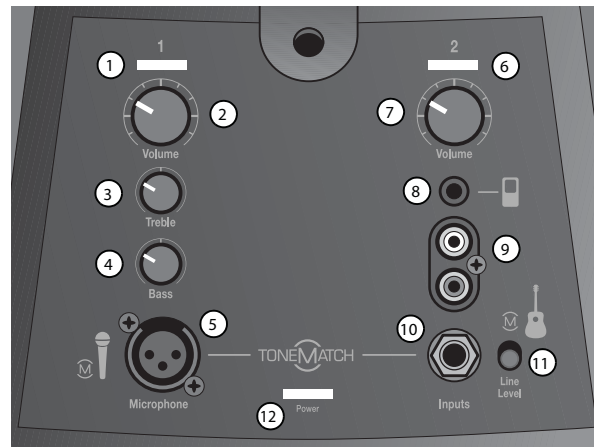

Channel 1 (Microphone input)

The channel 1 input is for use only with a microphone. Integrated ToneMatch[®] signal processing provides a high level of tone customization to provide a listening experience that most musicians can only achieve using a recording studio.

1. Signal/Clip indicator – Displays the input signal status in color.

- Green: Input signal present
- Red: Input signal clipping

2. Volume control – Adjusts the volume of your microphone.

3. Treble control – Adjusts the amount of treble on your microphone.

4. Bass control – Adjusts the amount bass on your microphone.

5. Microphone input – Analog input for connecting a balanced XLR microphone cable. A ToneMatch microphone preset is built in.

Channel 2 (Utility channel – multiple input)

6. Signal/Clip indicator – Displays the input signal status in color.

- Green: Input signal present
- Red: Input signal clipping

7. Volume control – Adjusts the overall volume of all input sources connected to Channel 2.

8. 1/8-inch stereo input – Stereo analog input for connecting audio sources such as portable mp3 players, satellite radio, laptop computers, video projectors, and smart boards. Left and right inputs are summed by the power stand.

9. RCA stereo input – Analog input for connecting audio sources such as DVD players, VCR players, video game consoles, DJ mixers, Keyboards and other instruments. For best results, connect both the left and right signals. Left and right inputs are summed by the power stand.

10. 1/4-inch input – Balanced analog input for connecting guitars and other instruments. Accepts either 1/4-inch TRS balanced or TS unbalanced cables.

11. ToneMatch switch – When connecting an acoustic guitar to the 1/4-inch input, move the switch to the position to enable a ToneMatch preset. When connecting anything other than an acoustic guitar to the 1/4-inch input, move the switch down to the Line Level position.

12. Power LED – Indicates power status.
Blue: Power on

Packaging Part List

L1 Compact Power Stand (includes Array) (see Figure 1)

Item Number	Description	Bose® Part Number	Vendor Part Number	Note
1	Inner Sheet, Cardboard	324116-001S	1451-0340+0	
2	Power Cord, 120V, (US)	298165	7012-7340+0	3 
	Power Cord, 220V (China)	318882-210S	7013-0580+0	
	Power Cord, 100V, (Japan)	298167	7012-5530+0	
	Power Cord, 230V (Euro)	298166	7012-6980+0	
	Power Cord, 240V (UK)	298168	7012-6603+0	
3	Owner's Guide, 3 Lang (US/UK)	317638-0010	4301-7353+0	
	Owner's Guide (Euro)	320042-0010	4301-7354+0	
	Owner's Guide (China)	320043-0010	4301-7356+0	
	Owner's Guide (Japan)	320044-0010	4301-7352+0	
	2YR Warranty Card, Registration	320561-0010	3050-4571+0	
4	Filler, Top, Power Stand	317383-000S	1493-2001+0	
5	Quick Start Guide Card	317639-0010	3050-4561+0	
6	Power Stand Slip Cover	317403-010S	4201-1180+0	
7	L1 Compact Power Stand, 120V (US)	REF	-	
	L1 Compact Power Stand, 220V (China)	REF	-	
	L1 Compact Power Stand, 100V (Japan)	REF	-	
	L1 Compact Power Stand, 230V (Euro)	REF	-	
	L1 Compact Power Stand, 240V (UK)	REF	-	
8	Filler, Bottom, Power Stand	317384-000S	1493-2011+0	
9	Carton, Powerstand	317382-000S	1481-4801+0	
-	L1 Compact Loudspeaker Array	318880-0100	svc-cajun11+arra	
-	Warranty Card, English Language	307430	3050-3531+0	
-	Poly Bag	320228-0000	1497-4122+0	

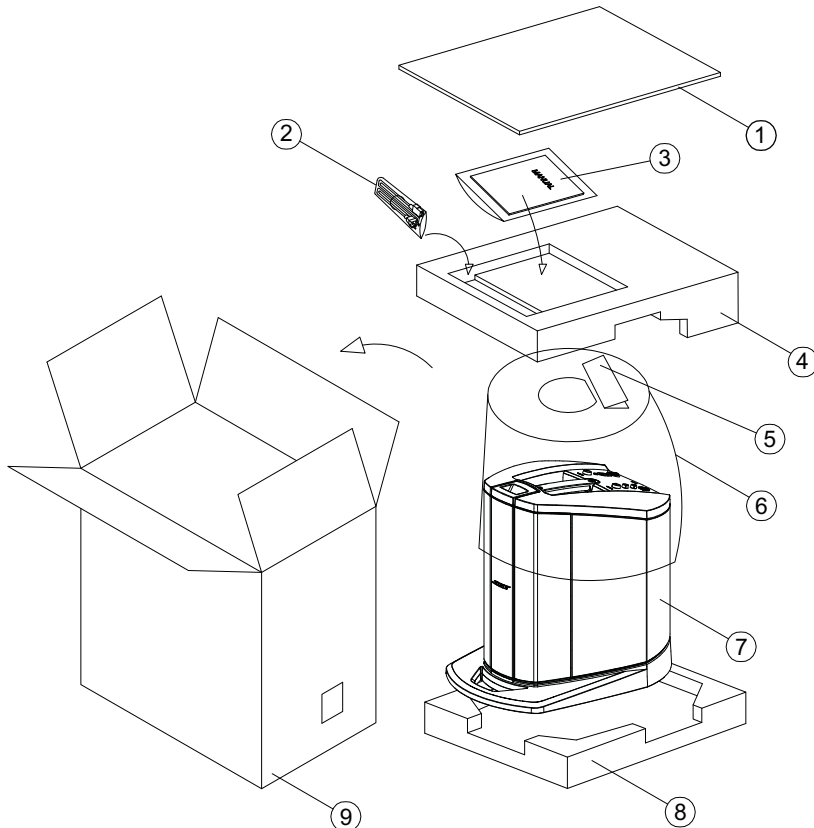

Figure 1. L1 Compact Power Stand Packaging View

Packaging Part List

L1 Compact Array Extensions (see Figure 2)

Item Number	Description	Bose® Part Number	Vendor Part Number	Note
1	Carton, Extensions	317385-000S	1481-4701+0	
2	Extensions Carry Bag	317404-010S	4201-1170+0	
3	L1 Compact Extension	318881-010S	svc-cajun11+exte	

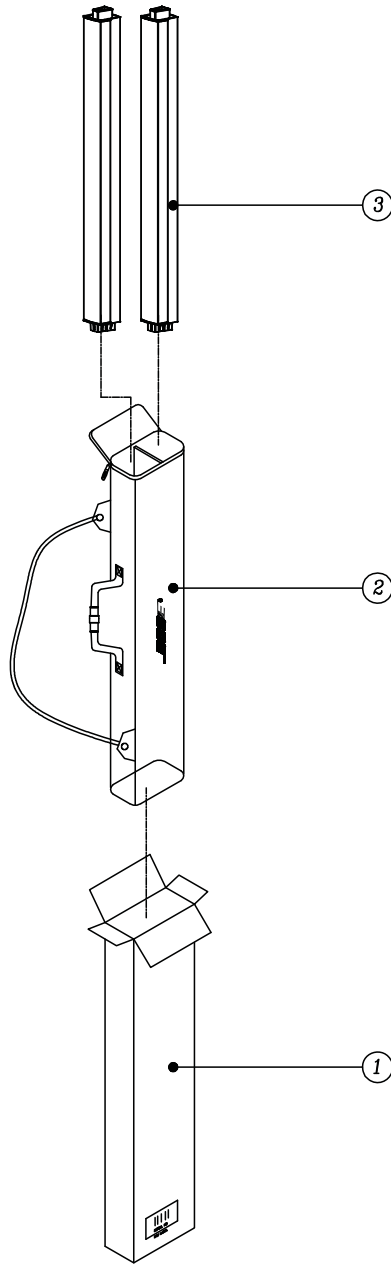









Figure 2. L1 Compact Array Extensions Packaging View

Main Part List

L1 Compact Power Stand (see Figure 3)

Item Number	Description	Bose® Part Number	Vendor Part Number	Note
1	Grille, Power Stand, Left	317363-010S	4135+8921+0	
2	Grille, Power Stand, Right	317364-010S	4135-8931+0	
3	Guide, Array, ABS, Blk	-	4155-3811+0	
4	Woofer, 8 inch	317370-000S	SVC-8900-6980+0	
5	Screw, M4x25mm	-	2900-4025+3000	4
6	Screw, M4x14	-	2904-4014+3000	4
7	Enclosure, Top, Silk Screened	317346-010S	1468-5501+0	
8	Carry Handle, Power Stand	317353-010S	4155-3781+0	
9	Bolt, Power Stand Carry Handle, M6	317359-010S	4135-8951+0	
10	PCB Assy, IO COM (Pre-amp PCB ASSY)	319966-000S	SVC-CAJUN01+I/O	2
11	Knob, Channel 1/2	317349-010S	2447-8401+0	
12	Knob, Volume/Treble	317350-010S	2447-8501+0	
13	Knob, Line Level	317351-010S	2447-8601+0	
14	Screw, Machine, Flat, CS, M4x12	-	2901-4012+3000	4
15	Screw, CSH, Blk	-	2901-3012+3000	4
16	Panel, Access	317348-010S	1468-5701+0	
17	Switch, Power, DPST, 250V, 10A	317373-000S	5200-4969+0	3 
18	Inlet, AC, UL/CSA/VDE, 250V	-	2113-1144+0	3 
19	Screw, M3x12, CSH, Blk	-	2901-3012+3000	4
20	Nut, M4	-	2640-4030+0703	4
21	Heatsink, Amplifier PCB, 160x120mm	-	5401-0191+0	4
22	PCB Assy, Amp/SMPS	317372-000S	SVC-CAJUN11+PAMP	2
23	Screw, Machine, M4	-	2904-4020+3000	4
24	Enclosure, Bottom	317347-010S	1468-5601+0	
25	Foot, Rubber, 31x31x10	298057	4157-1191+0	3 
26	Screw, B-tite, Bind, M4x12	-	2954-4012+3000	4
27	Screw, Machine, M4x25, 7.8mm	-	2900-4025+3000	4
28	Screw, B-tite, Flat-CS, M3x12	-	2951-3012+0000	4
-	Guide Track, Bass	317358-010S	4155-3841+0	
-	FUSE, 5A, 250V, 8X8.5, VDE/PSE/CCC, RLT LITTELFUSE, JAPAN/EURO/UK	317381-000S	5120-1136+0-L	3 
-	FUSE, 5A, 250V, 8X8.5 UL/CSA RLT LITTELFUSE, US/CAN	319970-000S	5120-1140+0-L	3 
-	Ribbon Cable, I/O Board to AMP/SMPS, WIRE-CONN, 10P, P2.0, #26, UL2468 F/F	319983-000S	7013-0590+0	3 
-	Cable Assy, AMP/SMPS to Woofer, WIRE-SPK, 2P, VH3.96-2Y, #20, UL2468, L400, R/B, 205/110T	319984-000S	7013-0780+0	3 
-	Cable Assy, AMP/SMPS to Twiddler Conn., WIRE, 2P, VH3.96-3Y, #20, UL 2468, L=500, R/B, WM17700ND	319985-000S	7013-0730+0	3 

Main Part List

L1 Compact Power Stand, continued (see Figure 3)

Item Number	Description	Bose® Part Number	Vendor Part Number	Note
-	PCB Assy, COB COM (Includes: PRE-AMP ASSY/3.5MM Jack Input Card/Line Output Card)	317371-000S	SVC-CAJUN01+COB	2
-	PCB Assy, IN COM (3.5MM Jack Input Card)	319967-000S	SVC-CAJUN01+IN	2
-	PCB Assy, OUT COM (Line Output Card)	319968-000S	SVC-CAJUN01+OUT	2

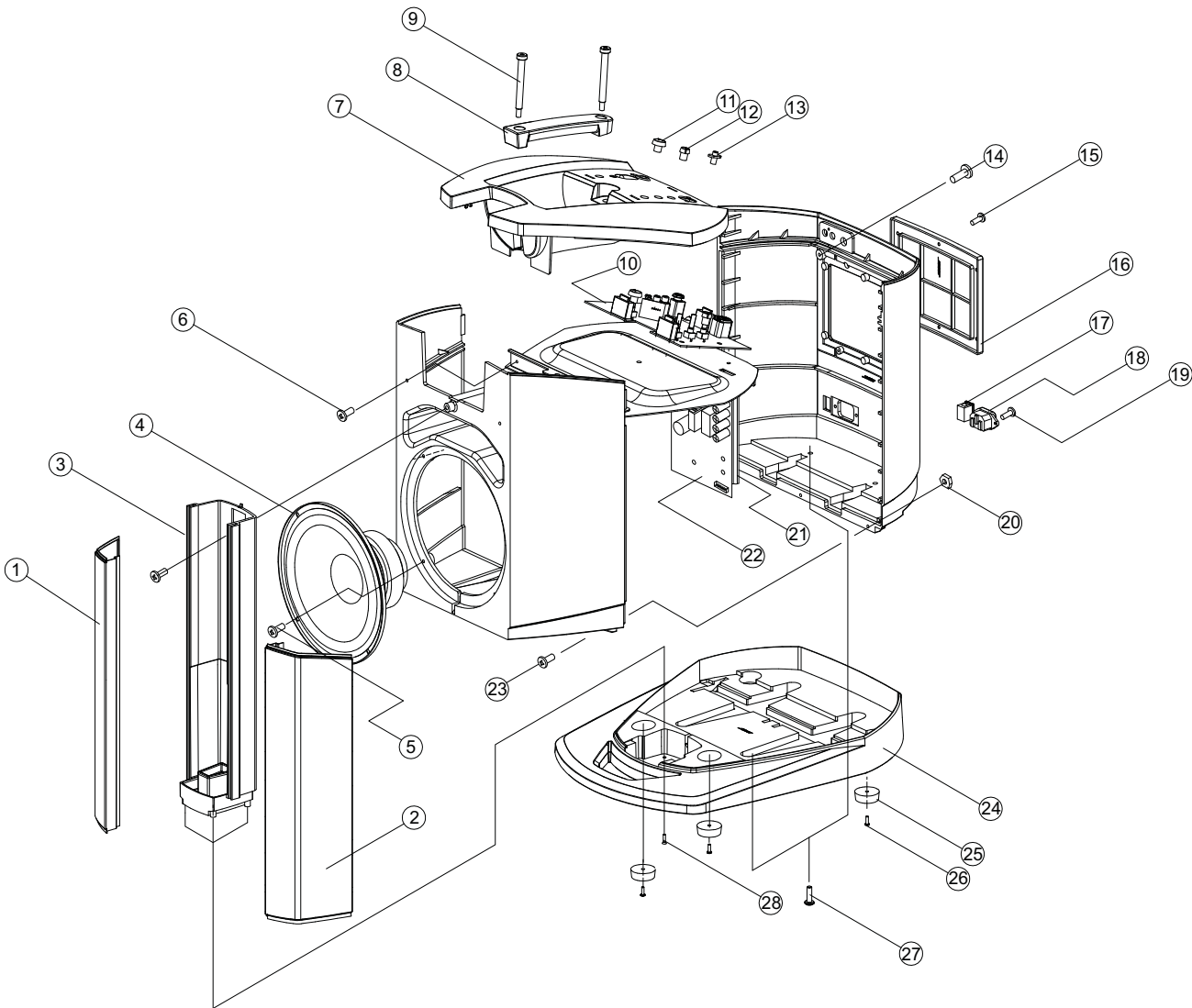

Figure 3. L1 Compact Power Stand Exploded View

Main Part List

L1 Compact Array Speaker (see Figure 4)

Item Number	Description	Bose® Part Number	Vendor Part Number	Note
1	Handle, Array	-	4155-3851+0	4
2	Screw, B-tite, Bind, M3x16, CS-Recess	-	2954-3016+3000	4
3	Enclosure, Array, ABS	-	4155-3801+0	4
4	Baffle, Array, ABS, Black	-	4155-3791+0	4
5	Twiddler, 2.5 inch	359302-0010	-	3 ⚠
6	Screw, M3x10, BT, ZN, Blk	-	2934-3010+3000	4
7	Grille, Array (W/Logo)	317365-010S	svc-cajun01+gril	
8	Butyl Tape	-	9500-1101+0	4
9	Wire, Spk, 2P, #20, UL1007, L=250/180, RD/BLK	-	7013-0760+0	3, 4 ⚠
10	Array Logo	317407-010S	2150-7311+0	
11	EVA Gasket, Baffle	-	4149-1121+0	4
12	Screw, M3x13, 5.6MM, BK-ZN/CR HD	-	2931-3013+3000	4
13	Label, Serial Number, 30x7mm	-	-	4
14	Guide Strip, Array	317366-010S	4155-3861+0	
15	Screw, M3x12, CSH, BK	-	2901-3012+3000	4

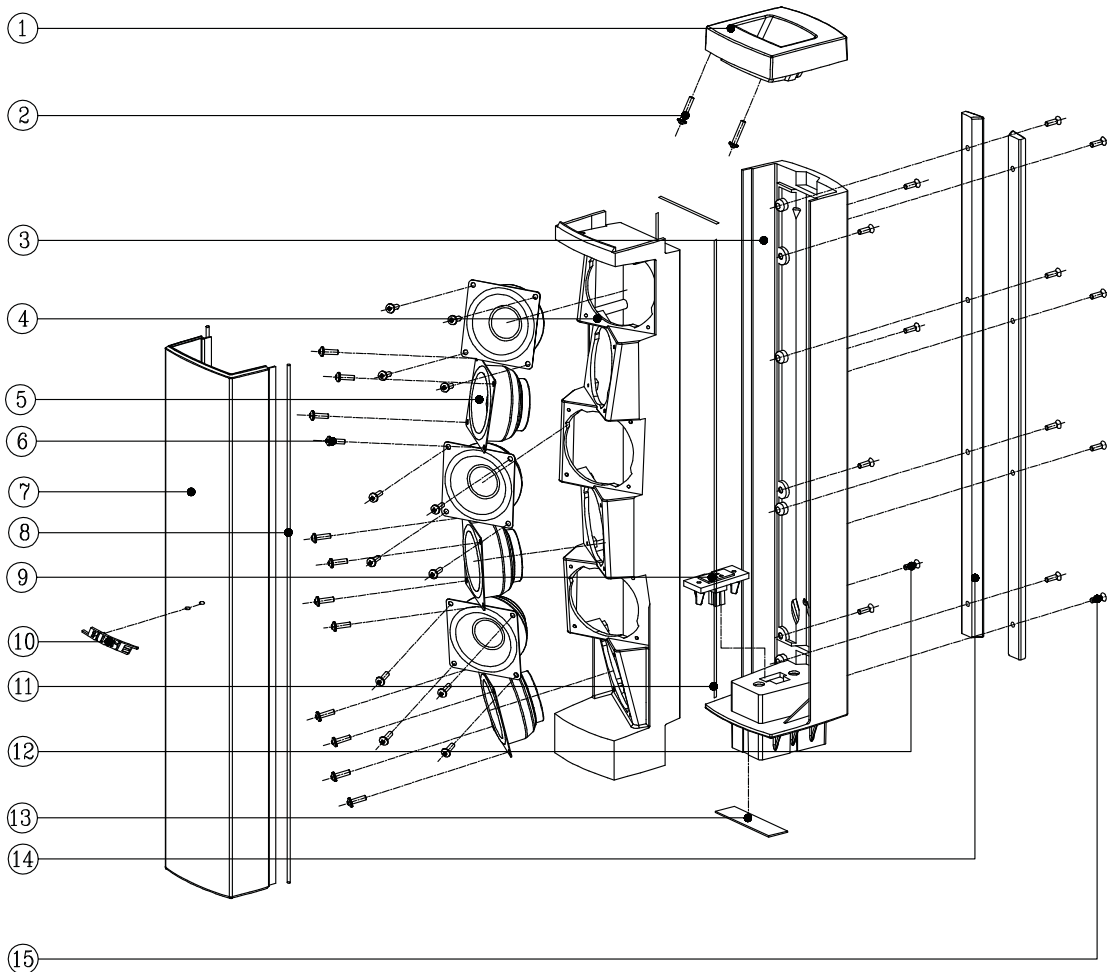

Figure 4. L1 Compact Array Speaker Exploded View

Main Part List

L1 Compact Array Extension Exploded View (see Figure 5)

Item Number	Description	Bose® Part Number	Vendor Part Number	Note
-	Array Extension, Complete Assembly, Consists of below items	318881-010S	svc-cajun11+exte	
1	Wire, 2P, #20, UL2468, L=850 Red/Blk, Molex MDI	-	7013-0750+0	3, 4 ⚠
2	Label, Serial Number, 30x7mm	-	-	4
3	Screw, B-tite, Flat-CS, M3x16, CS-Recess, BZ	-	2951-3016+3000	4
4	Extension Front, ABS, Blk	-	4155-3821+0	4
5	Extension Rear, ABS, Blk	-	4155-3831+0	4
6	MS Screw, M3x12, CSH, BK	-	2901-3012+3000	4
7	Guide Strip, POM, Blk	-	4155-3861+0	4
8	Gasket	-	4153-3431+0	4
9	Screw, Machine, Flat-CS, M3x40, CS-Recess, BZ	-	2901-3040+3000	4

Note: The array extensions are not repairable. The above parts are listed for reference only.

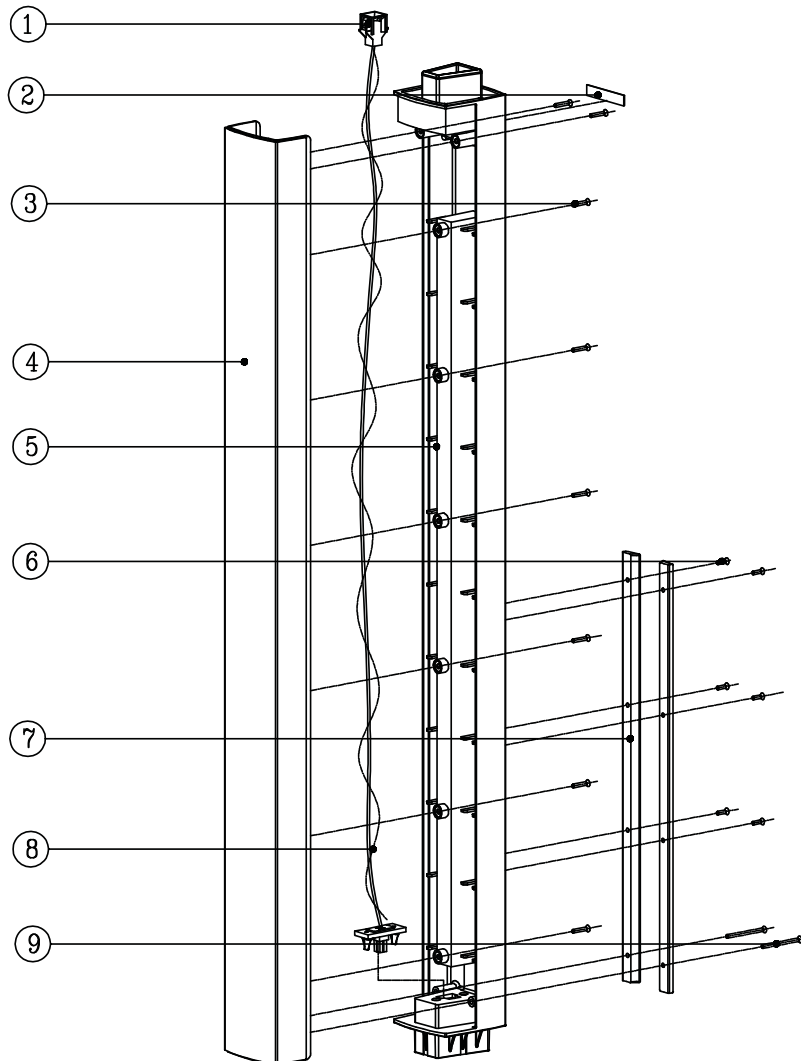

Figure 5. L1 Compact Array Extension Exploded View

Electrical Part List

Input/Output PCB Assembly

Resistors

Reference Designator	Description	Vendor Part Number	Note
R100	100 OHM, RMG, 1/16W, 1%, 0603	4723-101A+P	4
R101	100 OHM, RMG, 1/16W, 1%, 0603	4723-101A+P	4
R102	2K, RMG, 1/16W, 1%, 0603/1608	4723-202A+P	4
R103	2K, RMG, 1/16W, 1%, 0603/1608	4723-202A+P	4
R104	4.99K, RMG, 1/16W, 1%, 0603	4723-4991+P	4
R105	4.99K, RMG, 1/16W, 1%, 0603	4723-4991+P	4
R106	4.99K, RMG, 1/16W, 1%, 0603	4723-4991+P	4
R107	4.99K, RMG, 1/16W, 1%, 0603	4723-4991+P	4
R108	10K, RMG, 1/16W, 1%, 0603/1608	4723-103A+P	4
R109	10K, RMG, 1/16W, 1%, 0603/1608	4723-103A+P	4
R110	1K, RMG, 1/16W, 1%, 0603/1608	4723-102A+P	4
R111	1K, RMG, 1/16W, 1%, 0603/1608	4723-102A+P	4
R112	0 OHM, RMG, 1/16W, 5%, 0603	4723-000J+P-R	4
R113	1K, RMG, 1/16W, 1%, 0603/1608	4723-102A+P	4
R114	150 OHM, RMG, 1/16W, 1%, 0603	4723-151A+P-R	4
R115	150 OHM, RMG, 1/16W, 1%, 0603	4723-151A+P-R	4
R116	2.2K, RMG, 1/16W, 1%, 0603/1608	4723-222A+P	4
R117	150 OHM, RMG, 1/16W, 1%, 0603	4723-151A+P	4
R118	1M, RMG, 1/16W, 1%, 0603	4723-105A+P	4
R119	1M, RMG, 1/16W, 1%, 0603	4723-105A+P	4
R120	100K, RMG, 1/16W, 1%, 0603	4723-104A+P	4
R122	39K, RMG, 1/10W, 1%, 0603	4720-393A+P	4
R123	39K, RMG, 1/10W, 1%, 0603	4720-393A+P	4
R124	12K, RMG, 1/16W, 1%, 0603	4723-123A+P	4
R125	150 OHM, RMG, 1/16W, 1%, 0603	4723-154A+P-R	4
R126	75K, RMG, 1/16W, 1%, 0603	4723-753A+P	4
R127	8.87K, RMG, 1/16W, 1%, 0603/1608	4723-8871+P	4
R128	47K, RMG, 1/16W, 1%, 0603/1608	4723-473A+P	4
R129	60.4K, RMG, 1/16W, 1%, 0603/1608	4723-6042+P	4
R130	1K, RMG, 1/16W, 1%, 0603/1608	4723-102A+P	4
R131	10K, RMG, 1/16W, 1%, 0603/1608	4723-103A+P	4
R132	10K, RMG, 1/16W, 1%, 0603/1608	4723-103A+P	4
R133	100K, RMG, 1/16W, 1%, 0603	4723-104A+P-R	4
R134	100K, RMG, 1/16W, 1%, 0603	4723-104A+P-R	4
R135	97.6K, RMG, 1/10W, 1%, 0603	4720-9762+P	4
R136	100K, RMG, 1/16W, 1%, 0603	4723-104A+P-R	4
R137	0 OHM, RMG, 1/16W, 5%, 0603	4723-000J+P-R	4
R138	0 OHM, RMG, 1/16W, 5%, 0603	4723-000J+P-R	4
R139	100K, RMG, 1/16W, 1%, 0603	4723-104A+P-R	4
R140	100K, RMG, 1/16W, 1%, 0603	4723-104A+P-R	4
R141	10K, RMG, 1/16W, 1%, 0603	4723-103A+P-R	4
R142	43.2K, RMG, 1/10W, 1%, 0603	4720-4322+P	4
R143	100K, RMG, 1/16W, 1%, 0603	4723-104A+P-R	4
R144	100K, RMG, 1/16W, 1%, 0603	4723-104A+P-R	4
R145	100K, RMG, 1/16W, 1%, 0603	4723-104A+P-R	4
R146	100K, RMG, 1/16W, 1%, 0603	4723-104A+P-R	4
R147	10K, RMG, 1/16W, 1%, 0603	4723-103A+P-R	4

Electrical Part List

Input/Output PCB Assembly

Resistors (continued)

Reference Designator	Description	Vendor Part Number	Note
R148	10K, RMG, 1/16W, 1%, 0603	4723-103A+P-R	4
R149	270 OHM, RMG, 1/16W, 1%, 0603	4723-271A+P-R	4
R150	270 OHM, RMG, 1/16W, 1%, 0603	4723-271A+P-R	4
R151	34.8K, RMG, 1/10W, 1%, 0603	4720-3482+P	4
R152	68K, RMG, 1/16W, 1%, 0603	4723-683A+P-R	4
R153	10K, RMG, 1/16W, 1%, 0603	4723-103A+P-R	4
R154	48.7K, RMG, 1/10W, 1%, 0603	4720-4872+P	4
R155	17.8K, RMG, 1/16W, 1%, 0603/1608	4723-1782+P	4
R156	20K, RMG, 1/16W, 1%, 0603/1608	4723-203A+P	4
R157	10K, RMG, 1/16W, 1%, 0603	4723-103A+P-R	4
R158	6.81K, RMG, 1/10W, 1%, 0603	4720-6811+P	4
R159	13.7K, RMG, 1/10W, 1%, 0603	4720-1372+P	4
R160	10K, RMG, 1/16W, 1%, 0603	4723-103A+P-R	4
R161	10K, RMG, 1/16W, 1%, 0603	4723-103A+P-R	4
R162	1K, RMG, 1/16W, 1%, 0603/1608	4723-102A+P	4
R163	24K, RMG, 1/16W, 1%, 0603	4723-243A+P	4
R164	24K, RMG, 1/16W, 1%, 0603	4723-243A+P	4
R165	100K, RMG, 1/16W, 1%, 0603	4723-104A+P-R	4
R166	22K, RMG, 1/16W, 1%, 0603	4723-223A+P-R	4
R167	8.87K, RMG, 1/16W, 1%, 0603/1608	4723-8872+P	4
R168	12K, RMG, 1/16W, 1%, 0603	4723-123A+P	4
R169	3K, RMG, 1/16W, 1%, 0603	4723-302A+P	4
R170	24K, RMG, 1/16W, 1%, 0603	4723-243A+P	4
R172	820 OHM, RMG, 1/16W, 1%, 0603/1608	4723-821A+P	4
R173	820 OHM, RMG, 1/16W, 1%, 0603/1608	4723-821A+P	4
R174	0 OHM, RMG, 1/16W, 5%, 0603	4723-000J+P-R	4
R175	0 OHM, RMG, 1/16W, 5%, 0603	4723-000J+P	4
R177	510 OHM, RMG, 1/4W, 5%, 1206	4725-511J+6	4
R178	510 OHM, RMG, 1/4W, 5%, 1206	4725-511J+6	4
R179	100K, RMG, 1/16W, 1%, 0603	4723-104A+P-R	4
R180	15.8K, RMG, 1/10W, 1%, 0603	4720-1582+P	4
R181	470K, RMG, 1/16W, 1%, 0603	4723-474A+P	4
R182	0 OHM, RMG, 1/16W, 5%, 0603	4723-000J+P-R	4
R183	24K, RMG, 1/16W, 1%, 0603	4723-243A+P	4
R184	100K, RMG, 1/16W, 1%, 0603	4723-104A+P-R	4
R186	1M, RMG, 1/16W, 1%, 0603	4723-105A+P	4
R188	10 OHM, RMG, 1/16W, 1%, 0603	4723-100A+P-R	4
R189	10 OHM, RMG, 1/16W, 1%, 0603	4723-100A+P-R	4
R190	1M, RMG, 1/16W, 1%, 0603	4723-105A+P	4
R199	100 OHM, RMG, 1/16W, 1%, 0603	4723-101A+P	4
R200	45.3K, RMG, 1/10W, 1%, 0603	4720-4532+P	4
R201	95.3K, RMG, 1/10W, 1%, 0603	4720-9532+P	4
R202	59K, RMG, 1/10W, 1%, 0603	4720-593A+P	4
R203	12K, RMG, 1/16W, 1%, 0603	4723-123A+P	4
R204	7.87K, RMG, 1/10W, 1%, 0603	4720-7871+P	4
R205	9.76K, RMG, 1/16W, 1%, 0603	4723-9761+P	4
R206	9.76K, RMG, 1/16W, 1%, 0603	4723-9761+P	4
R207	95.3K, RMG, 1/10W, 1%, 0603	4720-9532+P	4
R208	7.87K, RMG, 1/10W, 1%, 0603	4720-7871+P	4

Electrical Part List

Input/Output PCB Assembly

Resistors (continued)

Reference Designator	Description	Vendor Part Number	Note
R209	12K, RMG, 1/16W, 1%, 0603	4723-123A+P	4
R210	150 OHM, RMG, 1/16W, 1%, 0603	4723-154A+P-R	4
R211	75K, RMG, 1/16W, 1%, 0603	4723-753A+P	4
R213	1K, RMG, 1/16W, 1%, 0603/1608	4723-102A+P	4
R214	1K, RMG, 1/16W, 1%, 0603/1608	4723-102A+P	4
R215	100 OHM, RMG, 1/16W, 1%, 0603	4723-101A+P	4
R216	10K, RMG, 1/16W, 1%, 0603/1608	4723-103A+P	4
R217	1K, RMG, 1/16W, 1%, 0603/1608	4723-102A+P	4
R218	20K, RMG, 1/16W, 1%, 0603/1608	4723-203A+P	4
R219	2K, RMG, 1/16W, 1%, 0603/1608	4723-202A+P	4
R220	4.99K, RMG, 1/16W, 1%, 0603	4723-4991+P	4
R222	68K, RMG, 1/16W, 1%, 0603	4723-683A+P-R	4
R223	100K, RMG, 1/16W, 1%, 0603	4723-104A+P	4
R224	10K, RMG, 1/16W, 1%, 0603/1608	4723-103A+P	4
R225	1.8M, RMG, 1/16W, 1%, 0603	4723-185A+P	4
R226	10K, RMG, 1/16W, 1%, 0603/1608	4723-103A+P	4
R227	1.8M, RMG, 1/16W, 1%, 0603	4723-185A+P	4
R228	100 OHM, RMG, 1/16W, 1%, 0603	4723-101A+P	4
R229	100 OHM, RMG, 1/16W, 1%, 0603	4723-101A+P	4
R230	1K, RMG, 1/16W, 1%, 0603/1608	4723-102A+P	4
R231	0 OHM, RMG, 1/16W, 5%, 0603	4723-000J+P	4
R232	1M, RMG, 1/16W, 1%, 0603	4723-105A+P	4
R234	0 OHM, RMG, 1/16W, 5%, 0603	4723-000J+P-R	4
R236	3.9K, RMG, 1/16W, 1%, 0603/1608	4723-392A+P	4
R238	2K, RMG, 1/16W, 1%, 0603/1608	4723-202A+P	4
R239	2K, RMG, 1/16W, 1%, 0603/1608	4723-202A+P	4
R240	3.9K, RMG, 1/16W, 1%, 0603/1608	4723-392A+P	4
R241	3.9K, RMG, 1/16W, 1%, 0603/1608	4723-392A+P	4
R243	0 OHM, RMG, 1/16W, 5%, 0603	4723-000J+P-R	4
R244	10K, RMG, 1/16W, 1%, 0603	4723-103A+P-R	4
R245	10K, RMG, 1/16W, 1%, 0603	4723-103A+P-R	4
R246	1.8M, RMG, 1/16W, 1%, 0603	4723-185A+P	4
R247	59K, RMG, 1/10W, 1%, 0603	4720-593A+P	4
R248	1M, RMG, 1/16W, 1%, 0603	4723-105A+P	4
R249	20K, RMG, 1/16W, 1%, 0603/1608	4723-203A+P	4
R250	24K, RMG, 1/16W, 1%, 0603	4723-243A+P	4
R251	1M, RMG, 1/16W, 1%, 0603	4723-105A+P	4
R254	24K, RMG, 1/16W, 1%, 0603	4723-243A+P	4
R255	68K, RMG, 1/16W, 1%, 0603	4723-683A+P-R	4
R257	68K, RMG, 1/16W, 1%, 0603	4723-683A+P-R	4
R258	10 OHM, RMG, 1/16W, 1%, 0603	4723-100A+P-R	4
R260	100 OHM, RMG, 1/16W, 1%, 0603	4723-101A+P	4
R262	100K, RMG, 1/16W, 1%, 0603	4723-104A+P	4
R264	1.8M, RMG, 1/16W, 1%, 0603	4723-185A+P	4
R265	6.8K, RMG, 1/16W, 1%, 0603/1608	4723-682A+P	4
R266	6.8K, RMG, 1/16W, 1%, 0603/1608	4723-682A+P	4
R267	22.6K, RMG, 1/10W, 1%, 0603	4720-2262+P	4
R271	510 OHM, RMG, 1/4W, 5%, 1206	4725-511J+6	4

Electrical Part List

Input/Output PCB Assembly

Resistors (continued)

Reference Designator	Description	Vendor Part Number	Note
R272	510 OHM, RMG, 1/4W, 5%, 1206	4725-511J+6	4
R275	100K, RMG, 1/16W, 1%, 0603	4723-104A+P-R	4
R276	15.8K, RMG, 1/10W, 1%, 0603	4720-1582+P	4
R277	470K, RMG, 1/16W, 1%, 0603	4723-474A+P	4
R278	0 OHM, RMG, 1/16W, 5%, 0603	4723-000J+P-R	4
R279	24K, RMG, 1/16W, 1%, 0603	4723-243A+P	4
R280	100K, RMG, 1/16W, 1%, 0603	4723-104A+P-R	4
R282	1M, RMG, 1/16W, 1%, 0603	4723-105A+P	4
R283	68K, RMG, 1/16W, 1%, 0603	4723-683A+P-R	4
R285	2.2K, RMG, 1/16W, 1%, 0603/1608	4723-222A+P	4
R287	100K, RMG, 1/16W, 1%, 0603	4723-104A+P	4
R288	2K, RMG, 1/16W, 1%, 0603/1608	4723-202A+P	4
R289	33K, RMG, 1/16W, 1%, 0603	4723-333A+P-R	4
R290	15.8K, RMG, 1/10W, 1%, 0603	4720-1582+P	4
R300	33K, RMG, 1/16W, 1%, 0603	4723-333A+P-R	4
R301	68K, RMG, 1/16W, 1%, 0603	4723-683A+P-R	4
R302	91K, RMG, 1/10W, 1%, 0603	4720-913A+P	4
R303	68K, RMG, 1/16W, 1%, 0603	4723-683A+P-R	4
R304	10K, RMG, 1/16W, 1%, 0603	4723-103A+P-R	4
R305	100K, RMG, 1/16W, 1%, 0603	4723-104A+P-R	4
R306	10K, RMG, 1/16W, 1%, 0603	4723-103A+P-R	4
R307	20K, RMG, 1/16W, 1%, 0603/1608	4723-203A+P	4
R308	100K, RMG, 1/16W, 1%, 0603	4723-104A+P-R	4
R309	33K, RMG, 1/16W, 1%, 0603	4723-333A+P-R	4
R311	10K, RMG, 1/16W, 1%, 0603	4723-103A+P-R	4
R312	10K, RMG, 1/16W, 1%, 0603	4723-103A+P-R	4
R313	100K, RMG, 1/16W, 1%, 0603	4723-104A+P-R	4
R314	10K, RMG, 1/16W, 1%, 0603	4723-103A+P-R	4
R315	10K, RMG, 1/16W, 1%, 0603	4723-103A+P-R	4
R316	20K, RMG, 1/16W, 1%, 0603/1608	4723-203A+P	4
R317	10K, RMG, 1/16W, 1%, 0603	4723-103A+P-R	4
R318	13.7K, RMG, 1/10W, 1%, 0603	4720-1372+P	4
R319	13.7K, RMG, 1/10W, 1%, 0603	4720-1372+P	4
R320	200K, RMG, 1/16W, 1%, 0603/1608	4723-204A+P	4
R321	20K, RMG, 1/16W, 1%, 0603/1608	4723-203A+P	4
R322	20K, RMG, 1/16W, 1%, 0603/1608	4723-203A+P	4
R325	1K, RMG, 1/16W, 1%, 0603/1608	4723-102A+P	4
R326	330 OHM, RMG, 1/16W, 1%, 0603	4723-331A+P	4
R327	10 OHM, RMG, 1/16W, 1%, 0603	4723-100A+P-R	4
R328	470 OHM, RMG, 1/16W, 1%, 0603	4723-471A+P-R	4
R329	470 OHM, RMG, 1/16W, 1%, 0603	4723-471A+P-R	4
R332	20K, RMG, 1/16W, 1%, 0603/1608	4723-203A+P	4
R333	80.6K, RMG, 1/10W, 1%, 0603	4720-8062+P	4
R334	3K, RMG, 1/16W, 1%, 0603	4723-302A+P	4
R335	10K, RMG, 1/16W, 1%, 0603/1608	4723-103A+P	4
R336	24K, RMG, 1/16W, 1%, 0603	4723-243A+P	4
R337	20K, RMG, 1/16W, 1%, 0603/1608	4723-203A+P	4
R338	39K, RMG, 1/16W, 1%, 0603/1608	4723-393A+P	4
R339	10K, RMG, 1/16W, 1%, 0603	4723-103A+P-R	4

Electrical Part List

Input/Output PCB Assembly

Resistors (continued)

Reference Designator	Description	Vendor Part Number	Note
R340	10K, RMG, 1/16W, 1%, 0603	4723-103A+P-R	4
R341	158K, RMG, 1/10W, 1%, 0603	4720-1583+P	4
R342	23.2K, RMG, 1/16W, 1%, 0603/1608	4723-2322+P	4
R343	24.3K, RMG, 1/10W, 1%, 0603	4720-2432+P	4
R344	24.3K, RMG, 1/10W, 1%, 0603	4720-2432+P	4
R345	10K, RMG, 1/16W, 1%, 0603	4723-103A+P-R	4
R346	10K, RMG, 1/16W, 1%, 0603	4723-103A+P-R	4
R347	14K, RMG, 1/16W, 1%, 0603/1608	4723-143A+P	4
R348	7.15K, RMG, 1/16W, 1%, 0603/1608	4723-7151+P	4
R349	1M, RMG, 1/16W, 1%, 0603	4723-105A+P	4
R351	80.6K, RMG, 1/10W, 1%, 0603	4720-8062+P	4
R352	20K, RMG, 1/16W, 1%, 0603/1608	4723-203A+P	4
R353	100K, RMG, 1/16W, 1%, 0603	4723-104A+P	4
R354	4.99K, RMG, 1/16W, 1%, 0603	4723-4991+P	4
R356	5.36K, RMG, 1/10W, 1%, 0603	4720-5361+P	4
R357	100K, RMG, 1/16W, 1%, 0603	4723-104A+P-R	4
R358	1.96K, RMG, 1/10W, 1%, 0603	4720-1961+P	4
R359	14K, RMG, 1/16W, 1%, 0603	4723-143A+P	4
R366	107K, RMG, 1/10W, 1%, 0603	4720-1073+P	4
R367	1K, RMG, 1/16W, 1%, 0603/1608	4723-102A+P	4
R368	53.6K, RMG, 1/10W, 1%, 0603	4720-5362+P	4
R369	100K, RMG, 1/16W, 1%, 0603	4723-104A+P-R	4
R373	8.45K, RMG, 1/10W, 1%, 0603	4720-8451+P	4
R376	23.2K, RMG, 1/16W, 1%, 0603/1608	4723-2322+P	4
R378	107K, RMG, 1/10W, 1%, 0603	4720-1073+P	4
R381	97.6K, RMG, 1/10W, 1%, 0603	4720-9762+P	4
R386	470K, RMG, 1/16W, 1%, 0603	4723-474A+P	4
R391	470K, RMG, 1/16W, 1%, 0603	4723-474A+P	4
R392	47K, RMG, 1/16W, 1%, 0603	4723-473A+P-R	4
R393	24K, RMG, 1/16W, 1%, 0603	4723-243A+P	4
R394	33K, RMG, 1/16W, 1%, 0603	4723-333A+P-R	4
R395	10K, RMG, 1/16W, 1%, 0603/1608	4723-103A+P	4
R396	33K, RMG, 1/16W, 1%, 0603	4723-333A+P-R	4
R397	47K, RMG, 1/16W, 1%, 0603	4723-473A+P-R	4
R399	0 OHM, RMG, 1/16W, 5%, 0603	4723-000J+P	4
R400	33K, RMG, 1/16W, 1%, 0603	4723-333A+P-R	4
R401	47 OHM, RMG, 1/2W, 1%, 2010	4727-470A+W	4
R402	20K, RMG, 1/16W, 1%, 0603/1608	4723-203A+P	4
R403	4.7M, RMG, 1/10W, 1%, 0603	4720-475A+P	4
R404	20K, RMG, 1/16W, 1%, 0603/1608	4723-203A+P	4
R405	20K, RMG, 1/16W, 1%, 0603/1608	4723-203A+P	4
R406	47 OHM, RMG, 1/2W, 1%, 2010	4727-470A+W	4
R407	68K, RMG, 1/16W, 1%, 0603	4723-683A+P-R	4
R408	100 OHM, RMG, 1/16W, 1%, 0603	4723-101A+P	4
R409	100 OHM, RMG, 1/16W, 1%, 0603	4723-101A+P	4
R410	100 OHM, RMG, 1/16W, 1%, 0603	4723-101A+P	4
R411	100 OHM, RMG, 1/16W, 1%, 0603	4723-101A+P	4
R412	158K, RMG, 1/10W, 1%, 0603	4720-1583+P	4

Electrical Part List

Input/Output PCB Assembly

Resistors (continued)

Reference Designator	Description	Vendor Part Number	Note
R413	24.3K, RMG, 1/10W, 1%, 0603	4720-2432+P	4
R414	24.3K, RMG, 1/10W, 1%, 0603	4720-2432+P	4
R424	20K, RMG, 1/16W, 1%, 0603/1608	4723-203A+P	4
R425	1M, RMG, 1/16W, 1%, 0603	4723-105A+P	4
R426	510 OHM, RMG, 1/4W, 5%, 1206	4725-511J+6	4
R427	68K, RMG, 1/16W, 1%, 0603	4723-683A+P-R	4
R428	82K, RMG, 1/10W, 1%, 0603	4720-823A+P	4
R432	200K, RMG, 1/16W, 1%, 0603/1608	4723-204A+P	4
R433	100K, RMG, 1/16W, 1%, 0603	4723-104A+P-R	4
R435	1M, RMG, 1/16W, 1%, 0603	4723-105A+P	4
R440	4.7M, RMG, 1/10W, 1%, 0603	4720-475A+P	4
R441	20K, RMG, 1/16W, 1%, 0603/1608	4723-203A+P	4
R449	1K, RMG, 1/16W, 1%, 0603/1608	4723-102A+P	4
R450	34K, RMG, 1/10W, 1%, 0603	4720-343A+P	4
R451	12K, RMG, 1/16W, 1%, 0603	4723-123A+P-R	4
R452	200K, RMG, 1/16W, 1%, 0603/1608	4723-204A+P	4
R453	100 OHM, RMG, 1/16W, 1%, 0603	4723-101A+P	4
R500	200K, RMG, 1/16W, 1%, 0603/1608	4723-204A+P	4
R501	47 OHM, RMG, 1/2W, 1%, 2010	4727-470A+W	4
R502	47 OHM, RMG, 1/2W, 1%, 2010	4727-470A+W	4
R503	100 OHM, RMG, 1/16W, 1%, 0603	4723-101A+P	4
R504	100 OHM, RMG, 1/16W, 1%, 0603	4723-101A+P	4
R505	270 OHM, RMG, 1/16W, 1%, 0603	4723-271A+P-R	4
R506	0 OHM, RMG, 1/16W, 5%, 0603	4723-000J+P	4
R507	6.8K, RMG, 1/16W, 1%, 0603/1608	4723-682A+P	4
R508	6.8K, RMG, 1/16W, 1%, 0603/1608	4723-682A+P	4
R509	6.8K, RMG, 1/16W, 1%, 0603/1608	4723-682A+P	4
R510	2.2K, RMG, 1/16W, 1%, 0603/1608	4723-222A+P	4
R511	10K, RMG, 1/16W, 1%, 0603/1608	4723-103A+P	4
R512	3.3K, RMG, 1/16W, 1%, 0603/1608	4723-332A+P	4
R513	3.3K, RMG, 1/16W, 1%, 0603/1608	4723-332A+P	4
R514	100K, RMG, 1/16W, 1%, 0603	4723-104A+P-R	4
R515	10K, RMG, 1/16W, 1%, 0603	4723-103A+P-R	4
R517	1K, RMG, 1/16W, 1%, 0603/1608	4723-102A+P	4
R518	270 OHM, RMG, 1/16W, 1%, 0603	4723-271A+P-R	4
R519	150 OHM, RMG, 1/16W, 1%, 0603	4723-154A+P-R	4
R521	100 OHM, RMG, 1/16W, 1%, 0603	4723-101A+P	4
R525	1K, RMG, 1/16W, 1%, 0603/1608	4723-102A+P	4

Electrical Part List

Input/Output PCB Assembly

Capacitors

Reference Designator	Description	Vendor Part Number	Note
C100	0.1uF, CC, 50V, 5%, 0603	150F-104J+P-AC	4
C101	0.01uF, CC, 50V, 5%, 0603	150F-103J+P-AC	4
C102	100pF, CC, 50V, 5%, 0603/1608, 1X2	150F-101J+P-AC	4
C103	100pF, CC, 50V, 5%, 0603/1608, 1X2	150F-101J+P-AC	4
C105	22uF, CE, 16V, 20%, RLT, 4X7, RC2	157D-226M+K-GME	4
C106	22uF, CE, 16V, 20%, RLT, 4X7, RC2	157D-226M+K-GME	4
C107	100pF, CC, 50V, 5%, 0603/1608, 1X2	150F-101J+P-AC	4
C108	100pF, CC, 50V, 5%, 0603/1608, 1X2	150F-101J+P-AC	4
C109	10uF, CE, 16V, 20%, RLT, 4X7, ELNA	157D-106M+K-GME	4
C110	0.047uF, CC, 50V, 5%, 0603, 0.8X1.6	150F-473J+P-AC	4
C111	0.047uF, CC, 50V, 5%, 0603, 0.8X1.6	150F-473J+P-AC	4
C112	0.01uF, CC, 50V, 5%, 0603	150F-103J+P-AC	4
C113	0.01uF, CC, 50V, 5%, 0603	150F-103J+P-AC	4
C114	2200pF, CC, 50V, 10%, 0603, 0.8x1.6	150F-222K+P-AC	4
C115	0.1uF, CC, 50V, 5%, 0603	150F-104J+P-AC	4
C116	220uF, CE, 6.3V, 20%, RLT, 5X11	157B-227M+K-IUI	4
C117	220uF, CE, 6.3V, 20%, RLT, 5X11	157B-227M+K-IUI	4
C118	220uF, CE, 6.3V, 20%, RLT, 5X11	157B-227M+K-IUI	4
C119	0.1uF, CC, 50V, 5%, 0603	150F-104J+P-AC	4
C120	0.1uF, CC, 50V, 5%, 0603	150F-104J+P-AC	4
C121	0.1uF, CC, 50V, 5%, 0603	150F-104J+P-AC	4
C122	0.1uF, CC, 50V, 5%, 0603	150F-104J+P-AC	4
C123	0.1uF, CC, 50V, 5%, 0603	150F-104J+P-AC	4
C124	0.1uF, CC, 50V, 5%, 0603	150F-104J+P-AC	4
C125	0.1uF, CC, 50V, 5%, 0603	150F-104J+P-AC	4
C126	0.1uF, CC, 50V, 5%, 0603	150F-104J+P-AC	4
C127	0.1uF, CC, 50V, 5%, 0603	150F-104J+P-AC	4
C128	0.1uF, CC, 50V, 5%, 0603	150F-104J+P-AC	4
C129	0.1uF, CC, 50V, 5%, 0603	150F-104J+P-AC	4
C130	0.1uF, CC, 50V, 5%, 0603	150F-104J+P-AC	4
C131	0.1uF, CC, 50V, 5%, 0603	150F-104J+P-AC	4
C132	220uF, CE, 6.3V, 20%, RLT, 5X11	157B-227M+K-IUI	4
C133	0.1uF, CC, 50V, 5%, 0603	150F-104J+P-AC	4
C134	100pF, CC, 50V, 5%, 0603/1608, 1X2	150F-101J+P-AC	4
C135	0.1uF, CC, 50V, 5%, 0603	150F-104J+P-AC	4
C136	0.1uF, CC, 50V, 5%, 0603	150F-104J+P-AC	4
C137	0.1uF, CC, 50V, 5%, 0603	150F-104J+P-AC	4
C138	0.1uF, CC, 50V, 5%, 0603	150F-104J+P-AC	4
C139	0.1uF, CC, 50V, 5%, 0603	150F-104J+P-AC	4
C140	0.1uF, CC, 50V, 5%, 0603	150F-104J+P-AC	4
C141	0.1uF, CC, 50V, 5%, 0603	150F-104J+P-AC	4
C142	1000pF, CC, 50V, 5%, 0603, X7R	150F-102J+P-AC	4
C143	470pF, CC, 50V, 5%, 0603	150F-471J+P-AC	4
C144	470pF, CC, 50V, 5%, 0603	150F-471J+P-AC	4
C145	0.01uF, CC, 50V, 5%, 0603	150F-103J+P-AC	4
C146	10uF, CE, 16V, 20%, RLT, 4X7, ELNA	157D-106M+K-GME	4
C147	1200pF, CC, 50V, 5%, 0603, 0.8X1.6	150F-122J+P-AC	4

Electrical Part List

Input/Output PCB Assembly

Capacitors (continued)

Reference Designator	Description	Vendor Part Number	Note
C148	0.1uF, CC, 50V, 5%, 0603	150F-104J+P-AC	4
C149	10pF, CC, 50V, 5%, 0603	150F-100J+P-AC	4
C151	10uF, CE, 16V, 20%, RLT, 4X7, ELNA	157D-106M+K-GME	4
C152	100pF, CC, 50V, 5%, 0603/1608, 1X2	150F-101J+P-AC	4
C153	1000pF, CC, 50V, 5%, 0603, X7R	150F-102J+P-AC	4
C154	10uF, CE, 16V, 20%, RLT, 4X7, ELNA	157D-106M+K-GME	4
C156	10uF, CE, 16V, 20%, RLT, 4X7, ELNA	157D-106M+K-GME	4
C157	10uF, CE, 16V, 20%, RLT, 4X7, ELNA	157D-106M+K-GME	4
C158	0.047uF, CC, 50V, 5%, 0603, 0.8X1.6	150F-473J+P-AC	4
C159	0.047uF, CC, 50V, 5%, 0603, 0.8X1.6	150F-473J+P-AC	4
C160	100pF, CC, 50V, 5%, 0603/1608, 1X2	150F-101J+P-AC	4
C161	100pF, CC, 50V, 5%, 0603/1608, 1X2	150F-101J+P-AC	4
C162	470pF, CC, 50V, 5%, 0603	150F-471J+P-AC	4
C166	2000pF, CC, 50V, 5%, 0603, 0.8X1.6	150F-202J+P-AC	4
C169	1uF, CC, 25V, 5%, 0805, 1.25X2	150E-105J+J-BD	4
C170	1800pF, CC, 50V, 5%, 0603, 0.8X1.6	150F-182J+P-AC	4
C171	0.47uF, CC, 25V, 5%, 0805, 1.25X2	150E-474J+J-BD	4
C172	1uF, CE, 50V, 20%, RLT, 4X7, ELNA	157F-105M+K-GME	4
C173	0.1uF, CC, 50V, 5%, 0603	150F-104J+P-AC	4
C174	47uF, CE, 16V, 20%, RLT, 5X7	157D-476M+K-IME	4
C175	47uF, CE, 16V, 20%, RLT, 5X7	157D-476M+K-IME	4
C200	0.1uF, CC, 50V, 5%, 0603	150F-104J+P-AC	4
C201	0.1uF, CC, 50V, 5%, 0603	150F-104J+P-AC	4
C202	100pF, CC, 50V, 5%, 0603/1608, 1X2	150F-101J+P-AC	4
C208	0.1uF, CC, 50V, 5%, 0603	150F-104J+P-AC	4
C209	0.1uF, CC, 50V, 5%, 0603	150F-104J+P-AC	4
C210	0.1uF, CC, 50V, 5%, 0603	150F-104J+P-AC	4
C211	0.1uF, CC, 50V, 5%, 0603	150F-104J+P-AC	4
C212	0.1uF, CC, 50V, 5%, 0603	150F-104J+P-AC	4
C213	0.1uF, CC, 50V, 5%, 0603	150F-104J+P-AC	4
C214	0.022uF, CC, 50V, 10%, 0603	150F-223K+P-AC	4
C215	0.022uF, CC, 50V, 10%, 0603	150F-223K+P-AC	4
C216	0.1uF, CC, 50V, 5%, 0603	150F-104J+P-AC	4
C217	0.1uF, CC, 50V, 5%, 0603	150F-104J+P-AC	4
C218	0.1uF, CC, 50V, 5%, 0603	150F-104J+P-AC	4
C219	0.1uF, CC, 50V, 5%, 0603	150F-104J+P-AC	4
C220	0.1uF, CC, 50V, 5%, 0603	150F-104J+P-AC	4
C221	0.1uF, CC, 50V, 5%, 0603	150F-104J+P-AC	4
C222	1000pF, CC, 50V, 5%, 0603, X7R	150F-102J+P-AC	4
C225	0.01uF, CC, 50V, 5%, 0603	150F-103J+P-AC	4
C226	0.01uF, CC, 50V, 5%, 0603	150F-103J+P-AC	4
C231	10uF, CE, 16V, 20%, RLT, 4X7, ELNA	157D-106M+K-GME	4
C233	0.1uF, CC, 50V, 5%, 0603	150F-104J+P-AC	4
C235	0.1uF, CC, 50V, 5%, 0603	150F-104J+P-AC	4
C236	1000pF, CC, 50V, 5%, 0603, X7R	150F-102J+P-AC	4
C237	0.1uF, CC, 50V, 5%, 0603	150F-104J+P-AC	4
C238	100pF, CC, 50V, 5%, 0603/1608, 1X2	150F-101J+P-AC	4
C239	1000pF, CC, 50V, 5%, 0603, X7R	150F-102J+P-AC	4

Electrical Part List

Input/Output PCB Assembly

Capacitors (continued)

Reference Designator	Description	Vendor Part Number	Note
C240	10uF, CE, 16V, 20%, RLT, 4X7, ELNA	157D-106M+K-GME	4
C242	0.1uF, CC, 50V, 5%, 0603	150F-104J+P-AC	4
C243	10uF, CE, 16V, 20%, RLT, 4X7, ELNA	157D-106M+K-GME	4
C244	10uF, CE, 16V, 20%, RLT, 4X7, ELNA	157D-106M+K-GME	4
C245	0.1uF, CC, 50V, 5%, 0603	150F-104J+P-AC	4
C250	0.1uF, CC, 50V, 5%, 0603	150F-104J+P-AC	4
C251	0.1uF, CC, 50V, 5%, 0603	150F-104J+P-AC	4
C253	0.047uF, CC, 50V, 5%, 0603, 0.8X1.6	150F-473J+P-AC	4
C254	0.047uF, CC, 50V, 5%, 0603, 0.8X1.6	150F-473J+P-AC	4
C255	0.01uF, CC, 50V, 5%, 0603	150F-103J+P-AC	4
C256	0.01uF, CC, 50V, 5%, 0603	150F-103J+P-AC	4
C258	1000pF, CC, 50V, 5%, 0603, X7R	150F-102J+P-AC	4
C259	3300pF, CC, 50V, 5%, 0603, (0.8X1.6)	150F-332J+P-AC	4
C260	1uF, CE, 50V, 20%, RLT, 4X7, ELNA	157F-105M+K-GME	4
C300	0.1uF, CC, 50V, 5%, 0603	150F-104J+P-AC	4
C301	10uF, CE, 50V, 20%, RLT, 5X11	157F-106M+K-IU	4
C302	10uF, CE, 16V, 20%, RLT, 4X7, ELNA	157D-106M+K-GME	4
C303	0.1uF, CC, 50V, 5%, 0603	150F-104J+P-AC	4
C306	10uF, CE, 16V, 20%, RLT, 4X7, ELNA	157D-106M+K-GME	4
C308	0.1uF, CC, 50V, 5%, 0603	150F-104J+P-AC	4
C309	1000pF, CC, 50V, 5%, 0603, X7R	150F-102J+P-AC	4
C310	47uF, CE, 25V, 20%, RLT, 5X11, ELNA	157E-476M+K-IUE	4
C311	47uF, CE, 25V, 20%, RLT, 5X11, ELNA	157E-476M+K-IUE	4
C312	4700pF, CC, 50V, 5%, 0603, 0.8X1.6	150F-472J+P-AC	4
C313	68pF, CC, 50V, 5%, 0603, 0.8X1.6	150F-680J+P-AC	4
C314	68pF, CC, 50V, 5%, 0603, 0.8X1.6	150F-680J+P-AC	4
C315	0.1uF, CC, 50V, 5%, 0603	150F-104J+P-AC	4
C316	0.1uF, CC, 50V, 5%, 0603	150F-104J+P-AC	4
C317	0.1uF, CC, 50V, 5%, 0603	150F-104J+P-AC	4
C318	0.1uF, CC, 50V, 5%, 0603	150F-104J+P-AC	4
C319	0.1uF, CC, 50V, 5%, 0603	150F-104J+P-AC	4
C320	0.1uF, CC, 50V, 5%, 0603	150F-104J+P-AC	4
C321	0.1uF, CC, 50V, 5%, 0603	150F-104J+P-AC	4
C322	0.1uF, CC, 50V, 5%, 0603	150F-104J+P-AC	4
C323	0.1uF, CC, 50V, 5%, 0603	150F-104J+P-AC	4
C324	0.1uF, CC, 50V, 5%, 0603	150F-104J+P-AC	4
C325	10uF, CE, 16V, 20%, RLT, 4X7, ELNA	157D-106M+K-GME	4
C326	0.1uF, CC, 50V, 5%, 0603	150F-104J+P-AC	4
C327	47uF, CE, 25V, 20%, RLT, 5X11, ELNA	157E-476M+K-IUE	4
C328	47uF, CE, 25V, 20%, RLT, 5X11, ELNA	157E-476M+K-IUE	4
C329	0.1uF, CC, 50V, 5%, 0603	150F-104J+P-AC	4
C330	0.1uF, CC, 50V, 5%, 0603	150F-104J+P-AC	4
C331	0.1uF, CC, 50V, 5%, 0603	150F-104J+P-AC	4
C332	0.1uF, CC, 50V, 5%, 0603	150F-104J+P-AC	4
C333	0.1uF, CC, 50V, 5%, 0603	150F-104J+P-AC	4
C334	0.1uF, CC, 50V, 5%, 0603	150F-104J+P-AC	4
C335	0.1uF, CC, 50V, 5%, 0603	150F-104J+P-AC	4
C336	0.1uF, CC, 50V, 5%, 0603	150F-104J+P-AC	4

Electrical Part List

Input/Output PCB Assembly

Capacitors (continued)

Reference Designator	Description	Vendor Part Number	Note
C337	0.1F, CC, 25V, 10%, 0603, X7R	150E-104K+P-AC	4
C338	0.1F, CC, 25V, 10%, 0603, X7R	150E-104K+P-AC	4
C339	0.047uF, CC, 50V, 5%, 0603, 0.8X1.6	150F-473J+P-AC	4
C340	0.1uF, CC, 50V, 5%, 0603	150F-104J+P-AC	4
C341	0.1uF, CC, 50V, 5%, 0603	150F-104J+P-AC	4
C342	4700pF, CC, 50V, 5%, 0603, 0.8X1.6	150F-472J+P-AC	4
C345	0.1uF, CC, 50V, 5%, 0603	150F-104J+P-AC	4
C346	0.1uF, CC, 50V, 5%, 0603	150F-104J+P-AC	4
C347	0.1uF, CC, 50V, 5%, 0603	150F-104J+P-AC	4
C348	0.1uF, CC, 50V, 5%, 0603	150F-104J+P-AC	4
C349	100pF, CC, 50V, 5%, 0603/1608, 1X2	150F-101J+P-AC	4
C350	100pF, CC, 50V, 5%, 0603/1608, 1X2	150F-101J+P-AC	4
C352	1000pF, CC, 50V, 5%, 0603, X7R	150F-102J+P-AC	4
C353	1000pF, CC, 50V, 5%, 0603, X7R	150F-102J+P-AC	4
C354	1000pF, CC, 50V, 5%, 0603, X7R	150F-102J+P-AC	4
C355	1000pF, CC, 50V, 5%, 0603, X7R	150F-102J+P-AC	4
C356	1000pF, CC, 50V, 5%, 0603, X7R	150F-102J+P-AC	4
C360	1000pF, CC, 50V, 5%, 0603, X7R	150F-102J+P-AC	4
C363	0.01uF, CC, 50V, 5%, 0603	150F-103J+P-AC	4
C364	0.01uF, CC, 50V, 5%, 0603	150F-103J+P-AC	4
C365	0.1uF, CC, 50V, 5%, 0603	150F-104J+P-AC	4
C366	0.1uF, CC, 50V, 5%, 0603	150F-104J+P-AC	4
C367	100pF, CC, 50V, 5%, 0603/1608, 1X2	150F-101J+P-AC	4
C368	0.1uF, CC, 50V, 5%, 0603	150F-104J+P-AC	4
C369	100pF, CC, 50V, 5%, 0603/1608, 1X2	150F-101J+P-AC	4
C370	100pF, CC, 50V, 5%, 0603/1608, 1X2	150F-101J+P-AC	4
C371	100pF, CC, 50V, 5%, 0603/1608, 1X2	150F-101J+P-AC	4
C372	100pF, CC, 50V, 5%, 0603/1608, 1X2	150F-101J+P-AC	4
C373	100pF, CC, 50V, 5%, 0603/1608, 1X2	150F-101J+P-AC	4
C374	0.01uF, CC, 50V, 5%, 0603	150F-103J+P-AC	4
C375	0.01uF, CC, 50V, 5%, 0603	150F-103J+P-AC	4
C376	0.01uF, CC, 50V, 5%, 0603	150F-103J+P-AC	4
C377	0.01uF, CC, 50V, 5%, 0603	150F-103J+P-AC	4
C378	0.047uF, CC, 50V, 5%, 0603, 0.8X1.6	150F-473J+P-AC	4
C383	10uF, CE, 16V, 20%, RLT, 4X7, ELNA	157D-106M+K-GME	4
C386	10uF, CE, 16V, 20%, RLT, 4X7, ELNA	157D-106M+K-GME	4
C387	0.022uF, CC, 50V, 10%, 0603	150F-223K+P-AC	4
C388	0.022uF, CC, 50V, 10%, 0603	150F-223K+P-AC	4
C389	0.01uF, CC, 50V, 5%, 0603	150F-103J+P-AC	4
C390	0.01uF, CC, 50V, 5%, 0603	150F-103J+P-AC	4
C397	0.1uF, CC, 50V, 5%, 0603	150F-104J+P-AC	4
C400	0.1uF, CC, 50V, 5%, 0603	150F-104J+P-AC	4
C401	0.047uF, CC, 50V, 5%, 0603, 0.8X1.6	150F-473J+P-AC	4
C402	47uF, CE, 25V, 20%, RLT, 5X11, ELNA	157E-476M+K-IUE	4
C403	0.1uF, CC, 50V, 5%, 0603	150F-104J+P-AC	4
C404	0.1uF, CC, 50V, 5%, 0603	150F-104J+P-AC	4
C405	0.1uF, CC, 50V, 5%, 0603	150F-104J+P-AC	4
C406	0.047uF, CC, 50V, 5%, 0603, 0.8X1.6	150F-473J+P-AC	4

Electrical Part List

Input/Output PCB Assembly

Capacitors (continued)

Reference Designator	Description	Vendor Part Number	Note
C407	0.1uF, CC, 50V, 5%, 0603	150F-104J+P-AC	4
C408	0.1uF, CC, 50V, 5%, 0603	150F-104J+P-AC	4
C409	1000pF, CC, 50V, 5%, 0603, X7R	150F-102J+P-AC	4
C410	1000pF, CC, 50V, 5%, 0603, X7R	150F-102J+P-AC	4
C411	100pF, CC, 50V, 5%, 0603/1608, 1X2	150F-101J+P-AC	4
C415	0.1uF, CC, 50V, 5%, 0603	150F-104J+P-AC	4
C416	0.01uF, CC, 50V, 5%, 0603	150F-103J+P-AC	4
C417	0.01uF, CC, 50V, 5%, 0603	150F-103J+P-AC	4
C418	0.1uF, CC, 50V, 5%, 0603	150F-104J+P-AC	4
C419	0.1uF, CC, 50V, 5%, 0603	150F-104J+P-AC	4
C422	68pF, CC, 50V, 5%, 0603, 0.8X1.6	150F-680J+P-AC	4
C424	0.047uF, CC, 50V, 5%, 0603, 0.8X1.6	150F-473J+P-AC	4
C425	0.01uF, CC, 50V, 5%, 0603	150F-103J+P-AC	4
C426	0.027uF, CC, 50V, 5%, 0603, 0.8X1.6	150F-273J+P-AC	4
C427	0.01uF, CC, 50V, 5%, 0603	150F-103J+P-AC	4
C428	0.027uF, CC, 50V, 5%, 0603, 0.8X1.6	150F-273J+P-AC	4
C434	0.1uF, CC, 50V, 5%, 0603	150F-104J+P-AC	4
C435	0.1uF, CC, 50V, 5%, 0603	150F-104J+P-AC	4
C436	100uF, CE, 25V, 20%, RLT, 6.3X11, 105C, LOW ESR	157E-107M+K-LURT	4
C437	100uF, CE, 25V, 20%, RLT, 6.3X11, 105C, LOW ESR	157E-107M+K-LURT	4
C438	0.1uF, CC, 50V, 5%, 0603	150F-104J+P-AC	4
C439	0.1uF, CC, 50V, 5%, 0603	150F-104J+P-AC	4
C440	0.1uF, CC, 50V, 5%, 0603	150F-104J+P-AC	4
C441	0.1uF, CC, 50V, 5%, 0603	150F-104J+P-AC	4
C442	10uF, CE, 50V, 20%, RLT, 5X11	157F-106M+K-IU	4
C444	0.1uF, CC, 50V, 5%, 0603	150F-104J+P-AC	4
C445	0.1uF, CC, 50V, 5%, 0603	150F-104J+P-AC	4
C446	100pF, CC, 50V, 5%, 0603/1608, 1X2	150F-101J+P-AC	4
C448	100pF, CC, 50V, 5%, 0603/1608, 1X2	150F-101J+P-AC	4
C451	0.1uF, CC, 50V, 5%, 0603	150F-104J+P-AC	4
C452	0.1uF, CC, 50V, 5%, 0603	150F-104J+P-AC	4
C453	0.1uF, CC, 50V, 5%, 0603	150F-104J+P-AC	4
C454	0.1uF, CC, 50V, 5%, 0603	150F-104J+P-AC	4
C500	100pF, CC, 50V, 5%, 0603/1608, 1X2	150F-101J+P-AC	4
C501	0.1uF, CC, 50V, 5%, 0603	150F-104J+P-AC	4
C502	0.1uF, CC, 50V, 5%, 0603	150F-104J+P-AC	4
C503	0.1uF, CC, 50V, 5%, 0603	150F-104J+P-AC	4
C504	0.1uF, CC, 50V, 5%, 0603	150F-104J+P-AC	4
C505	0.1uF, CC, 50V, 5%, 0603	150F-104J+P-AC	4
C506	0.1uF, CC, 50V, 5%, 0603	150F-104J+P-AC	4
C507	0.1uF, CC, 50V, 5%, 0603	150F-104J+P-AC	4
C508	0.1uF, CC, 50V, 5%, 0603	150F-104J+P-AC	4
C509	0.1uF, CC, 50V, 5%, 0603	150F-104J+P-AC	4
C510	0.1uF, CC, 50V, 5%, 0603	150F-104J+P-AC	4
C511	0.1uF, CC, 50V, 5%, 0603	150F-104J+P-AC	4
C512	0.1uF, CC, 50V, 5%, 0603	150F-104J+P-AC	4
C513	0.1uF, CC, 50V, 5%, 0603	150F-104J+P-AC	4

Electrical Part List

Input/Output PCB Assembly
Capacitors (continued)

Reference Designator	Description	Vendor Part Number	Note
C515	0.1uF, CC, 50V, 5%, 0603	150F-104J+P-AC	4
C518	0.1uF, CC, 50V, 5%, 0603	150F-104J+P-AC	4
C519	0.1uF, CC, 50V, 5%, 0603	150F-104J+P-AC	4
C520	47uF, CE, 16V, 20%, RLT, 5X7	157D-476M+K-IME	4
C521	47uF, CE, 16V, 20%, RLT, 5X7	157D-476M+K-IME	4
C522	0.047uF, CC, 50V, 5%, 0603, 0.8X1.6	150F-473J+P-AC	4
C523	68pF, CC, 50V, 5%, 0603, 0.8X1.6	150F-680J+P-AC	4
C524	0.1uF, CC, 50V, 5%, 0603	150F-104J+P-AC	4

Inductors

Reference Designator	Description	Vendor Part Number	Note
L300	FERRITE BEAD, SMD, ACB453215, 125 OHM	1802-0630+0	4
L301	FERRITE BEAD, SMD, ACB453215, 125 OHM	1802-0630+0	4

Diodes

Reference Designator	Description	Vendor Part Number	Note
D100	DIODE, BAV99, SOT23, PHILIPS	4840-8970+3	4
D101	DIODE, BAV99, SOT23, PHILIPS	4840-8970+3	4
D102	LED, SMD, 1.6X0.8X0.75, GN, HIGH, 525NM, KINGBRIGHT	3700-7851+G	4
D103	LED, SMD, 1.6X0.8X0.75, GN, HIGH, 525NM, KINGBRIGHT	3700-7851+G	4
D104	DIODE, 1SS355TE-17, ROHM	4840-1660+0	4
D105	DIODE, 1SS355TE-17, ROHM	4840-1660+0	4
D106	ZENER, 0.2W, UDZS5.1B, ROHM, SM	483H-5V11+3	4
D107	LOW CURRENT SMD LED, RED 2mA	3700-7829+R	4
D108	LOW CURRENT SMD LED, RED 2mA	3700-7829+R	4
D109	ZENER, 0.2W, UDZS5.1B, ROHM, SM	483H-5V11+3	4
D110	ZENER, 0.2W, UDZS5.1B, ROHM, SM	483H-5V11+3	4
D202	DIODE, BAV99, SOT23, PHILIPS	4840-8970+3	4
D203	DIODE, BAV99, SOT23, PHILIPS	4840-8970+3	4
D204	LED, SMD, 1.6X0.8X0.75, GN, HIGH, 525NM, KINGBRIGHT	3700-7851+G	4
D205	LED, SMD, 1.6X0.8X0.75, GN, HIGH, 525NM, KINGBRIGHT	3700-7851+G	4
D206	DIODE, 1SS355TE-17, ROHM	4840-1660+0	4
D207	DIODE, 1SS355TE-17, ROHM	4840-1660+0	4
D208	ZENER, 0.2W, UDZS5.1B, ROHM, SM	483H-5V11+3	4
D209	LOW CURRENT SMD LED, RED 2mA	3700-7829+R	4
D210	LOW CURRENT SMD LED, RED 2mA	3700-7829+R	4
D300	LED, SMD, 1.6X0.8X0.6, 469NM, BL, WAVELENGTH464NM-476NM	3700-7848+B	4
D301	LED, SMD, 1.6X0.8X0.6, 469NM, BL, WAVELENGTH464NM-476NM	3700-7848+B	4
D302	DIODE, BAV99, SOT23, PHILIPS	4840-8970+3	4
D303	DIODE, BAV99, SOT23, PHILIPS	4840-8970+3	4

Electrical Part List

Input/Output PCB Assembly

Diodes (continued)

Reference Designator	Description	Vendor Part Number	Note
D304	DIODE, BAV99, SOT23, PHILIPS	4840-8970+3	4
D305	DIODE, BAV99, SOT23, PHILIPS	4840-8970+3	4
D306	DIODE, BAV99, SOT23, PHILIPS	4840-8970+3	4
D401	DIODE, BAV99, SOT23, PHILIPS	4840-8970+3	4
D402	DIODE, BAV99, SOT23, PHILIPS	4840-8970+3	4
D500	DIODE, 1SS355TE-17, ROHM	4840-1660+0	4
D501	DIODE, 1SS355TE-17, ROHM	4840-1660+0	4
D502	DIODE, 1SS355TE-17, ROHM	4840-1660+0	4
D503	DIODE, 1SS355TE-17, ROHM	4840-1660+0	4
D504	DIODE, 1SS355TE-17, ROHM	4840-1660+0	4
D505	DIODE, 1SS355TE-17, ROHM	4840-1660+0	4
D506	DIODE, 1SS355TE-17, ROHM	4840-1660+0	4
D507	DIODE, 1SS355TE-17, ROHM	4840-1660+0	4
D508	DIODE, 1SS355TE-17, ROHM	4840-1660+0	4
D509	DIODE, 1SS355TE-17, ROHM	4840-1660+0	4
D510	ZENER, 1/2W, 5.1V, MMSZ5231B, SOD-123, SMD, PANJIT	4837-5V18+3	4
D512	ZENER, 1/2W, 5.1V, MMSZ5231B, SOD-123, SMD, PANJIT	4837-5V18+3	4

Transistors

Reference Designator	Description	Vendor Part Number	Note
Q100	MMBT4403LT1G, SMD	4854-4030+3	4
Q101	MMBT4403LT1G, SMD	4854-4030+3	4
Q102	MMBT4403LT1G, SMD	4854-4030+3	4
Q103	MMBT4403LT1G, SMD	4854-4030+3	4
Q104	MMBT4403LT1G, SMD	4854-4030+3	4
Q105	MMBT4403LT1G, SMD	4854-4030+3	4
Q106	MMBT4403LT1G, SMD	4854-4030+3	4
Q107	MMBT4403LT1G, SMD	4854-4030+3	4
Q108	NPN, MMBT4401, SOT-23, HFE:20-300, SM	4854-4010+3	4
Q109	NPN, MMBT4401, SOT-23, HFE:20-300, SM	4854-4010+3	4
Q110	2N2222, SMD, MMBT2222ALT1G	4860-5410+3	4
Q112	2N2222, SMD, MMBT2222ALT1G	4860-5410+3	4
Q200	2N2222, SMD, MMBT2222ALT1G	4860-5410+3	4
Q202	2N2222, SMD, MMBT2222ALT1G	4860-5410+3	4

Electrical Part List

Input/Output PCB Assembly

Integrated Circuits

Reference Designator	Description	Vendor Part Number	Note
U100	NJM2068M-#ZZZB, DUAL OP AMP	3130-6890+0	4
U101	TL072CDR, DUAL J-FET INPUT, OP-AMP	3130-8020+0	4
U102	TL072CDR, DUAL J-FET INPUT, OP-AMP	3130-8020+0	4
U103	TL072CDR, DUAL J-FET INPUT, OP-AMP	3130-8020+0	4
U104	TL072CDR, DUAL J-FET INPUT, OP-AMP	3130-8020+0	4
U106	TL072CDR, DUAL J-FET INPUT, OP-AMP	3130-8020+0	4
U107	TL072CDR, DUAL J-FET INPUT, OP-AMP	3130-8020+0	4
U200	TL072CDR, DUAL J-FET INPUT, OP-AMP	3130-8020+0	4
U201	TL072CDR, DUAL J-FET INPUT, OP-AMP	3130-8020+0	4
U202	TL072CDR, DUAL J-FET INPUT, OP-AMP	3130-8020+0	4
U204	TL072CDR, DUAL J-FET INPUT, OP-AMP	3130-8020+0	4
U205	TL072CDR, DUAL J-FET INPUT, OP-AMP	3130-8020+0	4
U206	TL072CDR, DUAL J-FET INPUT, OP-AMP	3130-8020+0	4
U207	OP AMP SWITCH, NJM2120M, SOIC8, JRC	3132-3711+0	4
U300	TL072CDR, DUAL J-FET INPUT, OP-AMP	3130-8020+0	4
U301	TL072CDR, DUAL J-FET INPUT, OP-AMP	3130-8020+0	4
U302	TL072CDR, DUAL J-FET INPUT, OP-AMP	3130-8020+0	4
U303	TL072CDR, DUAL J-FET INPUT, OP-AMP	3130-8020+0	4
U304	TL072CDR, DUAL J-FET INPUT, OP-AMP	3130-8020+0	4
U305	TL072CDR, DUAL J-FET INPUT, OP-AMP	3130-8020+0	4
U306	TL072CDR, DUAL J-FET INPUT, OP-AMP	3130-8020+0	4
U307	TL072CDR, DUAL J-FET INPUT, OP-AMP	3130-8020+0	4
U308	TL072CDR, DUAL J-FET INPUT, OP-AMP	3130-8020+0	4
U309	TL072CDR, DUAL J-FET INPUT, OP-AMP	3130-8020+0	4
U310	TL072CDR, DUAL J-FET INPUT, OP-AMP	3130-8020+0	4
U312	TL072CDR, DUAL J-FET INPUT, OP-AMP	3130-8020+0	4
U313	TL072CDR, DUAL J-FET INPUT, OP-AMP	3130-8020+0	4
U314	LM13700M/NOPB, TRANSCOND. AMP	3132-1981+0	4
U315	VOLT REG, +15V, L7815ACD2T, D2PAK, ST	3132-3881+0	4
U316	VOLT REG, -15V, L7915CD2T, D2PAK, ST	3132-3891+0	4
U317	TL072CDR, DUAL J-FET INPUT, OP-AMP	3130-8020+0	4
U391	TL072CDR, DUAL J-FET INPUT, OP-AMP	3130-8020+0	4
U500	TL072CDR, DUAL J-FET INPUT, OP-AMP	3130-8020+0	4
U501	TL072CDR, DUAL J-FET INPUT, OP-AMP	3130-8020+0	4
U502	TL072CDR, DUAL J-FET INPUT, OP-AMP	3130-8020+0	4

Electrical Part List

Input/Output PCB Assembly

Miscellaneous

Reference Designator	Description	Vendor Part Number	Note
CN300A	WAFER, 10 PIN, P2	2102-100S+003	4
CN302A	WIRE-CONN, 10P, P2.0, #26, UL2468, L=110, F/M	7012-7033+0	4
CN308A	CONNECTOR, 5 PIN, P2.5 (JST 05JQ-BT)	2101-1371+0	4
J100	XLR, FEMALE CONN, NC3FAV1-0 (BOSE PART NUMBER 317377-000S)	2113-1337+1	
J200	JACK, RCA, 2P, UPRIGHT, W/R, SILVER (BOSE PART NUMBER 317378-000S)	2113-3131+1	
J202	JACK, PHONE, 5P, 6.4MM, BLACK, W/SW (BOSE PART NUMBER 317380-000S)	2113-3269+0	
SW200	SWITCH, SLIDE, DPDT, 50V, 0.3A, L=12, 16X6.5X8	5200-4984+0	4
VR100	POT, VOLUME CONTROL, MIC INPUT (BOSE PART NUMBER 317375-000S)	4751-1849+0	
VR101	POT, BASS/TREBLE (BOSE PART NUMBER 317376-000S)	4750-9655+0	
VR102	POT, BASS/TREBLE (BOSE PART NUMBER 317376-000S)	4750-9655+0	
VR200	POT, VOLUME CONTROL, CH 2, (BOSE PART NUMBER 317374-000S)	4751-0750+0	

3.5mm Line Input PCB Assembly

Miscellaneous

Reference Designator	Description	Vendor Part Number	Note
CN308B	WAFER, 5P, P2.5, RA, M, S5B-XH-A	2101-3255+0	4
J801	JACK, PHONE, 3.5MM, STEREO, 3P (BOSE PART NUMBER 319969-000S)	2113-3335+0	4

Output PCB Assembly

Resistors

Reference Designator	Description	Vendor Part Number	Note
R330	330 OHM, RMG, 1/16W, 1%, 0603	4723-331A+P	4
R331	330 OHM, RMG, 1/16W, 1%, 0603	4723-331A+P	4
R454	330 OHM, RMG, 1/16W, 1%, 0603	4723-331A+P	4
R455	100 OHM, RMG, 1/16W, 1%, 0603	4723-101A+P	4
R801	6.8K, RMG, 1/16W, 1%, 0603/1608	4723-682A+P	4
R802	6.8K, RMG, 1/16W, 1%, 0603/1608	4723-682A+P	4

Electrical Part List

Output PCB Assembly

Capacitors

Reference Designator	Description	Vendor Part Number	Note
C351	1000pF, CC, 50V, 5%, 0603, X7R	150F-102J+P-AC	4
C361	100pF, CC, 50V, 5%, 0603/1608, 1X2	150F-101J+P-AC	4
C362	100pF, CC, 50V, 5%, 0603/1608, 1X2	150F-101J+P-AC	4
C447	1000pF, CC, 50V, 5%, 0603, X7R	150F-102J+P-AC	4
C449	100pF, CC, 50V, 5%, 0603/1608, 1X2	150F-101J+P-AC	4
C450	100pF, CC, 50V, 5%, 0603/1608, 1X2	150F-101J+P-AC	4
C701	100pF, CC, 50V, 5%, 0603/1608, 1X2	150F-101J+P-AC	4
C702	100pF, CC, 50V, 5%, 0603/1608, 1X2	150F-101J+P-AC	4
C801	0.1uF, CC, 50V, 5%, 0603	150F-104J+P-AC	4
C802	1000pF, CC, 50V, 5%, 0603, X7R	150F-102J+P-AC	4
C803	1000pF, CC, 50V, 5%, 0603, X7R	150F-102J+P-AC	4
C804	0.1uF, CC, 50V, 5%, 0603	150F-104J+P-AC	4

Miscellaneous

Reference Designator	Description	Vendor Part Number	Note
CN302B	WAFER, 10 PIN, P2	2102-100S+003	4
J300	JACK, RCA, 2P, W/R, SILVER	2113-1801+2	4
J301	JACK, SOCKET, NRJ6HF (STEREO)	2113-3085+0	4

Electrical Part List

Power Amplifier PCB Assembly

Resistors

Reference Designator	Description	Vendor Part Number	Note
R1	110K, RMG, 1/4W, 5%, 1206	4725-114J+6	4
R2	10 OHM, RMG, 1/8W, 1%, 1206	4721-100A+6	4
R3	49.9 OHM, RMG, 1/4W, 1%, 1206	4725-49R9+6	4
R4	20 OHM, RMG, 1/4W, 1%, 1206	4725-200A+6	4
R5	1M, RMG, 1/16W, 1%, 0603	4723-105A+P	4
R6	1M, RMG, 1/16W, 1%, 0603	4723-105A+P	4
R7	820K, RMG, 1/8W, 5%, 1206	4721-824J+6	4
R8	820K, RMG, 1/8W, 5%, 1206	4721-824J+6	4
R9	820K, RMG, 1/8W, 5%, 1206	4721-824J+6	4
R10	820K, RMG, 1/8W, 5%, 1206	4721-824J+6	4
R11	820K, RMG, 1/8W, 5%, 1206	4721-824J+6	4
R12	2M, RMG, 1/4W, 1%, 1206	4725-205A+6	4
R13	1.8M, RMG, 1/8W, 1%, 1206	4721-185A+6	4
R14	820K, RMG, 1/8W, 5%, 1206	4721-824J+6	4
R15	820K, RMG, 1/8W, 5%, 1206	4721-824J+6	4
R16	0 OHM, RMG, 1/16W, 1%, 0603	4723-000A+P	4
R18	6.8 OHM, RMG, 1/16W, 1%, 0603	4723-6R8A+P	4
R19	1K, RMG, 1/10W, 1%, 0805	4720-102A+J	4
R20	0 OHM, RMG, 1/16W, 1%, 0603	4723-000A+P	4
R21	22 OHM, RMG, 1W, 5%, 2512	4728-220J+3	4
R22	22 OHM, RMG, 1W, 5%, 2512	4728-220J+3	4
R23	10 OHM, RMG, 1/4W, 5%, 1206	4725-100J+6	4
R24	10 OHM, RMG, 1/4W, 5%, 1206	4725-100J+6	4
R25	10K, RMG, 1/16W, 1%, 0603/1608	4723-103A+P	4
R26	20K, RMG, 1/16W, 1%, 0603/1608	4723-203A+P	4
R27	180 OHM, RMG, 1/16W, 1%, 0603/1608	4723-181A+P	4
R28	100K, RMG, 1/16W, 1%, 0603	4723-104A+P	4
R29	16 OHM, RMG, 1/4W, 1%, 1206	4725-160A+6	4
R30	3.3K, RMG, 1/16W, 1%, 0603/1608	4723-332A+P	4
R31	1K, RMG, 1/16W, 1%, 0603/1608	4723-102A+P	4
R32	402K, RMG, 1/16W, 1%, 0603	4723-4023+P	4
R33	10 OHM, RMG, 1/4W, 5%, 1206	4725-100J+6	4
R34	24 OHM, RMG, 1/4W, 1%, 1206	4725-240A+6	4
R35	24 OHM, RMG, 1/4W, 1%, 1206	4725-240A+6	4
R36	49.9 OHM, RMG, 1/4W, 1%, 1206	4725-49R9+6	4
R37	49.9 OHM, RMG, 1/4W, 1%, 1206	4725-49R9+6	4
R38	210K, RMG, 1/16W, 1%, 0603	4723-214A+P	4
R39	16 OHM, RMG, 1/4W, 1%, 1206	4725-160A+6	4
R40	4.7K, RMG, 1/16W, 1%, 0603/1608	4723-472A+P	4
R41	49.9 OHM, RMG, 1/4W, 1%, 1206	4725-49R9+6	4
R42	49.9 OHM, RMG, 1/4W, 1%, 1206	4725-49R9+6	4
R43	4.7K, RMG, 1/16W, 1%, 0603/1608	4723-472A+P	4
R44	10 OHM, RMG, 1/4W, 5%, 1206	4725-100J+6	4
R45	20K, RMG, 1/16W, 1%, 0603/1608	4723-203A+P	4
R46	5.6K, RMG, 1/16W, 1%, 0603/1608	4723-562A+P	4
R47	39K, RMG, 1/10W, 1%, 0603	4720-393A+P	4

Electrical Part List

Power Amplifier PCB Assembly

Resistors (continued)

Reference Designator	Description	Vendor Part Number	Note
R48	20K, RMG, 1/16W, 1%, 0603/1608	4723-203A+P	4
R49	5.6K, RMG, 1/16W, 1%, 0603/1608	4723-562A+P	4
R50	39K, RMG, 1/16W, 5%, 0603	4723-393J+P-R	4
R51	100K, RMG, 1/16W, 1%, 0603	4723-104A+P-R	4
R52	5.6K, RMG, 1/16W, 1%, 0603/1608	4723-562A+P	4
R53	39K, RMG, 1/10W, 1%, 0603	4720-393A+P	4
R54	100 OHM, RMG, 1/16W, 1%, 0603	4723-101A+P	4
R55	30K, RMG, 1/16W, 1%, 0603/1608	4723-303A+P	4
R56	5.6K, RMG, 1/16W, 1%, 0603/1608	4723-562A+P	4
R57	20K, RMG, 1/16W, 1%, 0603/1608	4723-203A+P	4
R58	4.7K, RMG, 1/16W, 1%, 0603/1608	4723-472A+P	4
R59	100K, RMG, 1/16W, 1%, 0603	4723-104A+P	4
R60	820K, RMG, 1/8W, 5%, 1206	4721-824J+6	4
R62	20 OHM, RMG, 1/4W, 1%, 1206	4725-200A+6	4
R63	4.7K, RMG, 1/16W, 1%, 0603/1608	4723-472A+P	4
R66	10K, RMG, 1/16W, 1%, 0603/1608	4723-103A+P	4
R100	0 OHM, RMG, 1/4W, 5%, 1206	4725-000J+6	4
R535	10K, RMG, 1/16W, 1%, 0603/1608	4723-103A+P	4
R538	4.7K, RMG, 1/16W, 1%, 0603/1608	4723-472A+P	4

Capacitors

Reference Designator	Description	Vendor Part Number	Note
C1	470uF, CE, 250V, 20%, RL, 25X40, 105C	157R-477M+5-&^T	4
C2	3300pF, CC, 1000V, 10%, RLT, 10X4, X7R, 125C	150N-332K+K-SG	4
C3	470uF, CE, 250V, 20%, RL, 25X40, 105C	157R-477M+5-&^T	4
C4	47uF, CE, 10V, 20%, RLT, 5X11, 105C	157C-476M+K-IUT	4
C5	4.7uF, CE, 63V, 20%, RLT, 5X11, LOW ESR, 105C	157I-475M+K-IURT	4
C6	0.1uF, CC, 100V, 10%, 1206, AVX	150H-104K+6-CFD	4
C7	2200pF, CC, 1000V, 10%, RLT, 6X3, X7R, 125C	150N-222K+K-KE	4
C8	0.68uF, CM, 100V, 5%, RBT, 7.5X11.5, MKS2, WIMA	153H-684J+V-NVU	4
C9	0.68uF, CM, 100V, 5%, RBT, 7.5X11.5, MKS2, WIMA	153H-684J+V-NVU	4
C10	0.1uF, CC, 50V, 5%, 0805, 1.25X2	150F-104J+J-BD	4
C11	0.01uF, CC, 50V, 5%, 0603	150F-103J+P-AC	4
C12	1000uF, CE, 35V, 20%, RLT, 12.5X25, 105C, LOW ESR	157Q-108M+K-X&TR	4
C13	220pF, CC, 50V, 5%, 0603	150F-221J+P-AC	4
C14	220pF, CC, 50V, 5%, 0603	150F-221J+P-AC	4
C15	47uF, CE, 100V, 20%, RLT10X16, LOW ESR, 105C	157H-476M+K-S5RT	4
C16	470uF, CE, 35V, 20%, RLT, 10X20, 105C, LOW ESR	157Q-477M+K-S9RT	4
C17	470uF, CE, 35V, 20%, RLT, 10X20, 105C, LOW ESR	157Q-477M+K-S9RT	4

Electrical Part List

Power Amplifier PCB Assembly

Capacitors (continued)

Reference Designator	Description	Vendor Part Number	Note
C18	1000uF, CE, 35V, 20%, RLT, 12.5X25, 105C, LOW ESR	157Q-108M+K-X&TR	4
C19	0.01uF, CC, 50V, 5%, 0603	150F-103J+P-AC	4
C20	1000pF, CC, 1000V, 10%, RLT, 6X3, 125C, X7R	1511-102K+K-0N	4
C21	1000pF, CC, 1000V, 10%, RLT, 6X3, 125C, X7R	1511-102K+K-0N	4
C22	0.015uF, CC, 50V, 10%, 0603	150F-153K+P-AC	4
C23	0.015uF, CC, 50V, 10%, 0603	150F-153K+P-AC	4
C24	0.1uF, CC, 50V, 10%, 0805, 1.2X2.0	150F-104K+J-BD	4
C25	0.1uF, CC, 100V, 10%, RLT, 5X5, X7R	150H-104K+K-II	4
C26	0.1uF, CC, 100V, 10%, RLT, 5X5, X7R	150H-104K+K-II	4
C27	10uF, CE, 50V, 20%, RLT, 5X11, 105C	157F-106M+K-IUTI	4
C28	1000pF, CC, 50V, 5%, 0603, X7R	150F-102J+P-AC	4
C29	1000uF, CE, 35V, 20%, RLT, 12.5X25, 105C, LOW ESR	157Q-108M+K-X&TR	4
C30	1000uF, CE, 35V, 20%, RLT, 12.5X25, 105C, LOW ESR	157Q-108M+K-X&TR	4
C31	0.1uF, CC, 50V, 10%, 0805, 1.2X2.0	150F-104K+J-BD	4
C32	1000pF, CC, 50V, 5%, 0603, X7R	150F-102J+P-AC	4
C33	1000uF, CE, 35V, 20%, RLT, 12.5X25, 105C, LOW ESR	157Q-108M+K-X&TR	4
C34	100uF, CE, 35V, 20%, RLT, 6.3X11, 105C, LOW ESR	157Q-107M+K-LUTR	4
C35	1000uF, CE, 35V, 20%, RLT, 12.5X25, 105C, LOW ESR	157Q-108M+K-X&TR	4
C36	0.1uF, CC, 50V, 10%, 0805, 1.2X2.0	150F-104K+J-BD	4
C37	1000pF, CC, 50V, 5%, 0603, X7R	150F-102J+P-AC	4
C38	100uF, CE, 35V, 20%, RLT, 6.3X11, 105C, LOW ESR	157Q-107M+K-LUTR	4
C39	1000pF, CC, 50V, 5%, 0603, X7R	150F-102J+P-AC	4
C40	47uF, CE, 10V, 20%, RLT, 5X11, 105C	157C-476M+K-IUT	4
C41	3300pF, CC, 1000V, 10%, RLT, 10X4, X7R, 125C	150N-332K+K-SG	4
C42	47pF, CC, 1000V, 10%, RLT, 6X3, X7R, 125C	150N-470K+K-KE	4
C44	0.01uF, CC, 50V, 5%, 0603	150F-103J+P-AC	4
C47	0.01uF, CC, 50V, 5%, 0603	150F-103J+P-AC	4
C48	220pF, CC, 50V, 5%, 0603	150F-221J+P-AC	4
C49	0.01uF, CC, 50V, 5%, 0603	150F-103J+P-AC	4
C51	220pF, CC, 50V, 5%, 0603	150F-221J+P-AC	4
C53	0.01uF, CC, 50V, 5%, 0603	150F-103J+P-AC	4
C55	0.1uF, CC, 50V, 10%, 0603/1608, 1x2	150F-104K+P-AC	4
C56	0.01uF, CC, 50V, 5%, 0603	150F-103J+P-AC	4
C57	1000pF, CC, 50V, 5%, 0603, X7R	150F-102J+P-AC	4
C58	1000pF, CC, 50V, 5%, 0603, X7R	150F-102J+P-AC	4
C60	0.01uF, CC, 50V, 5%, 0603	150F-103J+P-AC	4
C61	220pF, CC, 50V, 5%, 0603	150F-221J+P-AC	4
C62	1000pF, CC, 50V, 5%, 0603, X7R	150F-102J+P-AC	4

Electrical Part List

Power Amplifier PCB Assembly

Capacitors (continued)

Reference Designator	Description	Vendor Part Number	Note
C63	0.1uF, CC, 100V, 10%, 1206, AVX	150H-104K+6-CFD	4
C64	0.01uF, CC, 50V, 5%, 0603	150F-103J+P-AC	4
C65	0.01uF, CC, 50V, 5%, 0603	150F-103J+P-AC	4
C66	0.01uF, CC, 50V, 5%, 0603	150F-103J+P-AC	4
C67	0.01uF, CC, 50V, 5%, 0603	150F-103J+P-AC	4
C68	0.01uF, CC, 50V, 5%, 0603	150F-103J+P-AC	4
C69	0.1uF, CC, 50V, 5%, 0805, 1.25X2	150F-104J+J-BD	4
C70	0.1uF, CC, 50V, 5%, 0805, 1.25X2	150F-104J+P-AC	4
C71	0.1uF, CC, 50V, 10%, 0805, 1.2X2.0	150F-104K+J-BD	4
C72	0.01uF, CC, 50V, 5%, 0603	150F-103J+P-AC	4
C73	0.01uF, CC, 50V, 5%, 0603	150F-103J+P-AC	4
C74	220pF, CC, 50V, 5%, 0603	150F-221J+P-AC	4
C75	220pF, CC, 50V, 5%, 0603	150F-221J+P-AC	4
C76	0.1uF, CC, 50V, 10%, 0805, 1.2X2.0	150F-104K+J-BD	4
C77	0.47uF, CC, 25V, 5%, 0805, 1.25X2	150E-474J+J-BD	4
C78	0.1uF, CC, 50V, 10%, 0805, 1.2X2.0	150F-104K+J-BD	4
C80	0.1uF, CC, 50V, 10%, 0603/1608, 1x2	150F-104K+P-AC	4
C81	220pF, CC, 50V, 5%, 0603	150F-221J+P-AC	4
C82	0.1uF, CC, 50V, 5%, 0805, 1.25X2	150F-104J+P-AC	4
C83	1000pF, CC, 250V, 5%, 0805	150R-102J+J-BD	4
C85	1000pF, CC, 250V, 5%, 0805	150R-102J+J-BD	4
C86	0.1uF, CC, 50V, 10%, 0603/1608, 1x2	150F-104K+P-AC	4
C87	0.1uF, CC, 50V, 10%, 0603/1608, 1x2	150F-104K+P-AC	4
C88	0.1uF, CC, 50V, 5%, 0805, 1.25X2	150F-104J+P-AC	4
C89	0.1uF, CC, 50V, 5%, 0805, 1.25X2	150F-104J+P-AC	4
C90	0.1uF, CC, 50V, 5%, 0805, 1.25X2	150F-104J+P-AC	4
C91	0.1uF, CC, 50V, 10%, 0603/1608, 1x2	150F-104K+P-AC	4
C92	0.1uF, CC, 50V, 10%, 0603/1608, 1x2	150F-104K+P-AC	4
C93	0.1uF, CC, 50V, 10%, 0603/1608, 1x2	150F-104K+P-AC	4
C94	0.1uF, CC, 50V, 10%, 0603/1608, 1x2	150F-104K+P-AC	4
C95	0.1uF, CC, 100V, 10%, 1206, AVX	150H-104K+6-CFD	4
C96	0.1uF, CC, 100V, 10%, 1206, AVX	150H-104K+6-CFD	4
C97	0.1uF, CC, 50V, 10%, 0805, 1.2X2.0	150F-104K+J-BD	4
C98	1uF, CC, 50V, 10%, 0805	150F-105K+J-BD	4
C99	1uF, CC, 50V, 10%, 0805	150F-105K+J-BD	4
C100	0.1uF, CC, 50V, 10%, 0805, 1.2X2.0	150F-104K+J-BD	4
C101	0.1uF, CC, 50V, 5%, 0805, 1.25X2	150F-104J+P-AC	4
C102	0.1uF, CC, 50V, 10%, 0603/1608, 1x2	150F-104K+P-AC	4
C103	0.1uF, CC, 50V, 10%, 0603/1608, 1x2	150F-104K+P-AC	4
C104	0.1uF, CC, 50V, 5%, 0805, 1.25X2	150F-104J+P-AC	4
C105	220pF, CC, 50V, 5%, 0603	150F-221J+P-AC	4
C106	220pF, CC, 50V, 5%, 0603	150F-221J+P-AC	4
C107	1uF, CC, 50V, 10%, 0805	150F-105K+J-BD	4
C108	1uF, CC, 50V, 10%, 0805	150F-105K+J-BD	4
C109	0.1uF, CC, 50V, 10%, 0603/1608, 1x2	150F-104K+P-AC	4
C110	0.1uF, CC, 50V, 5%, 0805, 1.25X2	150F-104J+P-AC	4

Electrical Part List

Power Amplifier PCB Assembly

Capacitors (continued)

Reference Designator	Description	Vendor Part Number	Note
XYC1	680pF, CC, 400V, 10%, RL, 10X8	150T-681K+5-SO	4
XYC3	680pF, CC, 400V, 10%, RL, 10X8	150T-681K+5-SO	4
XYC5	1000pF, CC, 400V, 20%, RL, Y5, U, 9.5X8, AH09E102MLO	150T-102M+5-RO	4
YC6	1000pF, CC, 400V, 20%, RL, Y5, U, 9.5X8, AH09E102MLO	150T-102M+5-RO	4
YC7	1000pF, CC, 400V, 20%, RL, Y5, U, 9.5X8, AH09E102MLO	150T-102M+5-RO	4

Inductors

Reference Designator	Description	Vendor Part Number	Note
L1	FERRITE BEAD, INDUCTOR, BL01RN1A1F1J	1808-0680+0	4
L2	CHOKE-COMMON MODE, 10MH MIN, AC, 240V, 2A, AL	1806-4037+0000	3, 4 
L3	FERRITE BEAD, INDUCTOR, BL01RN1A1F1J	1808-0680+0	4
L4	CHOKE-COMMON MODE, 10MH MIN, AC, 240V, 2A, AL	1806-4037+0000	3, 4 
L5	FERRITE BEAD, INDUCTOR, BL01RN1A1F1J	1808-0680+0	4
L6	FERRITE BEAD, INDUCTOR, BL01RN1A1F1J	1808-0680+0	4
L7	CHOKE-COMMON MODE, 2X16UH, 8A, FT50-43	1806-3913+0	4
L8	WIRE JUMPER, ROLLER FORM, D=0.6MM	635N-0002+0	4
L10	WIRE JUMPER, ROLLER FORM, D=0.6MM	635N-0002+0	4
L11	WIRE JUMPER, ROLLER FORM, D=0.6MM	635N-0002+0	4
L12	WIRE JUMPER, ROLLER FORM, D=0.6MM	635N-0002+0	4
L13	CHOKE-COMMON MODE, 2X16UH, 8A, FT50-43	1806-3913+0	4
L14	FERRITE COIL, 22uH, 20%, BL19.2	1807-220M+9	4
L15	FERRITE COIL, 22uH, 20%, BL19.2	1807-220M+9	4
L19	FERRITE BEAD, INDUCTOR, BL01RN1A1F1J	1808-0680+0	4
L21	FERRITE BEAD, SMD, ACB453215, 125 OHM	1802-0630+0	4
L22	FERRITE BEAD, SMD, ACB453215, 125 OHM	1802-0630+0	4
L23	FERRITE BEAD, INDUCTOR, BL01RN1A1F1J	1808-0680+0	4
L24	FERRITE BEAD, INDUCTOR, BL01RN1A1F1J	1808-0680+0	4
L25	FERRITE BEAD, SMD, ACB453215, 125 OHM	1802-0630+0	4
L26	FERRITE BEAD, INDUCTOR, BL01RN1A1F1J	1808-0680+0	4
L27	FERRITE BEAD, SMD, ACB453215, 125 OHM	1802-0630+0	4

Electrical Part List

Power Amplifier PCB Assembly





Diodes

Reference Designator	Description	Vendor Part Number	Note
B1	DIODE BRIDGE, 800V, 8A, GBU8K, RL	4840-9218+5	3, 4 
D1	BAV21W, 200V, 0.2A, SOD-123, SMD	480V-21W0+3	4
D2	RECTIFIER, UF4006-T GI, AT	4840-8530+2	4
D3	MUR1640, ULTRA, 400V, 16A, TO-220AB	4801-6400+9	4
D4	MUR1640, ULTRA, 400V, 16A, TO-220AB	4801-6400+9	4
D5	RECTIFIER, ES1D, 200V, 1.1A, SMD	4840-9190+3	4
D6	RECTIFIER, ES1D, 200V, 1.1A, SMD	4840-9190+3	4
D7	LL4148, SM	4804-1480+3	4
DZ1	P6KE200A, SUPPRESSOR, 200V, AT	4802-00A0+2	4
Z1	ZENER, 5W, 10V, 2%, AXIAL, AT	483B-1009+2	4
Z2	ZENER, 5W, 10V, 2%, AXIAL, AT	483B-1009+2	4
Z3	ZENER, 1/2W, 30V, 5%, SM	4837-3009+3	4
Z4	ZENER, 1/2W, 22VD, RLZTE-1122D, LL-34, ROHM	4837-22D1+3	4
Z5	ZENER, 1/2W, 5.6V, SMD	4837-5V69+3	4
Z6	ZENER, 1/2W, 15V, 5%, SOD-123C, MMSZ5245BT1G	4837-15V9+3	4
Z7	ZENER, 5W, 10V, 2%, AXIAL, AT	483B-1009+2	4

Transistors

Reference Designator	Description	Vendor Part Number	Note
Q1	2N2222, SMD, MMBT2222ALT1G	4860-5410+3	4
Q2	2N2222, SMD, MMBT2222ALT1G	4860-5410+3	4











Integrated Circuits

Reference Designator	Description	Vendor Part Number	Note
U1	PWM CONT, TOP258YN, TO-220-7C, PI	3132-7241+0-35	3, 4 
U2	PHOTOCOUPLER, EL817, EVERLIGHT	481E-L817+3	3, 4 
U3	PWR AMP, TDA8920BTH/N2, SOT566-3, PHILIPS	3132-2641+0	3, 4 
U3	MICA SHEET, INSULATOR, 16.5X12	3100-6701+0	3, 4 
U4	REGULATOR, TL432BIDBZR, SOT-23-3, TI	3132-7691+0-16	3, 4 

Electrical Part List

Power Amplifier PCB Assembly

Miscellaneous

Reference Designator	Description	Vendor Part Number	Note
AMP	HEATSINK, AMP, 160X120, AL PLATE	5401-0191+0	4
CN1	WAFER, 3 PIN, P=3.96	2101-3065+0	4
CN2	CONNECTOR, 2P, P3.96, STRAIGHT, M	2101-2780+0	4
CN3	WAFER, 10 PIN, P2	2102-100S+003	4
CX1	0.33uF, CM, 300V, 10%, RB, P15, 18X15.5X10	1511-334K+9-03Z	3, 4 
CX2	0.33uF, CM, 300V, 10%, RB, P15, 18X15.5X10	1511-334K+9-03Z	3, 4 
FUS1	FUSE, T5A, 250V, 8X8.5, VDE/PSE/CCC, RLT, LITTELFUSE	5120-1144+0-L	3, 4 
FUS2	FUSE, 0.5A, 63V, UL/CSA, 1206, LITTELFUSE	5120-1145+0-L (Bose part number 319970-000S)	3, 4 
FUS3	FUSE, 0.5A, 63V, UL/CSA, 1206, LITTELFUSE	5120-1145+0-L (Bose part number 319970-000S)	3, 4 
HS	VULCANIZED FIBRE, INSULATION, 128X76X0.5	3100-7791+0	3, 4 
HS1	SCREW, M3X10, (BLK)	2904-3010+3000	4
HS1	HEATSINK, SMPS, 44X46, AL EXTRU	5400-3612+0	4
HS2	SCREW, PAN HEAD, B-TITE, 2.6X8, BLACK	2950-2608+3000	4
HS2	SCREW, 3X8, TAPPING	2950-3008+3000	4
HS2	HEATSINK, 214, 20MM-HIGH HOLE	5400-0831+0	4
HS3	SCREW, PAN HEAD, B-TITE, 2.6X8, BLACK	2950-2608+3000	4
HS3	SCREW, 3X8, TAPPING	2950-3008+3000	4
HS3	HEATSINK, 214, 20MM-HIGH HOLE	5400-0831+0	4
J1	WAFER, 3P, P7.92/11.88, STRAIGHT	2101-3097+0	4
RV1	SURGE PROTECTOR, 270V, 4500A, D15, THINKING	2706-0003+0	3, 4 
RV2	SURGE PROTECTOR, 270V, 4500A, D15, THINKING	2706-0003+0	3, 4 
SMPS PCB	I/T, WASHER, M3X0.5X6.4, WZ	2606-3005+0642	4
SMPS PCB	SCREW, MACHINE, PAN, M3X6, CS-RECESS, YZ	2900-3006+0000	4
T1	TRANSFORMER, SW, IN150-288, OUT+/-27V, 52W, ER	1806-4051+0000	3, 4 
TH1	NTC, THERMISTER, 50HM, 4A, NIOSP005L, UL/CSA/VDE	5202-0010+0	3, 4 
-	CASING ASSY PAMP COMMON BSPACAJUN+07CS01	SS-CAJUN01+PAMP	4

Disassembly Procedures

L1 Compact Power Stand Procedures

CAUTION: The SMD integrated circuits used on the Input / Output PCB are extremely sensitive to ESD damage. Be sure to use an approved and tested ESD strap that is properly grounded to your work bench before attempting disassembly or repair of the L1 Compact Power Stand.

1. Top Cover Removal

1.1 Remove the two screws that secure the Power Stand handle to the top cover. Lift off the handle.

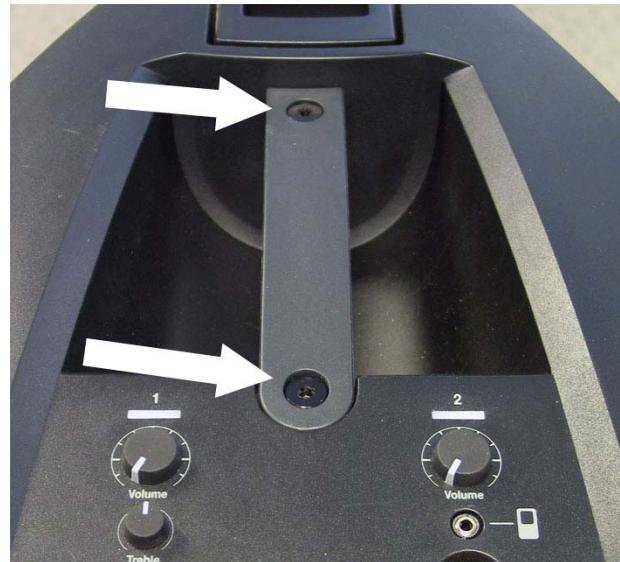

1.2 Lift up on the top cover. Unplug the two cable harnesses from the I/O board at connector CNxxx and from the line output card at connector CN302B. Lift off the top cover.

Re-assembly Note: Be sure the woofer grilles are properly aligned into the front groove of the top cover before re-installing the handle.

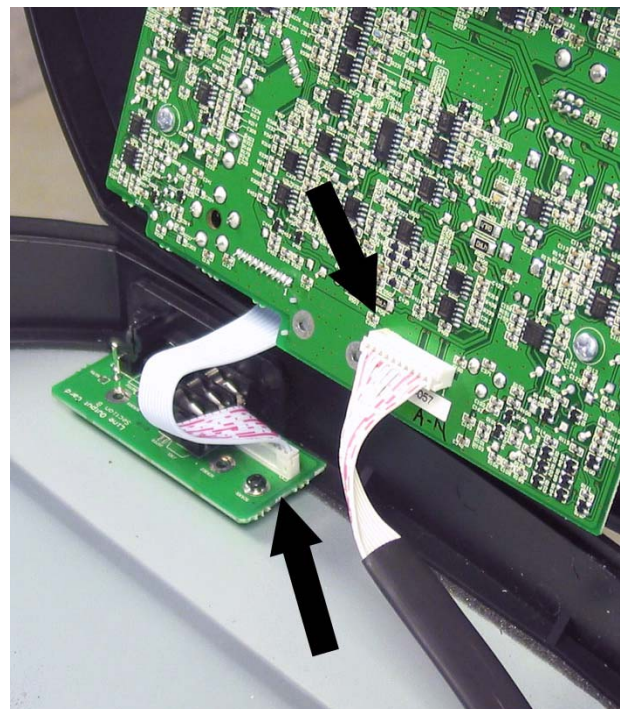

Disassembly Procedures

2. Input / Output PCB Removal

CAUTION: The SMD integrated circuits used on the Input / Output PCB are extremely sensitive to ESD damage. Be sure to use an approved and tested ESD strap that is properly grounded to your work bench before attempting disassembly or repair of the L1 Compact Power Stand.

2.1 Perform procedure 1.

2.2 Remove the four knobs (volume 1, volume 2, treble, bass) on the Input/Output panel.

2.3 Remove the following items from the top cover:

- two screws at the microphone jack.
- one screw at the RCA input jacks.
- ring at the 3.5mm input jack.
- hex nut at the 1/4" input jack.

2.4 Turn over the top cover. Remove the four screws that secure the I/O board. Lift off the board.

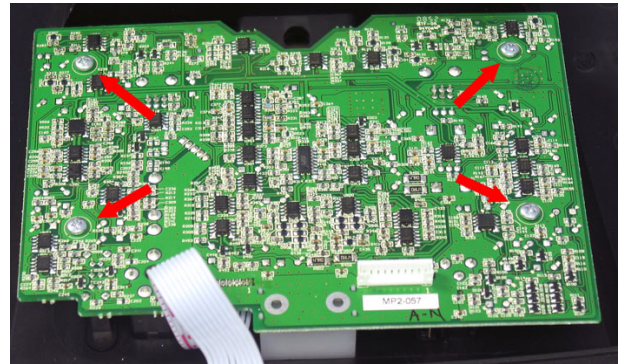

3. Jack Input PCB Removal

Note: The jack input PCB is a plug-in daughter card located on the I/O PCB.

3.1 Perform procedure 2.

3.2 Unplug the jack input PCB from the I/O PCB at connector CN308A. Lift off the board.

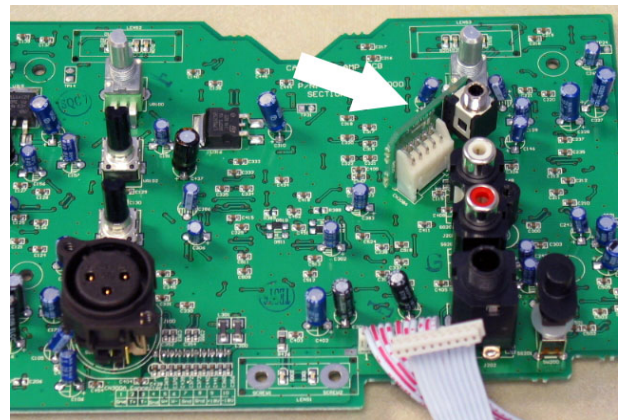

Disassembly Procedures

Input/Output PCB Re-assembly Note:

Be sure that the LED lightpipes are properly aligned with the holes in the PCB and the openings in the top cover when re-installing the I/O PCB assembly.

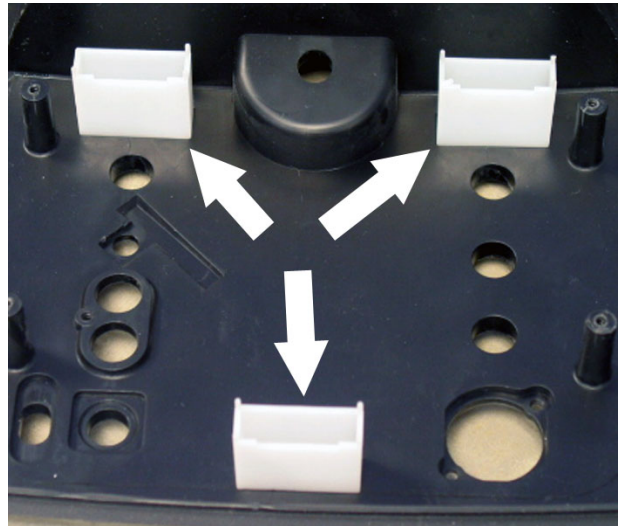

4. Line Output Card Removal

4.1 Perform procedure 1.

4.2 Remove the one screw at the RCA jacks and the plastic nut at the 1/4" jack.

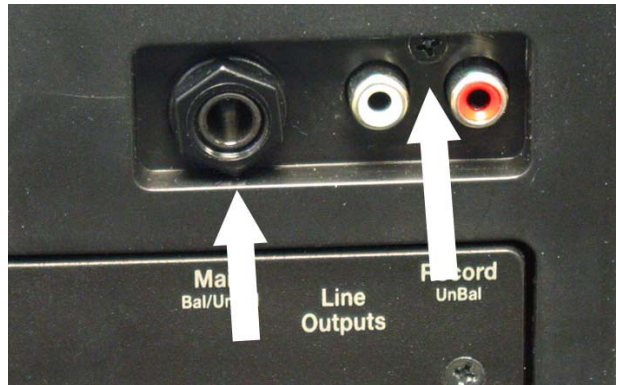

4.3 Remove the one screw that secures the line output card to the metal plate. Lift out the card.

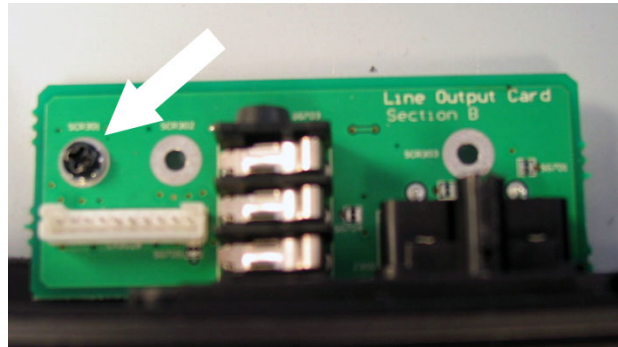

5. Power Amplifier / SMPS PCB Removal

5.1 Remove the six screws that secure the rear access panel. Lift off the panel.

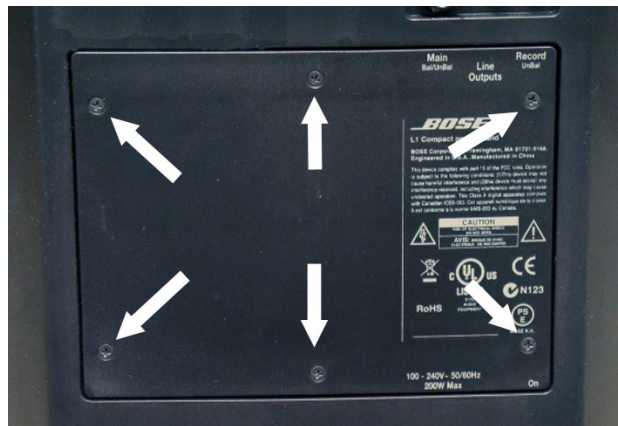

Disassembly Procedures

5.2 Remove the four screws that secure the power amplifier / SMPS PCB assembly to the power stand's mounting bracket.

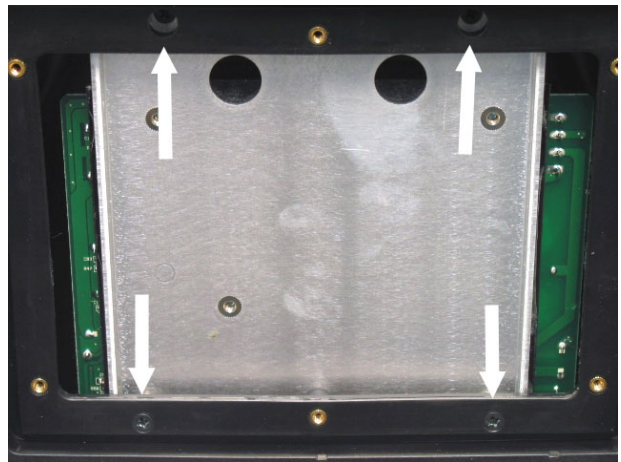

5.3 Carefully slide the power amplifier / SMPS PCB downward until the top of the board clears the upper part of the bracket.

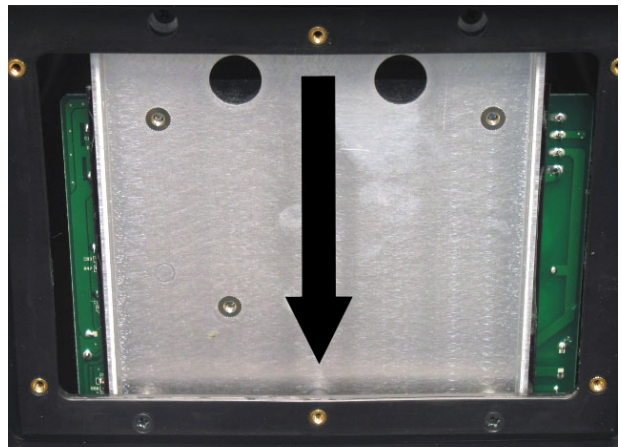

5.4 Slide the PCB assembly out through the access panel opening and disconnect the four wire harnesses. Lift out the board.
Re-assembly Note: The power amplifier / SMPS PCB assembly with the heatsink attached should slide up between the plastic cabinet housing and the metal cavity bulk-head bracket. Once it is in the correct location, secure it in place with the four screws removed in step 5.2.



Disassembly Procedures

6. AC Inlet and Power Switch Removal

6.1 Perform procedure 5.

6.2 Disconnect the three wires that connect to the AC inlet jack. Remove the two screws that secure the AC inlet to the cabinet. Lift out the jack.

6.3 Disconnect the two wires that connect to the AC power switch. Lift out the switch

Note: The AC inlet and power switch are secured to the cabinet with glue to prevent air leaks. Be sure to re-seal the new parts.

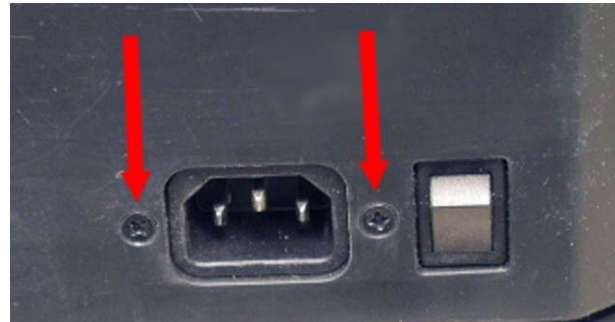

7. Woofer Removal

7.1 On the bottom of the Power Stand, remove the four screws located toward the center of the plastic foot. These are not the screws that hold the rubber feet in place.

7.2 Remove the four screws that secure the bottom of the array connector housing to the foot. Lift off the plastic foot.

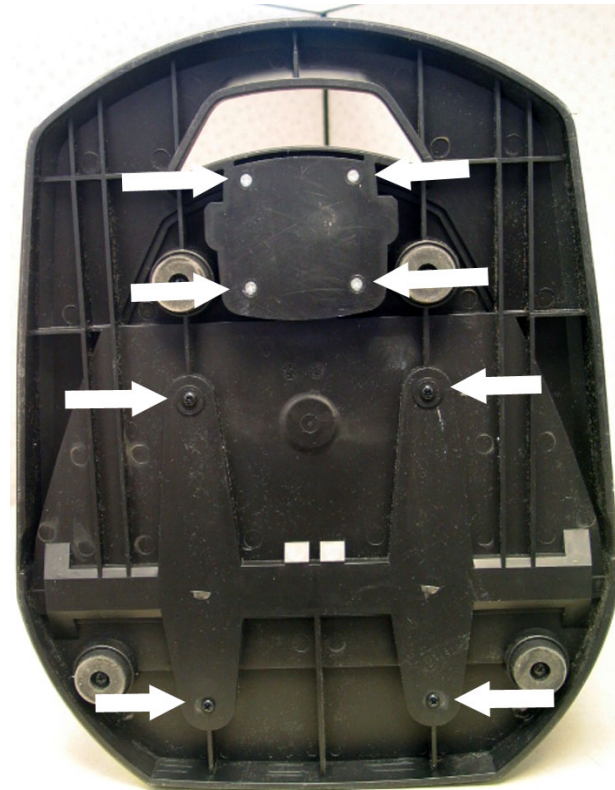

7.3 Lift out the woofer grilles and set them aside.



Disassembly Procedures

7.4 Remove the one screw that secures the array guide to the cabinet. Slide the array guide down and out from in front of the woofer.



7.5 Remove the four screws that secure the woofer to the cabinet. Lift out the woofer. Disconnect the two faston connectors from the woofer.

Re-assembly Note: Be sure to align the woofer grilles to the slots in the top cover and the plastic foot when replacing the foot.



L1 Compact Array Procedures

1. Grille Removal

1.1 Grasp the grille and carefully pull it away from the array. Lift off the grille.

Re-assembly Note: Be sure there is sufficient damping material in the array grooves to retain the grille and prevent buzzes. Perform the array sweep tests after replacing the grille.



Disassembly Procedures

2. Driver Removal

2.1 Perform procedure 1.

2.2 Remove the four screws that secure the driver to the baffle. Lift out the driver.

2.3 Cut the wires as close to the driver terminals as possible.

Re-assembly Note: Be sure to observe polarity when re-connecting the driver wires. There may be more than one wire per connection.

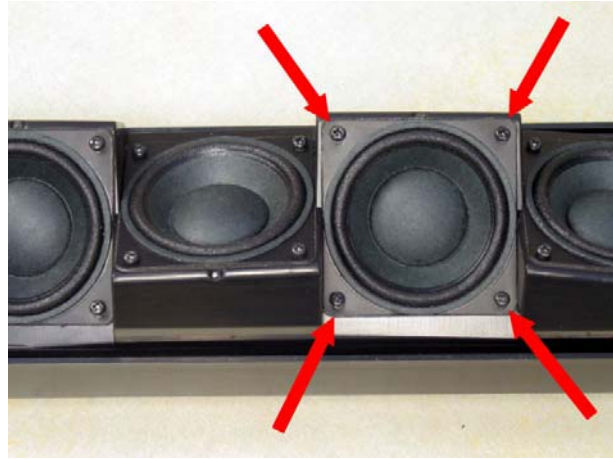

3. Logo Removal

3.1 Perform procedure 1.

3.2 Unbend the legs of the logo and lift it off the grille.

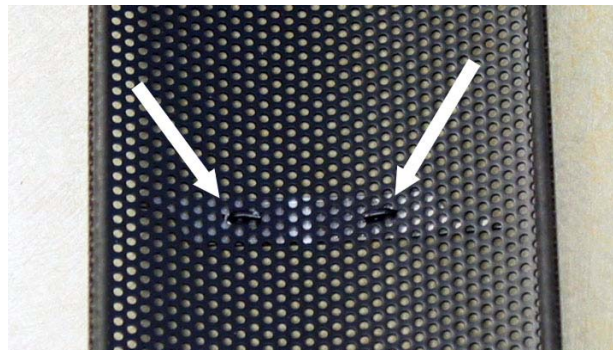

Array Extensions

Note: The array extensions are not repairable. If damaged they must be replaced.

Test Procedures

L1® Compact Power Stand Tests

CAUTION: The SMD integrated circuits used on the Input / Output PCB are extremely sensitive to ESD damage. Be sure to use an approved and tested ESD strap that is properly grounded to your work bench before attempting disassembly or repair of the L1 Compact Power Stand.

Equipment Required

- dB Meter
- Digital Multi-meter
- Audio Signal Generator
- Distortion Meter
- 2 - 4 Ohm, 50 Watt Load Resistors
- Test cables, see Appendix

Note:

- Channel 1 refers to the left Side of the power stand input panel that has the XLR Microphone Jack. Channel 2 refers to the right side with the TRS (1/4"), RCA and 1/8" input jacks.
- When testing Channel 1, turn Channel 2 Volume to Min. When testing Channel 2, turn Channel 1 Volume to Min.

Note: The following tests will check the performance of the Input PCB, I/O PCB and the Output PCB assemblies

1. Channel 1 LED/Gain Test

1.1 Using an XLR cable, apply a balanced, 1kHz, -50dBV (3.16mVrms) sine wave to the channel 1 XLR microphone input. Adjust the volume control so that you measure the -50dBV output level at the 1/4" balanced line output jack on the back of the power stand.

1.2 While measuring the output level at the 1/4" balanced line output jack, increase the volume level on the channel 1 input and verify that the LED functions, and record the levels at which the trim LED's color states change. The LED should turn green at -30 +/-2dBV (31.6mVrms), and red at 0 +/-2 dBV (1Vrms).

2. Channel 2 LED/Gain Test

2.1 Set the channel 2 ToneMatch switch to the OFF position (down).

2.2 Using an balanced TRS cable, apply a balanced, 1kHz, -50dBV (3.16mVrms) sine wave to the channel 1 balanced 1/4" input jack. Adjust the volume control so that you measure the -50dBV output level at the 1/4" balanced line output jack on the back of the power stand.

2.3 While measuring the output level at the 1/4" balanced line output jack, increase the volume level on the channel 2 input and verify that the LED functions, and record the levels at which the trim LED's color states change. The LED should turn green at -30 +/-2dBV (31.6mVrms), and red at 0 +/-2 dBV (1Vrms).

2.4 Repeat steps 2.2 and 2.3 for the channel 2 unbalanced RCA and 1/8" stereo input jacks.

3. Channel 2 Line Output Test

3.1 Set the channel 2 ToneMatch switch to the OFF position (down). Set the channel 2 volume control to maximum.

3.2 Using an balanced TRS cable, apply a balanced, 1kHz, -41dBV (9mVrms) sine wave to the channel 2 balanced 1/4" input jack.

3.3 Measure the output level at the 1/4" balanced line output jack. It should be 0dBV +/- 1dBV (1Vrms).

3.4 Measure the output level at the unbalanced RECORD output RCA jacks. It should be -6dBV +/- 1dBV (0.5Vrms).

3.5 Apply a, 1kHz, -24dBV (63mVrms) sine wave to both of the channel 2 RCA input jacks.

Test Procedures

3.6 Measure the output level at the 1/4" balanced line output jack. It should be 0dBV +/- 1dBV (1Vrms).

3.7 Measure the output level at the unbalanced RECORD output RCA jacks. It should be -6dBV +/- 1dBV (0.5Vrms).

3.8 Repeat steps 3.5 to 3.7 for the channel 2 1/8" stereo input jack.

4. Channel 1 EQ Frequency Response Test

4.1 Set the channel 1 volume control to maximum (fully CW). Set the bass and treble tone controls to 12 o'clock (straight up).

4.2 Apply a balanced 1kHz, -55dBV (1.8mVrms) sine wave to the XLR microphone input.

4.3 Measure the output level at the 1/4" balanced Main output on the back of the power stand. It should be -4.5dB +/- 1.5dB (0.6Vrms).

4.4 Reference a dB meter to the output level at 1 kHz. Ensure that the frequency response is within the limits listed in the following table.

Frequency	Output Level
50 Hz	-11.1 dBr +/- 2.0 dB
65 Hz	-5.4 dBr +/- 1.5 dB
100 Hz	+0.9 dBr +/- 1.5 dB
150 Hz	-1.0 dBr +/- 1.5 dB
300 Hz	-4.4 dBr +/- 1.5 dB
550 Hz	-6.6 dBr +/- 1.5 dB
1 kHz	REFERENCE
1.5 kHz	+2.5 dBr +/- 1.5 dB
3 kHz	+5.5 dBr +/- 1.5 dB
10 kHz	+2.6 dBr +/- 1.5 dB
18 kHz	+0.2 dBr +/- 2.0 dB

5. Channel 2 ToneMatch Not Active EQ Check

5.1 Set the channel 2 volume control to the 12 o'clock position. Set the ToneMatch switch to the OFF position (down).

5.2 Using a balanced TRS cable, apply a 50HZ, -50dBV (3.16mVrms) sine wave to the 1/4" balanced TRS input jack.

5.3 Sweep the audio input from 50Hz to 15kHz. Measure the output level at the Main output jack on the back of the power stand using a balanced TRS cable. Verify that the audio bandwidth is 50Hz to 15kHz, +/- 1dB.

6. Channel 2 ToneMatch Active EQ Frequency Response Test

6.1 Set the channel 2 volume control to the MAXIMUM (fully CW) position. Set the ToneMatch switch to the ON position (up).

6.2 Using a balanced TRS cable, apply a 1 kHz, -40dBV (10mVrms) sine wave to the 1/4" balanced TRS input jack.

6.3 Measure the output level at the 1/4" balanced Main output on the back of the power stand. It should be -2.8dB +/- 1.5dB (0.72Vrms).

6.4 Reference a dB meter to the output level at 1 kHz. Ensure that the frequency response is within the limits listed in the following table.

Frequency	Output Level
74 Hz	-3.9 dBr +/- 1.5 dB
120 Hz	+1.2 dBr +/- 1.5 dB
250 Hz	+2.3 dBr +/- 1.5 dB
515 Hz	-4.0 dBr +/- 1.5 dB
725 Hz	-5.0 dBr +/- 1.5 dB
1 kHz	REFERENCE
2 kHz	+3.1 dBr +/- 1.5 dB
4 kHz	+4.0 dBr +/- 1.5 dB
7 kHz	+3.8 dBr +/- 1.5 dB
14 kHz	-3.9 dBr +/- 1.5 dB

Test Procedures

Note: The following tests will check the performance of the Power Supply / Amplifier PCB assembly

7. Channel 1 Line Array Amplifier THD+N Test

7.1 Set the channel 1 volume, bass and treble tone controls to the 12 o'clock setting (straight up).

7.2 Connect a 4 Ohm, 50 Watt load resistor to the line array output.

7.3 Apply a balanced 1kHz, -50dBV (3.16mVrms) sine wave to the channel 1 microphone XLR input jack.

7.4 Measure the THD+N level. It should be < 1%.

8. Power Amplifier Gain and THD+N Test

Note: During these high power tests, take care to not operate the amplifier for a long period of time to avoid overheating the amplifier output IC.

8.1 Set the channel 2 ToneMatch switch to OFF.

8.2 Set the channel 2 volume control to the 12 o'clock setting.

8.3 Verify that the AC line cord is not connected to the unit under test. On the back of the power stand, remove the 6 screws that secure the rear cover. Lift off the cover. Remove the 4 screws that secure the power supply / power amplifier PCB to the power stand. Slide the PCB down and out of the power stand so that the component side of the board is facing upward.

8.4 Connect a 4 Ohm, 50 Watt load resistor to pins 1 and 2 the high frequency array output connector CN1.

8.5 Connect a 4 Ohm, 50 Watt load resistor to pins 1 and 2 of the bass amplifier output connector CN2. These connectors are located near the bottom of the PCB assembly.

8.6 Re-connect the AC line cord and turn on the power stand at the AC power switch.

8.7 Apply a balanced 1kHz, 0dBV (1Vrms) sine wave to the channel 2 balanced 1/4" input jack.

8.8 Reference a dB meter to the input level. Measure the output gain level at the line array's 4 ohm load resistor. It should be +28.4dB minimum.

8.9 Measure the THD+N level. It should be ≤ 1%.

8.10 Apply a balanced 100 Hz, 0dBV (1Vrms) sine wave to the channel 2 balanced 1/4" input jack.

8.11 Reference a dB meter to the input level. Measure the output gain level at the woofers's 4 ohm load resistor. It should be +28.4dB minimum.

8.12 Measure the THD+N level. It should be ≤ 1%.

8.13 Re-install the power supply / power amplifier PCB assembly into the power stand. Replace the rear cover. Perform the system sweep test below to ensure there are no air leaks in the power stand.

9. System Sweep Test

9.1 Set up the system in the collapsed position.

9.2 Set the channel 2 ToneMatch switch to the OFF position (down). Set the channel 2 volume control to maximum.

9.3 Apply a 50 Hz, -34dBV (20mVrms) sine wave to both of the channel 2 RCA input jacks.

Test Procedures

9.4 Sweep the audio signal generator from 50Hz to 15kHz. Sweep duration should be about 3 seconds up and 3 seconds down.

9.5 Listen carefully for buzzes, rattles, or other extraneous noises from the array drivers or woofer or from the internal parts. Verify that there are no air leaks from the power stand cabinet. The whooshing noise from the port around 65Hz is acceptable.

Note: If you have the customer's array extensions with the system, set up the system in the extended position instead of the collapsed position and perform steps 9.2 to 9.5.

L1 Compact Line Array Tests

Set up the unit under test as shown below.

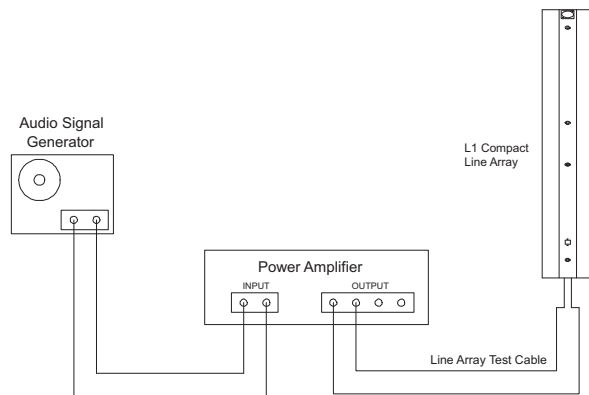

1. Air Leak Test

1.1 Apply a 65Hz, 1Vrms sine wave to the unit under test.

1.2 Listen carefully for air leaks from around the end cap, the transducers and the grille. Air leaks will be heard as a hissing or sputtering sound. All repairs must be hidden. Test duration should be 5 seconds minimum.

2. Transducer Rub and Tick Test

2.1 Remove the transducer you wish to test using the disassembly procedures in this manual.

2.2 Connect a signal generator directly to the terminals of the transducer assembly under test.

2.3 Apply a 65Hz, 1Vrms sine wave to the transducer assembly.

2.4 Listen carefully for any extraneous noises such as rubbing, scraping or ticking.

Note: To distinguish between normal suspension noise and rubs or ticks, displace the cone slightly with your fingers. If the noise stays the same, it is normal suspension noise and the driver is good. Suspension noise will not be heard with program material.

3. Transducer Phase Test

3.1 Momentarily apply a DC voltage of 5V, positive applied to the positive tab of the dual banana jack on the line array test cable and negative applied to negative (gnd) tab.

3.2 All of the driver cones should move outward when the DC voltage is applied.

3.3 Rewire any incorrectly connected transducers.

4. Line Array Sweep Test

4.1 Set up the upper or lower line array section as shown in the figure on the previous page.

4.2 Apply a 100 Hz, 10Vrms sine wave to the amplifier input.

4.3 While listening to the output of the system, sweep the input frequency slowly from 100 Hz to 15 kHz.

4.4 Listen carefully for any extraneous noises such as buzzing and ticking.

IC Diagrams

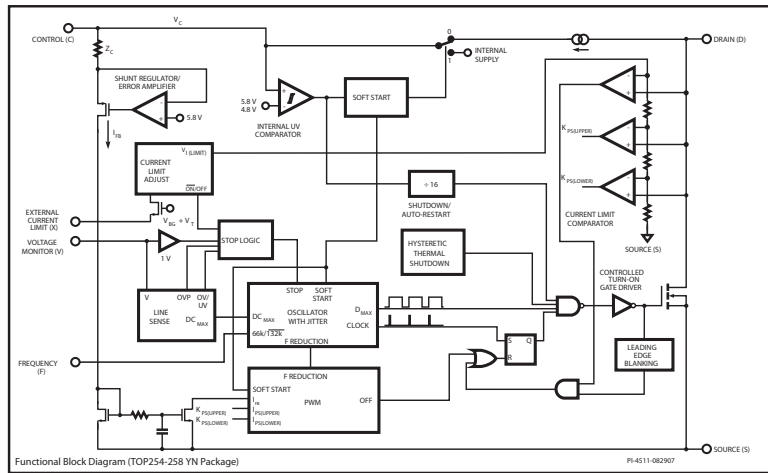
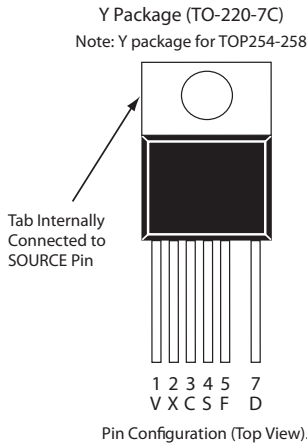

Pin Functional Description

DRAIN (D) Pin:

High-voltage power MOSFET DRAIN pin. The internal start-up bias current is drawn from this pin through a switched high-voltage current source. Internal current limit sense point for drain current.

CONTROL (C) Pin:

Error amplifier and feedback current input pin for duty cycle control. Internal shunt regulator connection to provide internal bias current during normal operation. It is also used as the connection point for the supply bypass and auto-restart/compensation capacitor.

EXTERNAL CURRENT LIMIT (X) Pin (Y, M, E and L package):

Input pin for external current limit adjustment and remote ON/OFF. A connection to SOURCE pin disables all functions on this pin.

VOLTAGE MONITOR (V) Pin (Y & M package only):

Input for OV, UV, line feed forward with DC_{MAX} reduction, output overvoltage protection (OVP), remote ON/OFF and device reset. A connection to the SOURCE pin disables all functions on this pin.

FREQUENCY (F) Pin (TOP254-258Y, and all E and L packages):

Input pin for selecting switching frequency 132 kHz if connected to SOURCE pin and 66 kHz if connected to CONTROL pin. The switching frequency is internally set for fixed 66 kHz operation in the P, G, M package and TOP259YN, TOP260YN and TOP261YN.

SIGNAL GROUND (G) Pin (TOP259YN, TOP260YN & TOP261YN only):

Return for C pin capacitor and X pin resistor.

SOURCE (S) Pin:

Output MOSFET source connection for high voltage power return. Primary side control circuit common and reference point.

TOP258YN PWM Controller



EL817

PIN NO. AND INTERNAL CONNECTION DIAGRAM

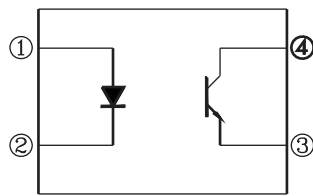

1. Anode 3. Emitter
2. Cathode 4. Collector

EL817 Photocoupler

SOT23-3 PACKAGE (TOP VIEW)

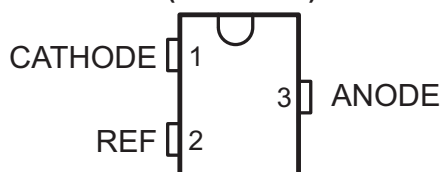

TL432BIDBZR Regulator

Connection Diagram

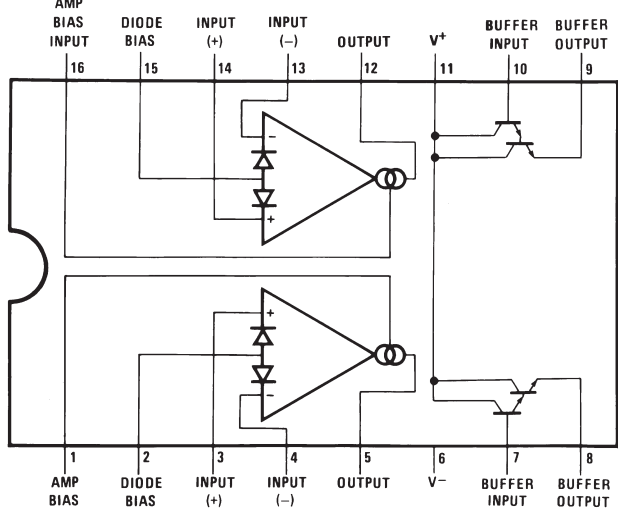

Top View

LM13700 Transconductance Amplifier

IC Diagrams

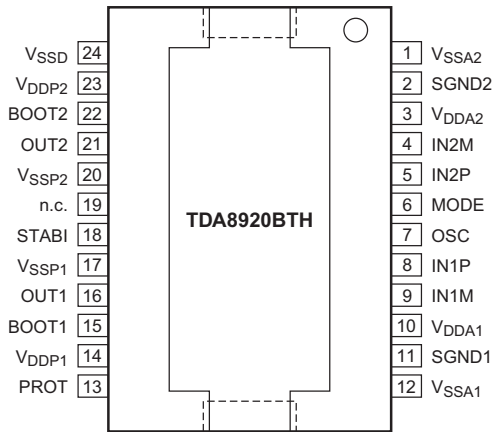

Pin Configuration

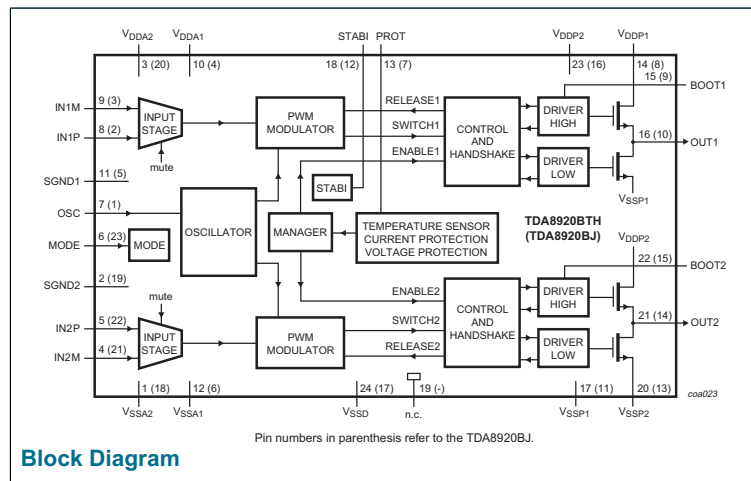

Block Diagram

Pin Description

Symbol	Pin		Description
	TDA8920BTH	TDA8920BJ	
VSSA2	1	18	negative analog supply voltage for channel 2
SGND2	2	19	signal ground for channel 2
VDDA2	3	20	positive analog supply voltage for channel 2
IN2M	4	21	negative audio input for channel 2
IN2P	5	22	positive audio input for channel 2
MODE	6	23	mode selection input: Standby, Mute or Operating mode
OSC	7	1	oscillator frequency adjustment or tracking input
IN1P	8	2	positive audio input for channel 1
IN1M	9	3	negative audio input for channel 1
VDDA1	10	4	positive analog supply voltage for channel 1
SGND1	11	5	signal ground for channel 1
VSSA1	12	6	negative analog supply voltage for channel 1
PROT	13	7	decoupling capacitor for protection (OCP)
VDDP1	14	8	positive power supply voltage for channel 1
BOOT1	15	9	bootstrap capacitor for channel 1
OUT1	16	10	PWM output from channel 1
VSSP1	17	11	negative power supply voltage for channel 1
STABI	18	12	decoupling of internal stabilizer for logic supply
n.c.	19	-	not connected
VSSP2	20	13	negative power supply voltage for channel 2
OUT2	21	14	PWM output from channel 2
BOOT2	22	15	bootstrap capacitor for channel 2
VDDP2	23	16	positive power supply voltage for channel 2
VSSD	24	17	negative digital supply voltage

TDA8920BTH-N2 Power Amplifier

Service Manual Revision History

Date	Revision Level	Description of Change	Change Driven By	Pages Affected
5/09	00	Document released at revision 00.	Service manual release	All
5/09	01	Added power stand packing sheet.	Vendor change	9
3/16	02	New array driver part number	New part number	13
6/17	03	Added Bose part numbers for FUS2 and FUS3 used on SMPS/Amplifier PCB	New part number	37

SPECIFICATIONS AND FEATURES SUBJECT TO CHANGE WITHOUT NOTICE

BOSE[®]
Better sound through research[®]

Bose Corporation
The Mountain
Framingham Massachusetts USA 01701

P/N: 318882-SM Rev. 03; 6/2017 (P)
<http://serviceops.bose.com>