

BLOCK DIAGRAM - PM8500 System + Interconnects

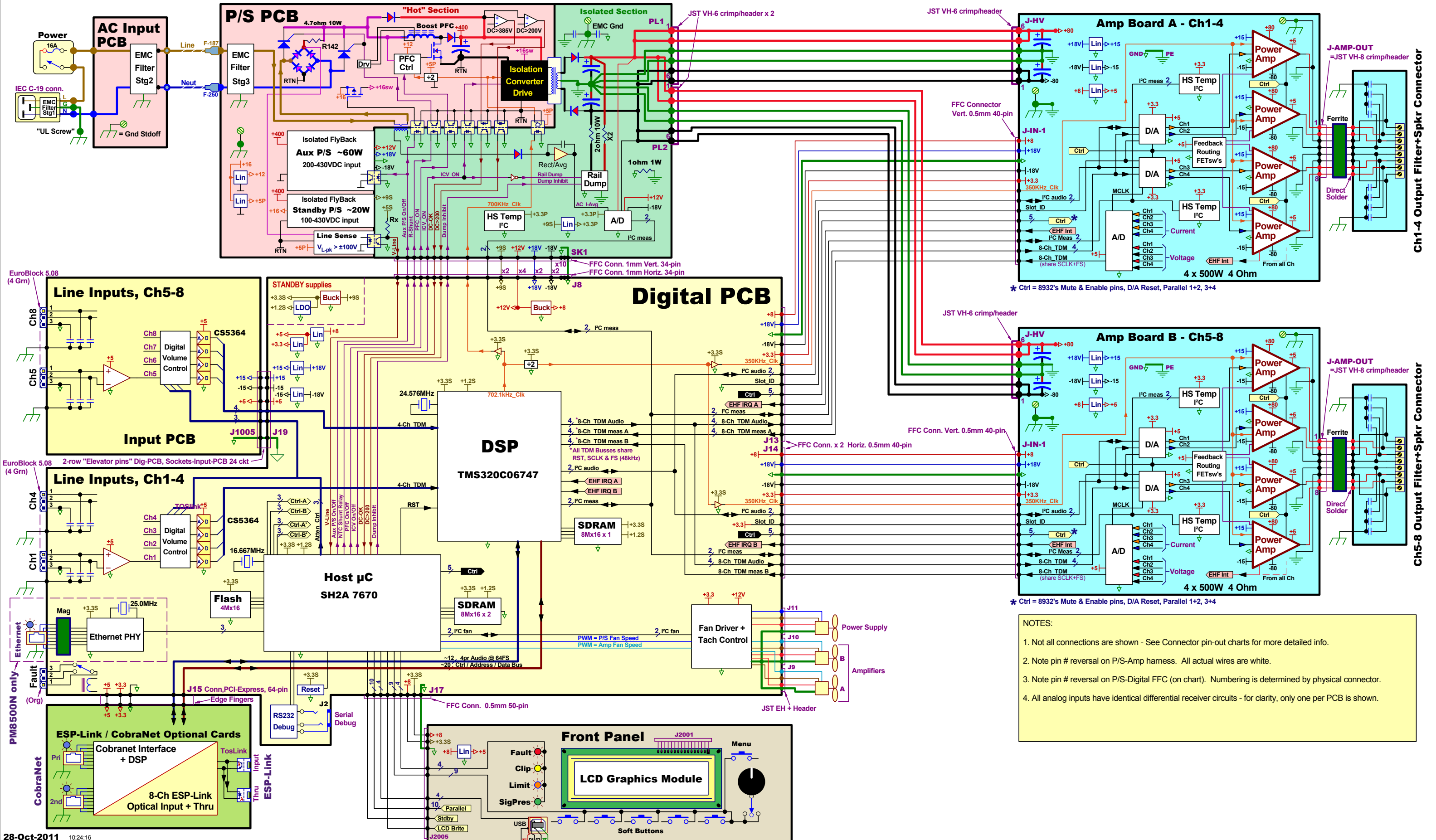

NOTES:

1. Not all connections are shown - See Connector pin-out charts for more detailed info.
2. Note pin # reversal on P/S-Amp harness. All actual wires are white.
3. Note pin # reversal on P/S-Digital FFC (on chart). Numbering is determined by physical connector.
4. All analog inputs have identical differential receiver circuits - for clarity, only one per PCB is shown.