

# ControlSpace<sup>®</sup> ESP-88 Engineered Sound Processor, CC-16 and CC-64 Controllers (US and non-US units)



ESP-88 Engineered Sound Processor



CC-64 Control Center



CC-16 Zone Controller

# CONTENTS

<b>Safety Information</b> .....	3
<b>Warranty</b> .....	3
<b>Product Descriptions</b> .....	4-7
<b>Specifications</b> .....	8-10
<b>Electrostatic Discharge Sensitive (ESDS) Device Handling</b> .....	11
<b>Part List Notes</b> .....	11
<b>Packaging Part List, ControlSpace® ESP-88 Chassis</b> .....	12
Figure 1. ESP-88 Chassis Packing View .....	12
<b>Packaging Part List, ControlSpace CC-16 Controller</b> .....	13
Figure 2. CC-16 Controller Packing View .....	13
<b>Packaging Part List, ControlSpace CC-64 Controller</b> .....	14
Figure 3. CC-64 Controller Packing View .....	14
<b>Main Part List, Control Space ESP-88 Chassis (see Figure 4)</b> .....	15-16
Figure 4. ControlSpace ESP-88 Chassis Exploded View .....	16
<b>Main Part List, ControlSpace CC-16 Controller</b> .....	17
Figure 5. ControlSpace CC-16 Controller Exploded View .....	17
<b>Main Part List, ControlSpace™ CC-64 Controller</b> .....	18
Figure 6. ControlSpace CC-64 Controller Exploded View .....	18
<b>Electrical Part Lists</b> .....	19-64
<b>ESP-88 Chassis Motherboard PCB Assembly</b> .....	19-25
<b>ESP-88 Chassis 4x4 PCB Assembly</b> .....	26-42
<b>ESP-88 Digital Signal Processor (DSP) PCB Assembly</b> .....	43-56
<b>ESP-88 Output PCB Assembly</b> .....	57
<b>ESP-88 LED PCB Assembly</b> .....	57
<b>CC-64 Control Center</b> .....	58-62
<b>CC-16 Zone Controller</b> .....	63-64
<b>Disassembly Procedures</b> .....	65-67
<b>ControlSpace ESP-88 Chassis</b> .....	65
<b>ControlSpace CC-16 Control Center</b> .....	66
<b>ControlSpace CC-64 Control Center</b> .....	67
<b>Front Panel Indicators and Features</b> .....	68
<b>Rear Panel Controls and Connections</b> .....	69
<b>Test Procedures, Audio Processor ESP-88 Std Version</b> .....	71-96
Figure 7. ATS-2, ESP-88 and AuBit Switchbox Test Setup Diagram .....	73
Figure 8. Motherboard Top Etch Layout Diagram .....	97
Figure 9. Motherboard VCC Etch Layout Diagram .....	97
Figure 10. Motherboard GND Etch Layout Diagram .....	98
Figure 11. Motherboard Bottom Etch Layout Diagram .....	98
Figure 12. MIC/Line Input PCB Topside Etch Layout Diagram .....	99
Figure 13. MIC/Line Input PCB VCC Etch Layout Diagram .....	99
Figure 14. MIC/Line Input PCB GND Etch Layout Diagram .....	100
Figure 15. MIC/Line Input PCB Bottom Etch Layout Diagram .....	100
Figure 16. DSP PCB Topside Etch Layout Diagram .....	101
Figure 17. DSP PCB VCC Etch Layout Diagram .....	101
Figure 18. DSP PCB GND Etch Layout Diagram .....	102
Figure 19. DSP PCB Bottom Etch Layout Diagram .....	102
Figure 20. GPIO PCB Topside Etch Layout Diagram .....	103
Figure 21. GPIO PCB VCC Etch Layout Diagram .....	103
Figure 22. GPIO PCB GND Etch Layout Diagram .....	103
Figure 23. GPIO PCB Bottom Etch Layout Diagram .....	103
Figure 24. Output PCB Topside Etch Layout Diagram .....	104
Figure 25. Output PCB Bottom Etch Layout Diagram .....	104
Figure 26. LED PCB Topside Etch Layout Diagram .....	104
Figure 27. LED PCB Bottom Etch Layout Diagram .....	104
<b>Power Supply +5VDC Voltage Adjustment Procedures</b> .....	105-106
<b>Troubleshooting</b> .....	107
<b>Service Manual Revision History</b> .....	108

# SAFETY INFORMATION

1. Parts that have special safety characteristics are identified by the  symbol on schematics or by special notes on the parts list. Use only replacement parts that have critical characteristics recommended by the manufacturer.
2. Make leakage current or resistance measurements to determine that exposed parts are acceptably insulated from the supply circuit before returning the unit to the customer. Use the following checks to perform these measurements:

**A. Leakage Current Hot Check-**With the unit completely reassembled, plug the AC line cord directly into a 120V AC outlet. (Do not use an isolation transformer during this test.) Use a leakage current tester or a metering system that complies with American National Standards Institute (ANSI) C101.1 "Leakage Current for Appliances" and Underwriters Laboratories (UL) UL6500 / UL60065 / IEC 60065 paragraph 9.1.1. With the unit AC switch first in the ON position and then in OFF position, measure from a known earth ground (metal waterpipe, conduit, etc.) to all exposed metal parts of the unit (antennas, handle bracket, metal cabinet, screwheads, metallic overlays, control shafts, etc.), especially any exposed metal parts that offer an electrical return path to the chassis. Any current measured must not exceed 0.5 milliamp. Reverse the unit power cord plug in the outlet and repeat test. **ANY MEASUREMENTS NOT WITHIN THE LIMITS SPECIFIED HEREIN INDICATE A POTENTIAL SHOCK HAZARD THAT MUST BE ELIMINATED BEFORE RETURNING THE UNIT TO THE CUSTOMER.**

**B. Insulation Resistance Test Cold Check-**(1) Unplug the power supply and connect a jumper wire between the two prongs of the plug. (2) Turn on the power switch of the unit. (3) Measure the resistance with an ohmmeter between the jumpered AC plug and each exposed metallic cabinet part on the unit. When testing 3 wire products, the resistance measured to the product enclosure should be between 2 and infinite MOhms. Also, the resistance measured to exposed input/output connectors should be between 4 and infinite MOhms. When testing 2 wire products, the resistance measured to exposed input/output connectors should be between 4 and infinite MOhms. If it is not within the limits specified, there is the possibility of a shock hazard, and the unit must be repaired and rechecked before it is returned to the customer.

**CAUTION: The Bose® ControlSpace® ESP-88 System, CC-16 and CC-64 Controllers contains no user-serviceable parts. To prevent warranty infractions, refer servicing to warranty service stations or factory service.**

## PROPRIETARY INFORMATION

THIS DOCUMENT CONTAINS PROPRIETARY INFORMATION OF BOSE CORPORATION WHICH IS BEING FURNISHED ONLY FOR THE PURPOSE OF SERVICING THE IDENTIFIED BOSE PRODUCT BY AN AUTHORIZED BOSE SERVICE CENTER OR OWNER OF THE BOSE PRODUCT, AND SHALL NOT BE REPRODUCED OR USED FOR ANY OTHER PURPOSE.

## WARRANTY

The Bose ControlSpace ESP-88 System and CC-16 and CC-64 Controllers are covered by a limited 5-year transferable warranty.

# PRODUCT DESCRIPTION

## ESP-88 Chassis Overview:

The Bose® ControlSpace® ESP-88 engineered sound processor is a flexible, expandable and high quality audio signal processor for engineered sound applications such as churches, theaters, auditoriums, and sports venues.

The base model (ESP-88) includes eight inputs (microphone or line-level selectable) and eight line level outputs. Four available audio slots allow the addition of up to 16 more analog audio channels – inputs, outputs or a combination – or up to 32 more digital audio channels (AES3) as inputs, outputs or a combination.

For large applications, multiple ESP-88s can be used per system. Multiple choices of user controllers are available to provide end-users with simple, easy-to-use control of their ControlSpace system.

The Bose ControlSpace Designer software is used to design systems and configure the ESP-88 and user controllers. The software runs on a PC and communicates to the ESP-88 over Ethernet.

Features and functions:

- Expandable and flexible cardframe architecture
- Eight mic/line analog audio input channels
- Eight line level analog audio output channels
- Four open audio expansion slots allow up to 32 analog audio channels total in a 2U chassis
- DSP expansion slot allows DSP processing power and delay times to increase fourfold
- Eight general purpose control inputs and eight general purpose control outputs (GPIO)
- GPIO expansion slot allows up to 16 control inputs and 16 control outputs
- All audio input and input channels feature tricolor level LEDs
- Design, control and configuration via PCbased software and Ethernet connection.
- Large set of signal processing modules including: Bose speaker EQs, Bose crossovers, graphic and parametric EQs, routers, delays, matrix mixers, signal generators, meters, compressors/Limiters, duckers, automatic gain controls, gate and source selectors.

## Modularity and Expansion

### Flexible Architecture

The ESP-88 employs a flexible, modular architecture. The flexible architecture provides two levels of DSP performance – up to 32 general-purpose I/O and up to 64 digital audio channels – or up to 32 analog audio channels.

The base model ESP-88, includes a DSP card, two 4x4 Mic/Line cards and one GPIO card. In this configuration, four audio and one GPIO slot are available for expansion.

Three types of optional cards are available: DSP expansion; GPIO; and Audio.

DSP Expansion Card - Daughter card for main DSP card. Increases performance by 300%. One card can be added to an ESP-88.

### GPIO Card

Fits in one of the two GPIO slots. Eight control inputs and eight control outputs. One GPIO card can be added to an ESP-88.

# PRODUCT DESCRIPTION

## ESP-88 Chassis Overview (continued):

### Optional Cards

#### Audio Cards:

4x4 Mic/Line Card (Series I)

4x4 Mic/Line Card (Series II)

Occupies two audio slots. Four microphone or line level inputs (software selectable), and four line level outputs. The ESP-88 includes two 4x4 Mic/line cards. Two 4x4 cards can be added.

#### EDR Line Level Output Card

Occupies one audio slot. Four highest-quality, line level outputs.

#### EDR Line Level Input Card

Occupies one audio slot. Four highest-quality, line level inputs.

#### AES3 Output Card

Occupies one audio slot. Eight AES3 outputs (two per output connector).

#### AES3 Input Card

Occupies one audio slot. Eight AES3 inputs (two per input connector).

#### Surround Sound Card

Occupies one audio slot. One optical and one coaxial digital audio inputs.

### ESP-88 Inside View

(Shown with optional DSP daughter card)

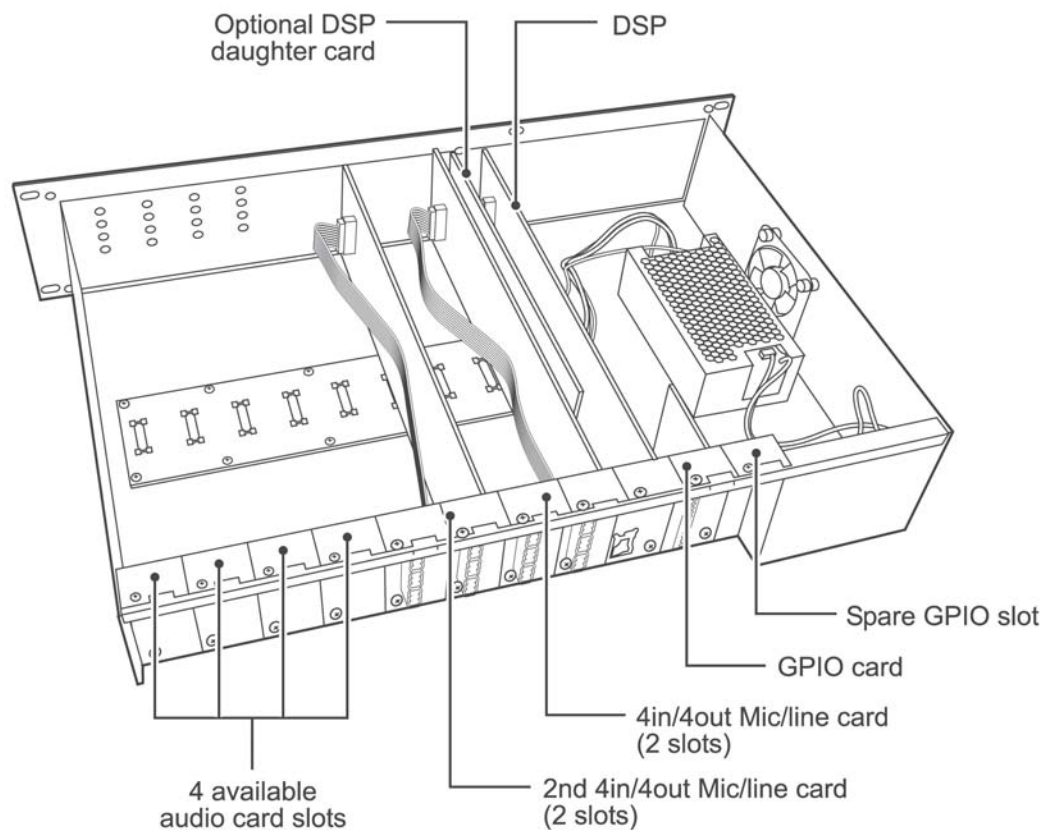

# PRODUCT DESCRIPTION

## CC-16 Zone Controller



The Bose® ControlSpace® CC-16 zone controller is an elegant wall-mounted device designed to provide end-user control of ControlSpace systems. Custom programming allows the CC-16 to control a variety of the system elements, from switching audio sources to selecting “scenes” or system configurations. The CC-16 features a bitmap LCD and four buttons for displaying and controlling the system settings.

The CC-16 connects to the ControlSpace Engineered Sound Processor (ESP-88) at the RS-485 port. Up to fifteen CC-16 units can be used per each ESP-88 to provide localized control of the system. The maximum distance from ESP-88 to CC-16 is 2000 feet. As a networked device, remote reprogramming is possible at any time.

### Features and Functions

- 122 x 32 pixel backlit blue LCD
- LCD displays volume level and source/scene/preset setting
- Select up/down buttons for selecting sources or scenes
- Volume up/down buttons for controlling one or more gain controls
- IR receiver (for IR remote controls)
- RS-485 network supports up to fifteen CC-16 units per ESP-88
- DIP-switch for specifying network address and termination
- Universal mounting bracket
- UL and CE listed

## CC-64 Control Center



The Bose ControlSpace CC-64 control center is an elegant, programmable, networked controller that provides users with a simple and logical interface to their ControlSpace system. Because the controller is completely programmable, you can customize the ControlSpace system, making only certain controls available, and simplifying user interaction with the system.

The CC-64 provides four rotary encoders with circular LED arrays for a userfriendly method of managing gain settings or scene selections. A fifth encoder provides control over programmed “scenes” or presets. Four bank switch buttons redefine the four Gain/Selector control knobs, providing quick access for up to 16 system gain controls or selectors. A large, 2-line by 40-character backlit LCD provides the user with the names of the system elements they are controlling (gains, presets, etc.).

Using custom programming, the CC-64 can manage a variety of system elements, including audio sources, scene selection settings, and specific system configurations. Each gain control can be ganged so that a single control can be mapped to as many as sixteen system gains. The CC-64 also supports a “custom mode” – intended for installers, not end users – in which any parameter in the system can be viewed and changed using the LCD display and control knobs.



# PRODUCT DESCRIPTION

## CC-64 Control Center (continued)

The CC-64 is a 10Base-T Ethernet device. Up to sixteen CC-64s can be used per ControlSpace® system.

### Features

- 2-line by 40-character backlit LCD
- Sixteen Gain/Selector controls (four banks of four)
  - Four rotary encoders for changing the gain level or selecting scenes/sources
  - Each encoder includes a 15-segment LED array for indicating the control's current level or state
  - The encoders feature push buttons for muting gain controls or making selections
  - Ten character descriptions of the gain controls appear on the LCD above the encoder
- Four bank switch buttons with label area
- Lock function in software prevents local changes
- 10Base-T Ethernet network based
- Sixteen CC-64s per ControlSpace system
- Power over Ethernet cable or separate cable
- LEDs for status, link and network transmit/receive
- Fits standard 5-gang electrical box
- UL6500 listed and CE approved

### Functions

1. LCD
2. Preset/Scene selector
  - Rotate to view presets. Push to select.
  - Push and hold for 5 seconds to enter Custom mode.
3. Network link indicator
4. Network receive indicator
5. Network transmit indicator
6. Bank select buttons (4). Press to select one of four bank controls
7. Bank select indicators (4). Indicates the currently selected bank
8. Bank select label area. 1.25" (31.75 mm) x .35" (9 mm) area for custom labels.
  - Accepts standard 3/8" (9 mm) label stock.
9. Gain/Selector control knob. Rotary encoder (no stops). Push to mute.
10. Gain/Selector level indicators (15 levels/selections)

# SPECIFICATIONS

## Inputs

<b>Type:</b>	8 analog, electronically balanced, microphone/line level (software selectable)
<b>Connectors:</b>	Phoenix/Euroblock 2-piece, 3-pin
<b>Nominal Input Level:</b>	+4dBu/-10dBu/-20dBu/-38dBu/-44dBu/-50dBu/-60dBu
<b>Frequency Response:</b>	20 to 20kHz (+0.5dB / -2.0dB) at +4dBu nominal input level
<b>Input Impedance:</b>	2.4k ohm @ 1kHz (with or without phantom power active)
<b>Maximum Input Level:</b>	+24dBu @ +4dBu nominal input power
<b>Equivalent Input Noise:</b>	-115dB at -60dBu nominal input level (A-weighted/20-20kHz)
<b>Phantom Power:</b>	+15V nominal, selectable per input
<b>THD+N:</b>	0.01% at +4dBu nominal input and output level (A-weighted/20-20kHz)
<b>Digital Resolution:</b>	24-bit

## Outputs

<b>Type:</b>	8 analog, electronically balanced
<b>Connectors:</b>	Phoenix/Euroblock 2-piece, 3-pin
<b>Nominal Output Level:</b>	+4dBu
<b>Output Impedance:</b>	200 Ohms (600 Ohm load expected)
<b>Frequency Response:</b>	20 to 20kHz (+0.5dB/-2.0dB) at +4dBu nominal output level
<b>Maximum Output Level:</b>	+24dBu at +4dBu nominal output level
<b>Digital Resolution:</b>	24-bit
<b>Signal to Noise Ratio (SNR):</b>	80dB at +4dBu nominal output level (A-weighted/20-20kHz)
<b>Residual Output Noise:</b>	-110dBu at output muted (A-weighted/20-20kHz)
<b>THD+N:</b>	0.01% at +4dBu nominal input and output level (A-weighted/20-20kHz)
<b>Crosstalk:</b>	< -90dB at +4dBu nominal input and output level at 1kHz



# SPECIFICATIONS

## Signal Processing

<b>Type:</b>	32-bit floating-point digital signal processor(s)
<b>Clock Speed:</b>	200MHz
<b>Maximum Calculation:</b>	1600 MIPS/1200 MFLOPS (6400 MIPS/4800 MFLOPS with DSP option card)
<b>Delay Memory:</b>	16MByte/72s (maximum) (64MByte/288s maximum with DSP option card)
<b>Audio Latency:</b>	610us (analog in to analog out) (860us with DSP option card)
<b>Sampling Rate:</b>	48kHz

## Control Inputs

<b>Type:</b>	8 analog or digital inputs, 5.1k ohms internal pull-up resistor to 5V
<b>Connectors:</b>	Phoenix/Euroblock 2-piece, 9-pin 3.81mm pitch
<b>Analog Input:</b>	0V to 3.3V (max 5V; suitable for 10k ohm variable resistor)
<b>Digital Input Voltage Range:</b>	0V to 3.3V (threshold voltage = 1.6V; internal 5.1k ohms pulled up to 5V)

## Control Outputs

<b>Type:</b>	8 digital outputs, 10k ohms internal pull-up resistors to 5V
<b>Connectors:</b>	Phoenix/Euroblock 2-piece, 9-pin 3.81mm pitch
<b>Output Voltage:</b>	0V to 5V open collector
<b>Output Current:</b>	0.5mA (source)/10mA max (sink)

## Communication Ports

<b>LAN:</b>	10Base-T (RJ-45)
<b>RS-232C:</b>	D-sub 9 pin, male; DTE
<b>RS-485:</b>	Phoenix/Euroblock 2-piece, 3-pin

## Indicators

<b>Status:</b>	Power/Status/Ethernet/Serial (RS232C + RS485)
<b>Audio:</b>	Signal (Present/Normal/Clip) for each audio input and output

# SPECIFICATIONS

## Expansion Slots

<b>Audio I/O:</b>	8 slots (4 slots occupied)
<b>Control I/O:</b>	2 slots (1 slot occupied) Max 16 inputs/16 outputs
<b>DSP:</b>	1 slot

## Audio Channels

<b>Analog:</b>	32 max (all slots full)
<b>Digital (AES3):</b>	64 (all slots full)

## Mechanical

<b>Dimensions:</b>	18.9"W x 3.5"H x 12.6"D (482 x 88 x 320mm)
<b>Weight:</b>	14 lb. (5.3 kg)

## Electrical

<b>Mains Voltage:</b>	85 - 264 VAC 50/60 Hz with PFC
<b>Power Consumption:</b>	< 35VA
<b>Maximum Power Consumption:</b>	< 70VA (at <35 degrees C ambient)

## Environmental

<b>Operating Temperature:</b>	< 50 degrees C at less than 35VA / < 40 degrees C at less than 70VA
<b>Humidity:</b>	80% relative humidity (without condensation)

Dimensions

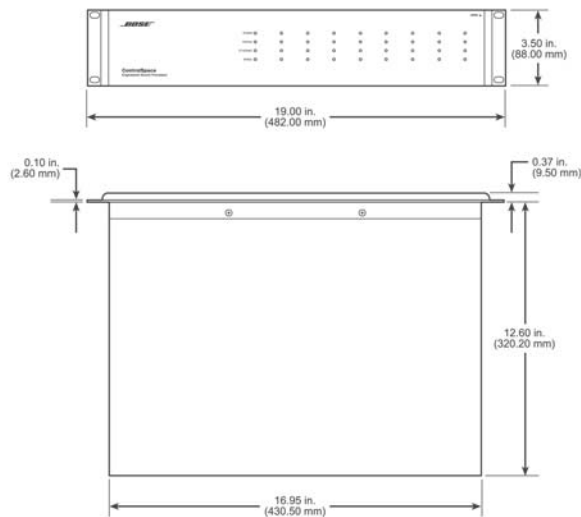

# ELECTROSTATIC DISCHARGE SENSITIVE (ESDS) DEVICE HANDLING

This unit contains ESDS devices. We recommend the following precautions when repairing, replacing or transporting ESDS devices:

- Perform work at an electrically grounded work station.
- Wear wrist straps that connect to the station or heel straps that connect to conductive floor mats.
- Avoid touching the leads or contacts of ESDS devices or PC boards even if properly grounded. Handle boards by the edges only.
- Transport or store ESDS devices in ESD protective bags, bins, or totes. Do not insert unprotected devices into materials such as plastic, polystyrene foam, clear plastic bags, bubble wrap or plastic trays.

## PART LIST NOTES

1. This part is not normally available from Customer Service. Approval from the Field Service Manager is required before ordering.
2. The individual parts located on the PCBs are listed in the Electrical Part List.
3.  This part is critical for safety purposes. Failure to use a substitute replacement with the same safety characteristics as the recommended replacement part might create shock, fire and/or other hazards.
4. This part is referenced for informational purposes only. It is not stocked as a repair part. Refer to the next higher assembly for a replacement part.

# PACKAGING PART LIST

ControlSpace® ESP-88 Chassis

Item Number	Description	Qty.	Part Number	Note
1	EPE FOAM	2	312474	
2	ESP-88 Chassis, US/CAN ESP-88 Chassis, EURO ESP-88 Chassis, UK ESP-88 Chassis, JAPAN ESP-88 Chassis, AUS	1	041755 041756 041758 041757 041759	
3	POLYBAG, L550xW600MM	1	-	4
4	CONTROLSPACE S/W CD	1	-	4
5	CD SLEEVE	1	-	4
6	POLYBAG, L300xW150MM	1	-	4
7	POWER CORD, 120V, US/CAN POWER CORD, 220V, EURO POWER CORD, 240V, UK POWER CORD, 100V, JAPAN POWER CORD, 240V, AUS	1	298165 298166 298168 298167 298169	3 
8	CAT-5 ETHERNET CABLE	1	-	4
9	POLYBAG, 100x60MM	3	-	4
10	TERMINAL BLOCK, 9 POS	2	305532	
11	TERM BLOCK, PLUG, ORANGE	8	305536	
12	TERM BLOCK, PLUG, GREEN	9	305535	
13	USER MANUAL	1	275800	
14	CARTON	1	275797	

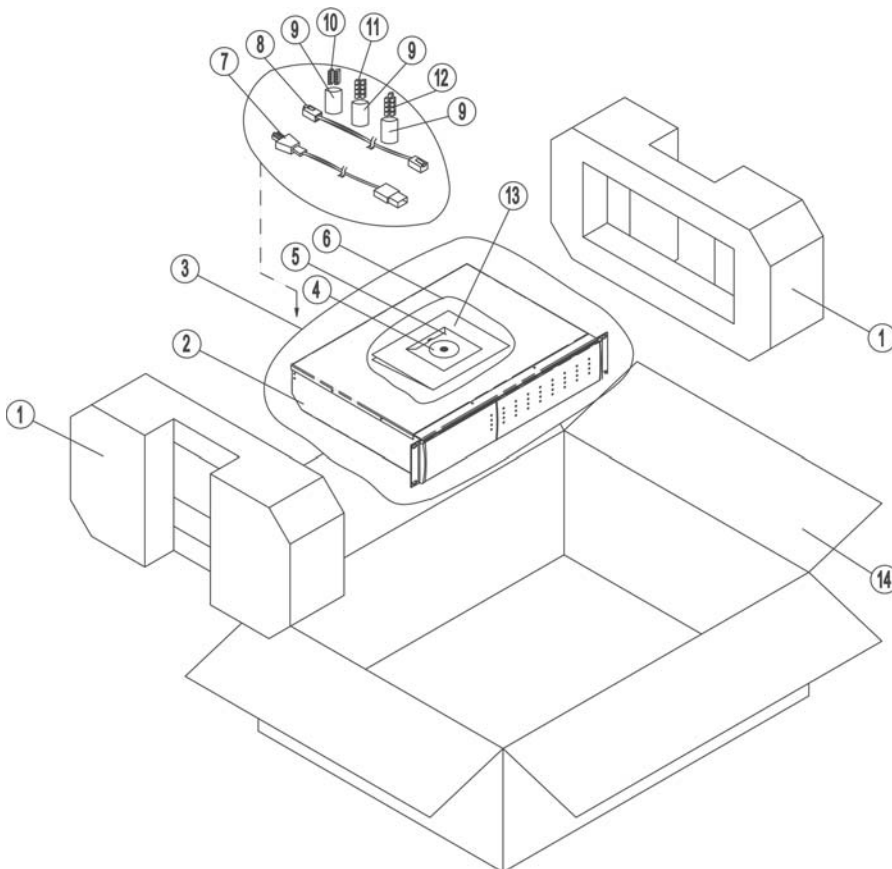

Figure 1. ESP-88 Chassis Packing View

# PACKAGING PART LIST

ControlSpace® CC-16 Controller

Item Number	Description	Qty.	Part Number	Note
1	Foam, White EPE	1	-	4
2	CC-16 Controller	1	041761	2
3	Anti-static bag, 150 x 180 x 0.03MM	1	-	4
4	Paper Tray	1	-	4
5	Installation Manual, English Language	1	285042	
6	White box	1	-	4
7	Screw, #6-32x0.7", Phillips, ZINC (US/Japan)	4	-	4
8	Bag, Poly, 40 x 60MM	2	-	4
9	Screw, M4.0x18, Phillips, ZINC (Europe)	4	-	4
-	Power Supply, 15VDC, 5W, 100-240VAC Input (not packaged w/CC-16)	1	041762	3

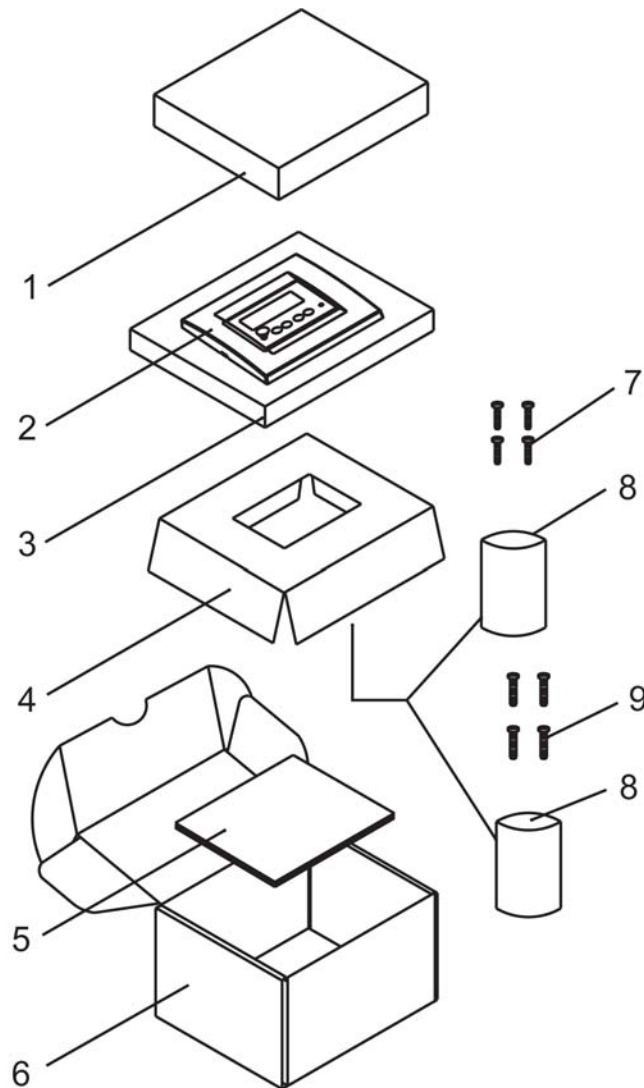

Figure 2. CC-16 Controller Packing View

# PACKAGING PART LIST

ControlSpace® CC-64 Controller

Item Number	Description	Qty.	Part Number	Note
1	Install Guide, CC-64	1	285041	
2	EPE Foam, 330X180X15MM	1	-	4
3	Bag, PE, Anti-Static, 330X180X0.03MM	1	-	4
4	CC-64 Controller	1	041760	2
5	Screw, US, MSF, #6-32X0.7, MS, ZN-WH	4	-	4
6	Bag, Poly, 40X60MM	1	-	4
7	Tray, Foam, EPE, 330x180x45MM	1	-	4
8	Terminal Block, 2P, P5.08, 2ESDV-02P	1	-	4
9	Bag, Poly, 100X60MM	1	-	4
10	White Box, W9B	1	-	4
11	Computer UTP LAN Cable, 2M, CAT 5	1	-	4
-	Power Supply, 15VDC, 5W, 100-240VAC Input (not packaged w/CC-64)	1	041762	3

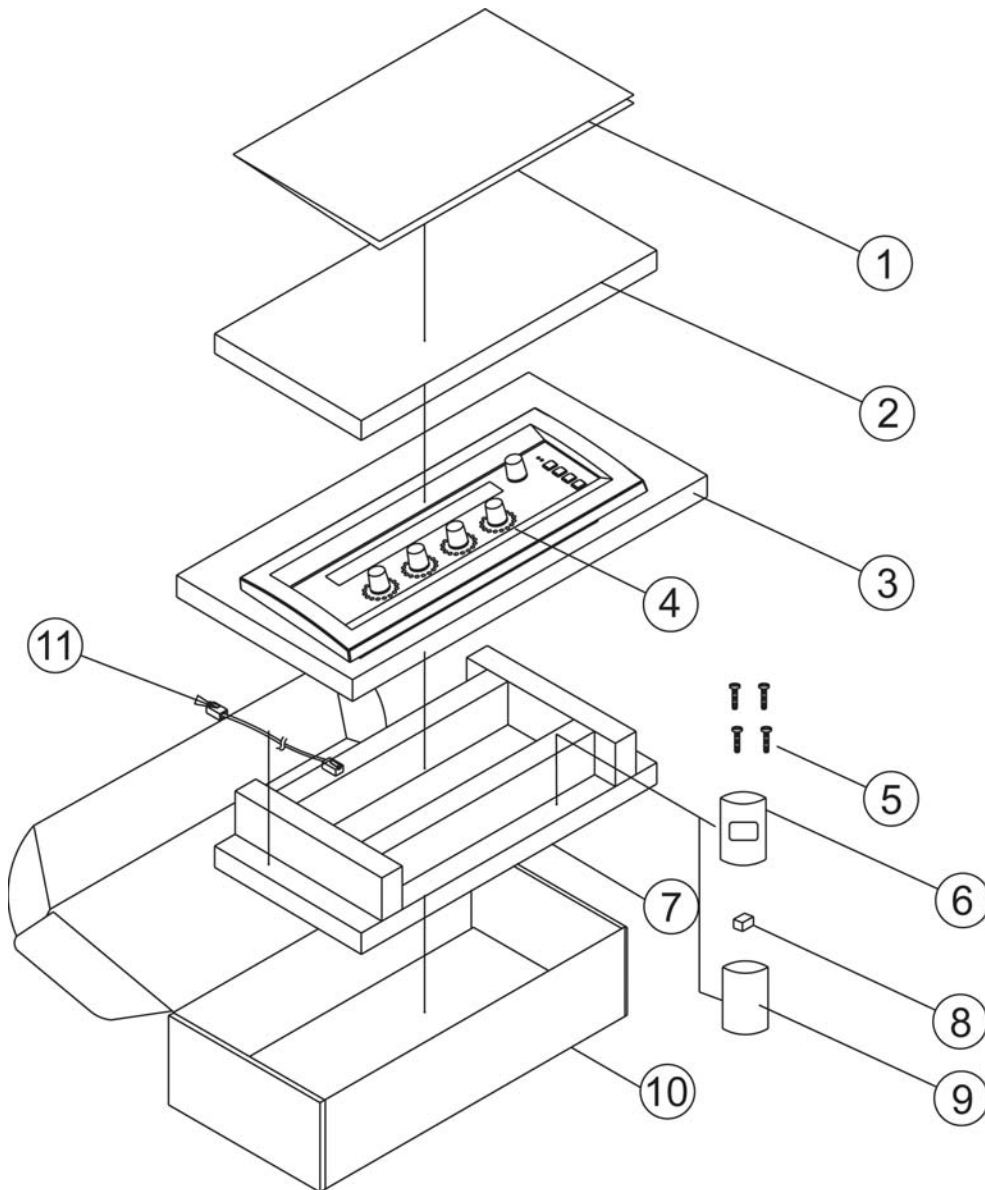



Figure 3. CC-64 Controller Packing View



# MAIN PART LIST

ControlSpace® ESP-88 Chassis (see Figure 4)

Item Number	Description	Qty.	Part Number	Note
1	TOP COVER	1	278505-001	
2	M3x4 SCREW, MSF, MS-BK (FOR CHASSIS/COVER)	4	-	4
3	M3x4 SCREW, SI, MSB, MS-BK	62	-	4
4	GIO REAR PANEL, SECC-T1, T=1.0MM	1	278516-001	
5	PANEL, REAR, BLANK, SECC-T1 T=1.0MM	5	278518-001	
6	DSP REAR PANEL, SECC-T1, T=1.0MM	1	278515-001	
7	4CH REAR PANEL (LINE OUTPUT) SECC-T1 T=1.0MM	2	278512-003	
8	4CH REAR PANEL (MIC/LINE INPUT) SECC-T1 T=1.0MM	2	278512-002	
9	4x4 LINE OUTPUT PCB ASSY (PART OF ITEM 10 BELOW)	2	-	
10	4X4 MIC/LINE SERIES I I/O PCB	2	041767	2
	4X4 MIC/LINE SERIES II I/O PCB		041915	
11	PCB FIXED STICK, ABOVE	2	278503-001	
12	MOTHERBOARD PCB ASSY	1	275796	2
13	M3x6 SCREW, MSB, M3x6mm, MS-BK	5	-	4
14	INTERNAL TOOTH WASHER, OD 6.4xID3xT0.45MM	7	-	4
15	LED LENS, PMMA, MF001	9	278522-001	
16	FRONT ENDCAP, RIGHT, PC/ABS, C2950 (M3x3 NUT)	1	278521-002	
17	DOOR, ALUMINUM	1	278520-001	
18	FRONT PANEL, ALUM, FIXED	1	278519-001	
19	FRONT ENDCAP, MID, PC/ABS, C2950, (M3x2 NUT)	1	278521-003	
20	FRONT ENDCAP, LEFT, PC/ABS, C2950 (M3x3 NUT)	1	278521-001	
21	FRONT PANEL, SECC-T1	1	278507-001	
22	CHASSIS	1	278506-001	
23	PCB FIXED STICK, BELOW	1	278504-001	
24	SCREW, US, MSF, 4#-40x0.236, MS, BLACK	4	-	4
25	LED PCB ASSEMBLY (PART OF MIC/LINE IN/OUT MAIN PCB)	2	-	2
26	POWER SUPPLY, 70W, REL-70-3002- F-CHCO	1	295622	 3
27	M4x12 SCREW, SI, MSB, MS-BK (FOR FAN)	4	-	4
28	DC FAN, +5VDC, 60MM, F6010AP-05LCW	1	295621	 3
29	M4x3 HEX NUT W/NYLON INSERT, SI, SS	4	-	4
30	DSP PCB ASSEMBLY	1	275794	2
31	GPIO PCB ASSEMBLY	1	041768	2
32	STAY, SECC-T1, T=1.0MM	1	278508-001	
-	DSP EXPANSION CARD	-	041769	
-	8-CH DIGITAL IN EXP PCB	-	041765	
-	8-CH DIGITAL OUT EXP PCB	-	041766	
-	4-CH ANALOG IN EXP PCB (EDR Line Level Input Card)	-	041764	

# MAIN PART LIST

ControlSpace® ESP-88 Chassis (continued)

Item Number	Description	Qty.	Part Number	Note
-	4-CH ANALOG OUT EXP PCB (EDR Line Level Output Card)	-	041763	
-	4-CH SDR OUTPUT PCB	-	041916	
-	4-CH MIC/LINE INPUT PCB	-	041917	
-	SURROUND DECODER INPUT PCB	-	302210	
-	AC POWER SWITCH, ROCKER, SPST, 125V/15A	1	-	⚠ <sup>3, 4</sup>
-	AC SOCKET, IEC, 250V/10A	1	-	⚠ <sup>3, 4</sup>
-	Power Supply Harness, Improved, ESP-88C / ESP-00 (used with the Astec power supply)	1	318935-001S	⚠ <sup>3</sup>
-	Power Supply Harness, Improved, ESP-88 / ESP-88C (used with the IPD power supply)	1	318938-001S	⚠ <sup>3</sup>

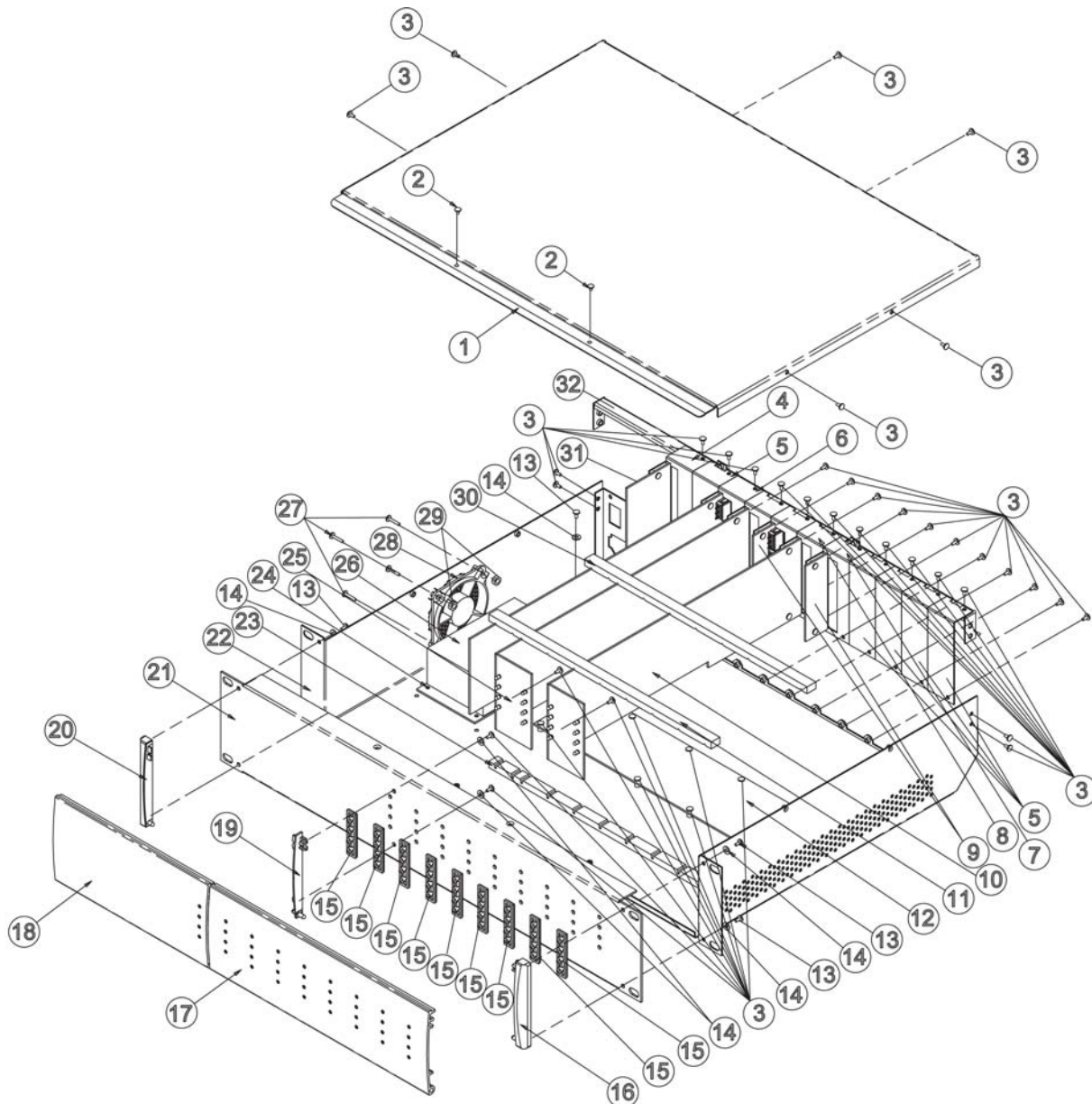

Figure 4. ControlSpace ESP-88 Chassis Exploded View

# MAIN PART LIST

ControlSpace® CC-16 Controller

Item Number	Description	Qty.	Part Number	Note
1	Front plate, PC, GE, LEXAN, 241R, White	1	275432	
2	Overlay, PC sheet, w/adhesive, 0.18mm	1	277488	
3	Insert, plate, PC, GE, LEXAN, 241R, White	1	275434	4
4	LCD PCB Assembly	1	275817-002	
5	Mounting Frame, PC, GE, LEXAN, 241R, White	1	275433	4
6	Main PCB Assembly	1	275817-001	

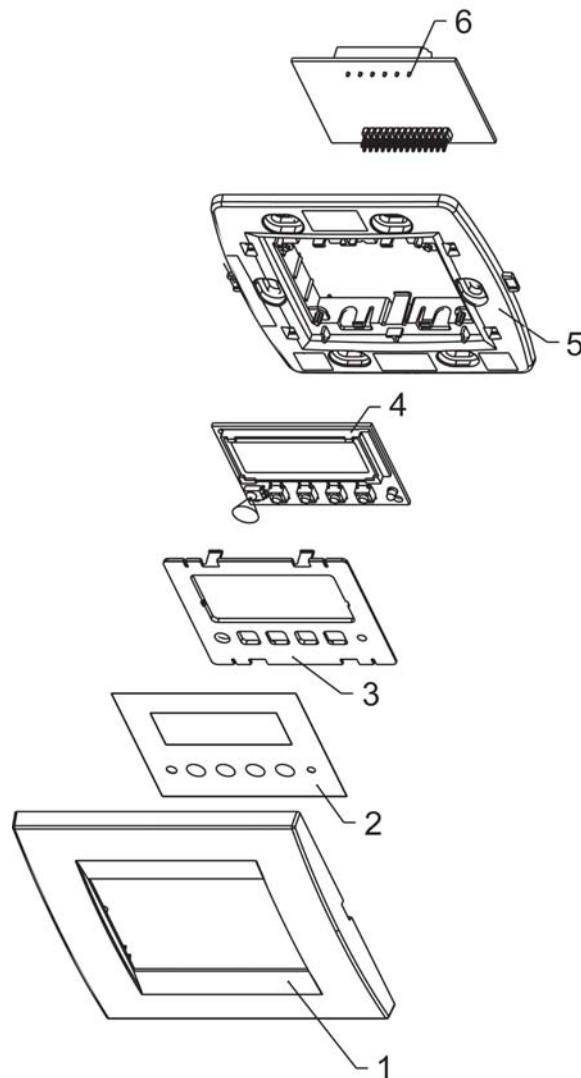

Figure 5. ControlSpace CC-16 Controller Exploded View

# MAIN PART LIST

ControlSpace® CC-64 Controller

Item Number	Description	Qty	Part Number	Note
1	Metal EMC Shield, Case, SECC-T1, T=0.50MM	1	275816	4
2	Front Panel	1	275814	4
3	Knob	5	278523-002	
4	Nylon Washer, OD=6.1MM, ID=2.95MM, T=2MM	6	-	4
5	Keyboard Overlay, Plastic, W/S, Adhesive	1	277485	
6	LCM Module, STN, Blue, 12 Clock, YMC402-11AAABUCL	1	323977-001S	
7	LED PCB Assembly	1	278524-001	
8	Main PCB Assembly	1	278523-001	
9	Metal Panel, Aluminum	1	275815	4
10	Screw, SI, MSP, M3X11.5MM	4	-	4
11	Screw, MSB, M3X6, NI	14	-	4
12	Spacer, Support, K33-7	4	-	4
13	Sponge	1	-	4
14	PVC Washer, ID=3.1MM, T=0.3MM	4	-	4

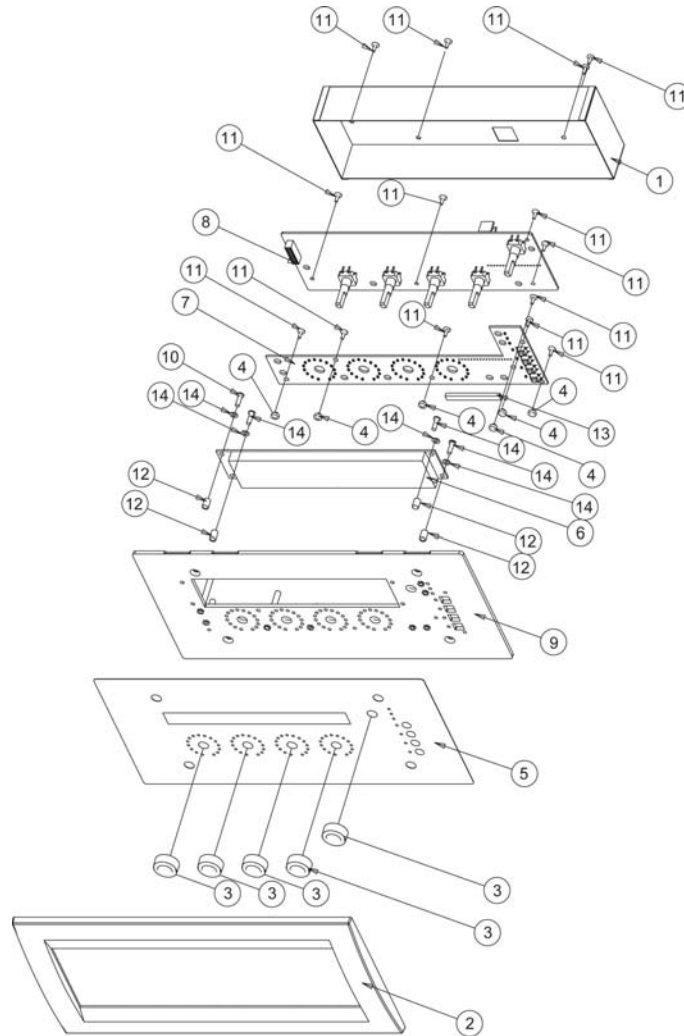

Figure 6. ControlSpace CC-64 Controller Exploded View

# ELECTRICAL PART LIST

ESP-88 Chassis Motherboard PCB Assembly

Resistors

Reference Designator	Description	Vendor	Vendor Part Number	Note
JP200	0 OHM, 0603, 1/10W, 5%	Yageo	RC0603JR-07R00	4
JP201	0 OHM, 0603, 1/10W, 5%	Yageo	RC0603JR-07R00	4
JP202	0 OHM, 0603, 1/10W, 5%	Yageo	RC0603JR-07R00	4
JP203	0 OHM, 0603, 1/10W, 5%	Yageo	RC0603JR-07R00	4
R100	10K, 0603, 1/10W, 1%	Yageo	RC0603FR-0710K	4
R101	1K, 0603, 1/10W, 1%	Yageo	RC0603FR-071K	4
R102	0 OHM, 0603, 1/10W, 5%	Yageo	RC0603JR-07R00	4
R103	0 OHM, 0603, 1/10W, 5%	Yageo	RC0603JR-07R00	4
R104	0 OHM, 0603, 1/10W, 5%	Yageo	RC0603JR-07R00	4
R105	0 OHM, 0603, 1/10W, 5%	Yageo	RC0603JR-07R00	4
R200	220K, 0603, 1/10W, 1%	Yageo	RC0603FR-07220K	4
R201	8.2K, 0603, 1/10W, 1%	Yageo	RC0603FR-078K2	4
R202	12K, 0603, 1/10W, 1%	Yageo	RC0603FR-0712K	4
R204	10K, 0603, 1/10W, 1%	Yageo	RC0603FR-0710K	4
R205	2.2K, 0603, 1/10W, 1%	Yageo	RC0603FR-072K2	4
R208	0 OHM, 0603, 1/10W, 5%	Yageo	RC0603JR-07R00	4
R209	0 OHM, 0603, 1/10W, 5%	Yageo	RC0603JR-07R00	4
R210	0 OHM, 0603, 1/10W, 5%	Yageo	RC0603JR-07R00	4
R211	1K, 0603, 1/10W, 1%	Yageo	RC0603FR-071K	4
R213	1K, 0603, 1/10W, 1%	Yageo	RC0603FR-071K	4
R214	10K, 0603, 1/10W, 1%	Yageo	RC0603FR-0710K	4
R215	10K, 0603, 1/10W, 1%	Yageo	RC0603FR-0710K	4
R216	10K, 0603, 1/10W, 1%	Yageo	RC0603FR-0710K	4
R220	2.2K, 0603, 1/10W, 1%	Yageo	RC0603FR-072K2	4
R221	2.2K, 0603, 1/10W, 1%	Yageo	RC0603FR-072K2	4
R236	220K, 0603, 1/10W, 1%	Yageo	RC0603FR-07220K	4
R238	10K, 0603, 1/10W, 1%	Yageo	RC0603FR-0710K	4
R239	2.2K, 0603, 1/10W, 1%	Yageo	RC0603FR-072K2	4
R240	8.2K, 0603, 1/10W, 1%	Yageo	RC0603FR-078K2	4
R241	12K, 0603, 1/10W, 1%	Yageo	RC0603FR-0712K	4
R300	33 OHM, 0603, 1/10W, 1%	Yageo	RC0603FR-0733R	4
R301	33 OHM, 0603, 1/10W, 1%	Yageo	RC0603FR-0733R	4
R302	33 OHM, 0603, 1/10W, 1%	Yageo	RC0603FR-0733R	4
R303	33 OHM, 0603, 1/10W, 1%	Yageo	RC0603FR-0733R	4
R304	33 OHM, 0603, 1/10W, 1%	Yageo	RC0603FR-0733R	4
R305	33 OHM, 0603, 1/10W, 1%	Yageo	RC0603FR-0733R	4
R306	33 OHM, 0603, 1/10W, 1%	Yageo	RC0603FR-0733R	4
R307	33 OHM, 0603, 1/10W, 1%	Yageo	RC0603FR-0733R	4
R308	33 OHM, 0603, 1/10W, 1%	Yageo	RC0603FR-0733R	4
R309	33 OHM, 0603, 1/10W, 1%	Yageo	RC0603FR-0733R	4
R310	33 OHM, 0603, 1/10W, 1%	Yageo	RC0603FR-0733R	4
R311	33 OHM, 0603, 1/10W, 1%	Yageo	RC0603FR-0733R	4
R312	33 OHM, 0603, 1/10W, 1%	Yageo	RC0603FR-0733R	4
R313	33 OHM, 0603, 1/10W, 1%	Yageo	RC0603FR-0733R	4
R314	33 OHM, 0603, 1/10W, 1%	Yageo	RC0603FR-0733R	4
R315	33 OHM, 0603, 1/10W, 1%	Yageo	RC0603FR-0733R	4
R316	33 OHM, 0603, 1/10W, 1%	Yageo	RC0603FR-0733R	4



# ELECTRICAL PART LIST

ESP-88 Chassis Motherboard PCB Assembly

Resistors (continued)

Reference Designator	Description	Vendor	Vendor Part Number	Note
R317	33 OHM, 0603, 1/10W, 1%	Yageo	RC0603FR-0733R	4
R318	33 OHM, 0603, 1/10W, 1%	Yageo	RC0603FR-0733R	4
R319	33 OHM, 0603, 1/10W, 1%	Yageo	RC0603FR-0733R	4
R320	33 OHM, 0603, 1/10W, 1%	Yageo	RC0603FR-0733R	4
R321	33 OHM, 0603, 1/10W, 1%	Yageo	RC0603FR-0733R	4
R322	33 OHM, 0603, 1/10W, 1%	Yageo	RC0603FR-0733R	4
R323	33 OHM, 0603, 1/10W, 1%	Yageo	RC0603FR-0733R	4
R324	33 OHM, 0603, 1/10W, 1%	Yageo	RC0603FR-0733R	4
R325	33 OHM, 0603, 1/10W, 1%	Yageo	RC0603FR-0733R	4
R326	33 OHM, 0603, 1/10W, 1%	Yageo	RC0603FR-0733R	4
R327	33 OHM, 0603, 1/10W, 1%	Yageo	RC0603FR-0733R	4
R328	33 OHM, 0603, 1/10W, 1%	Yageo	RC0603FR-0733R	4
R329	33 OHM, 0603, 1/10W, 1%	Yageo	RC0603FR-0733R	4
R330	33 OHM, 0603, 1/10W, 1%	Yageo	RC0603FR-0733R	4
R331	33 OHM, 0603, 1/10W, 1%	Yageo	RC0603FR-0733R	4
R332	33 OHM, 0603, 1/10W, 1%	Yageo	RC0603FR-0733R	4
R333	33 OHM, 0603, 1/10W, 1%	Yageo	RC0603FR-0733R	4
R334	33 OHM, 0603, 1/10W, 1%	Yageo	RC0603FR-0733R	4
R335	33 OHM, 0603, 1/10W, 1%	Yageo	RC0603FR-0733R	4
R336	33 OHM, 0603, 1/10W, 1%	Yageo	RC0603FR-0733R	4
R337	33 OHM, 0603, 1/10W, 1%	Yageo	RC0603FR-0733R	4
R338	33 OHM, 0603, 1/10W, 1%	Yageo	RC0603FR-0733R	4
R339	33 OHM, 0603, 1/10W, 1%	Yageo	RC0603FR-0733R	4
R340	33 OHM, 0603, 1/10W, 1%	Yageo	RC0603FR-0733R	4
R341	33 OHM, 0603, 1/10W, 1%	Yageo	RC0603FR-0733R	4
R342	33 OHM, 0603, 1/10W, 1%	Yageo	RC0603FR-0733R	4
R343	33 OHM, 0603, 1/10W, 1%	Yageo	RC0603FR-0733R	4
R344	33 OHM, 0603, 1/10W, 1%	Yageo	RC0603FR-0733R	4
R345	33 OHM, 0603, 1/10W, 1%	Yageo	RC0603FR-0733R	4
R346	33 OHM, 0603, 1/10W, 1%	Yageo	RC0603FR-0733R	4
R347	33 OHM, 0603, 1/10W, 1%	Yageo	RC0603FR-0733R	4
R348	33 OHM, 0603, 1/10W, 1%	Yageo	RC0603FR-0733R	4
R349	33 OHM, 0603, 1/10W, 1%	Yageo	RC0603FR-0733R	4
R350	33 OHM, 0603, 1/10W, 1%	Yageo	RC0603FR-0733R	4
R351	33 OHM, 0603, 1/10W, 1%	Yageo	RC0603FR-0733R	4
R352	33 OHM, 0603, 1/10W, 1%	Yageo	RC0603FR-0733R	4
R353	33 OHM, 0603, 1/10W, 1%	Yageo	RC0603FR-0733R	4
R354	33 OHM, 0603, 1/10W, 1%	Yageo	RC0603FR-0733R	4
R355	33 OHM, 0603, 1/10W, 1%	Yageo	RC0603FR-0733R	4
R356	33 OHM, 0603, 1/10W, 1%	Yageo	RC0603FR-0733R	4
R357	33 OHM, 0603, 1/10W, 1%	Yageo	RC0603FR-0733R	4
R358	33 OHM, 0603, 1/10W, 1%	Yageo	RC0603FR-0733R	4
R359	33 OHM, 0603, 1/10W, 1%	Yageo	RC0603FR-0733R	4
R360	33 OHM, 0603, 1/10W, 1%	Yageo	RC0603FR-0733R	4
R361	33 OHM, 0603, 1/10W, 1%	Yageo	RC0603FR-0733R	4
R362	33 OHM, 0603, 1/10W, 1%	Yageo	RC0603FR-0733R	4
R363	33 OHM, 0603, 1/10W, 1%	Yageo	RC0603FR-0733R	4



# ELECTRICAL PART LIST

ESP-88 Chassis Motherboard PCB Assembly

Resistors (continued)

Reference Designator	Description	Vendor	Vendor Part Number	Note
R364	33 OHM, 0603, 1/10W, 1%	Yageo	RC0603FR-0733R	4
R365	33 OHM, 0603, 1/10W, 1%	Yageo	RC0603FR-0733R	4
R366	33 OHM, 0603, 1/10W, 1%	Yageo	RC0603FR-0733R	4
R367	33 OHM, 0603, 1/10W, 1%	Yageo	RC0603FR-0733R	4
R368	33 OHM, 0603, 1/10W, 1%	Yageo	RC0603FR-0733R	4
R369	33 OHM, 0603, 1/10W, 1%	Yageo	RC0603FR-0733R	4
R370	33 OHM, 0603, 1/10W, 1%	Yageo	RC0603FR-0733R	4
R371	33 OHM, 0603, 1/10W, 1%	Yageo	RC0603FR-0733R	4
R372	33 OHM, 0603, 1/10W, 1%	Yageo	RC0603FR-0733R	4
R373	33 OHM, 0603, 1/10W, 1%	Yageo	RC0603FR-0733R	4
R374	33 OHM, 0603, 1/10W, 1%	Yageo	RC0603FR-0733R	4
R375	33 OHM, 0603, 1/10W, 1%	Yageo	RC0603FR-0733R	4
R376	33 OHM, 0603, 1/10W, 1%	Yageo	RC0603FR-0733R	4
R377	33 OHM, 0603, 1/10W, 1%	Yageo	RC0603FR-0733R	4
R378	33 OHM, 0603, 1/10W, 1%	Yageo	RC0603FR-0733R	4
R379	33 OHM, 0603, 1/10W, 1%	Yageo	RC0603FR-0733R	4
R380	33 OHM, 0603, 1/10W, 1%	Yageo	RC0603FR-0733R	4
R381	33 OHM, 0603, 1/10W, 1%	Yageo	RC0603FR-0733R	4
R382	33 OHM, 0603, 1/10W, 1%	Yageo	RC0603FR-0733R	4
R383	33 OHM, 0603, 1/10W, 1%	Yageo	RC0603FR-0733R	4
R384	33 OHM, 0603, 1/10W, 1%	Yageo	RC0603FR-0733R	4
R385	33 OHM, 0603, 1/10W, 1%	Yageo	RC0603FR-0733R	4
R386	33 OHM, 0603, 1/10W, 1%	Yageo	RC0603FR-0733R	4
R387	33 OHM, 0603, 1/10W, 1%	Yageo	RC0603FR-0733R	4
R388	33 OHM, 0603, 1/10W, 1%	Yageo	RC0603FR-0733R	4
R389	33 OHM, 0603, 1/10W, 1%	Yageo	RC0603FR-0733R	4
R390	33 OHM, 0603, 1/10W, 1%	Yageo	RC0603FR-0733R	4
R391	33 OHM, 0603, 1/10W, 1%	Yageo	RC0603FR-0733R	4
R392	33 OHM, 0603, 1/10W, 1%	Yageo	RC0603FR-0733R	4
R393	33 OHM, 0603, 1/10W, 1%	Yageo	RC0603FR-0733R	4
R394	33 OHM, 0603, 1/10W, 1%	Yageo	RC0603FR-0733R	4
R395	33 OHM, 0603, 1/10W, 1%	Yageo	RC0603FR-0733R	4

## Resistor Arrays

Reference Designator	Description	Vendor	Vendor Part Number	Note
RA100	33 OHM, 8 PIN, 1/16W, ISO, 5%	Yageo	YC164-JR-0733R	4
RA101	33 OHM, 8 PIN, 1/16W, ISO, 5%	Yageo	YC164-JR-0733R	4
RA102	33 OHM, 8 PIN, 1/16W, ISO, 5%	Yageo	YC164-JR-0733R	4
RA103	33 OHM, 8 PIN, 1/16W, ISO, 5%	Yageo	YC164-JR-0733R	4
RA104	33 OHM, 8 PIN, 1/16W, ISO, 5%	Yageo	YC164-JR-0733R	4
RA105	33 OHM, 8 PIN, 1/16W, ISO, 5%	Yageo	YC164-JR-0733R	4
RA106	10K, 10 PIN, 8R, 1/16W, ISO, 5%	Yageo	YC158TJR-0710K	4

# ELECTRICAL PART LIST

ESP-88 Chassis Motherboard PCB Assembly

Capacitors

Reference Designator	Description	Vendor	Vendor Part Number	Note
C100	0.1uF, 0603, Y5V, 50V, 20%	Samsung	CL10F104ZBNC	4
C101	0.1uF, 0603, Y5V, 50V, 20%	Samsung	CL10F104ZBNC	4
C102	0.1uF, 0603, Y5V, 50V, 20%	Samsung	CL10F104ZBNC	4
C103	0.1uF, 0603, Y5V, 50V, 20%	Samsung	CL10F104ZBNC	4
C104	0.1uF, 0603, Y5V, 50V, 20%	Samsung	CL10F104ZBNC	4
C105	0.1uF, 0603, Y5V, 50V, 20%	Samsung	CL10F104ZBNC	4
C106	0.1uF, 0603, Y5V, 50V, 20%	Samsung	CL10F104ZBNC	4
C107	0.1uF, 0603, Y5V, 50V, 20%	Samsung	CL10F104ZBNC	4
C108	0.1uF, 0603, Y5V, 50V, 20%	Samsung	CL10F104ZBNC	4
C109	0.1uF, 0603, Y5V, 50V, 20%	Samsung	CL10F104ZBNC	4
C110	0.1uF, 0603, Y5V, 50V, 20%	Samsung	CL10F104ZBNC	4
C111	0.1uF, 0603, Y5V, 50V, 20%	Samsung	CL10F104ZBNC	4
C112	0.1uF, 0603, Y5V, 50V, 20%	Samsung	CL10F104ZBNC	4
C113	0.1uF, 0603, Y5V, 50V, 20%	Samsung	CL10F104ZBNC	4
C114	0.1uF, 0603, Y5V, 50V, 20%	Samsung	CL10F104ZBNC	4
C115	0.1uF, 0603, Y5V, 50V, 20%	Samsung	CL10F104ZBNC	4
C116	0.1uF, 0603, Y5V, 50V, 20%	Samsung	CL10F104ZBNC	4
C117	0.1uF, 0603, Y5V, 50V, 20%	Samsung	CL10F104ZBNC	4
C118	0.1uF, 0603, Y5V, 50V, 20%	Samsung	CL10F104ZBNC	4
C119	0.1uF, 0603, Y5V, 50V, 20%	Samsung	CL10F104ZBNC	4
C120	0.1uF, 0603, Y5V, 50V, 20%	Samsung	CL10F104ZBNC	4
C121	0.1uF, 0603, Y5V, 50V, 20%	Samsung	CL10F104ZBNC	4
C122	0.1uF, 0603, Y5V, 50V, 20%	Samsung	CL10F104ZBNC	4
C123	0.1uF, 0603, Y5V, 50V, 20%	Samsung	CL10F104ZBNC	4
C124	0.1uF, 0603, Y5V, 50V, 20%	Samsung	CL10F104ZBNC	4
C125	0.1uF, 0603, Y5V, 50V, 20%	Samsung	CL10F104ZBNC	4
C126	0.1uF, 0603, Y5V, 50V, 20%	Samsung	CL10F104ZBNC	4
C127	0.1uF, 0603, Y5V, 50V, 20%	Samsung	CL10F104ZBNC	4
C200	47uF, 16V, 40C, 20%	NICHICON	UZT1C470MCR1GB	4
C201	0.1uF, 0603, Y5V, 50V, 20%	Samsung	CL10F104ZBNC	4
C202	0.1uF, 0603, Y5V, 50V, 20%	Samsung	CL10F104ZBNC	4
C203	47uF, 16V, 40C, 20%	NICHICON	UZT1C470MCR1GB	4
C204	0.1uF, 0603, Y5V, 50V, 20%	Samsung	CL10F104ZBNC	4
C205	0.1uF, 0603, Y5V, 50V, 20%	Samsung	CL10F104ZBNC	4
C206	0.1uF, 0603, Y5V, 50V, 20%	Samsung	CL10F104ZBNC	4
C207	47uF, 16V, 40C, 20%	NICHICON	UZT1C470MCR1GB	4
C208	10uF, 16V, 40C, 20%	NICHICON	UZT1C100MCR1GB	4
C209	0.1uF, 0603, Y5V, 50V, 20%	Samsung	CL10F104ZBNC	4
C210	0.1uF, 0603, Y5V, 50V, 20%	Samsung	CL10F104ZBNC	4
C211	10uF, 16V, 40C, 20%	NICHICON	UZT1C100MCR1GB	4
C212	0.1uF, 0603, Y5V, 50V, 20%	Samsung	CL10F104ZBNC	4
C220	47uF, 16V, 40C, 20%	NICHICON	UZT1C470MCR1GB	4
C221	47uF, 16V, 40C, 20%	NICHICON	UZT1C470MCR1GB	4
C222	0.1uF, 0603, Y5V, 50V, 20%	Samsung	CL10F104ZBNC	4
C223	0.1uF, 0603, Y5V, 50V, 20%	Samsung	CL10F104ZBNC	4
C300	47pF, 0603, 50V, 55C, NPO, 5%	Samsung	CL10C470JBNC	4

# ELECTRICAL PART LIST

ESP-88 Chassis Motherboard PCB Assembly

Capacitors (continued)

Reference Designator	Description	Vendor	Vendor Part Number	Note
C301	47pF, 0603, 50V, 55C, NPO, 5%	Samsung	CL10C470JBNC	4
C302	47pF, 0603, 50V, 55C, NPO, 5%	Samsung	CL10C470JBNC	4
C303	47pF, 0603, 50V, 55C, NPO, 5%	Samsung	CL10C470JBNC	4
C304	47pF, 0603, 50V, 55C, NPO, 5%	Samsung	CL10C470JBNC	4
C305	47pF, 0603, 50V, 55C, NPO, 5%	Samsung	CL10C470JBNC	4
C306	47pF, 0603, 50V, 55C, NPO, 5%	Samsung	CL10C470JBNC	4
C307	47pF, 0603, 50V, 55C, NPO, 5%	Samsung	CL10C470JBNC	4
C308	47pF, 0603, 50V, 55C, NPO, 5%	Samsung	CL10C470JBNC	4
C309	47pF, 0603, 50V, 55C, NPO, 5%	Samsung	CL10C470JBNC	4
C310	47pF, 0603, 50V, 55C, NPO, 5%	Samsung	CL10C470JBNC	4
C311	47pF, 0603, 50V, 55C, NPO, 5%	Samsung	CL10C470JBNC	4
C312	47pF, 0603, 50V, 55C, NPO, 5%	Samsung	CL10C470JBNC	4
C313	47pF, 0603, 50V, 55C, NPO, 5%	Samsung	CL10C470JBNC	4
C314	47pF, 0603, 50V, 55C, NPO, 5%	Samsung	CL10C470JBNC	4
C315	47pF, 0603, 50V, 55C, NPO, 5%	Samsung	CL10C470JBNC	4
C316	47pF, 0603, 50V, 55C, NPO, 5%	Samsung	CL10C470JBNC	4
C317	47pF, 0603, 50V, 55C, NPO, 5%	Samsung	CL10C470JBNC	4
C318	47pF, 0603, 50V, 55C, NPO, 5%	Samsung	CL10C470JBNC	4
C319	47pF, 0603, 50V, 55C, NPO, 5%	Samsung	CL10C470JBNC	4
C320	47pF, 0603, 50V, 55C, NPO, 5%	Samsung	CL10C470JBNC	4
C321	47pF, 0603, 50V, 55C, NPO, 5%	Samsung	CL10C470JBNC	4
C322	47pF, 0603, 50V, 55C, NPO, 5%	Samsung	CL10C470JBNC	4
C323	47pF, 0603, 50V, 55C, NPO, 5%	Samsung	CL10C470JBNC	4
C324	47pF, 0603, 50V, 55C, NPO, 5%	Samsung	CL10C470JBNC	4
C325	47pF, 0603, 50V, 55C, NPO, 5%	Samsung	CL10C470JBNC	4
C326	47pF, 0603, 50V, 55C, NPO, 5%	Samsung	CL10C470JBNC	4
C327	47pF, 0603, 50V, 55C, NPO, 5%	Samsung	CL10C470JBNC	4
C328	47pF, 0603, 50V, 55C, NPO, 5%	Samsung	CL10C470JBNC	4
C329	47pF, 0603, 50V, 55C, NPO, 5%	Samsung	CL10C470JBNC	4
C330	47pF, 0603, 50V, 55C, NPO, 5%	Samsung	CL10C470JBNC	4
C331	47pF, 0603, 50V, 55C, NPO, 5%	Samsung	CL10C470JBNC	4
C332	47pF, 0603, 50V, 55C, NPO, 5%	Samsung	CL10C470JBNC	4
C333	47pF, 0603, 50V, 55C, NPO, 5%	Samsung	CL10C470JBNC	4
C334	47pF, 0603, 50V, 55C, NPO, 5%	Samsung	CL10C470JBNC	4
C335	47pF, 0603, 50V, 55C, NPO, 5%	Samsung	CL10C470JBNC	4
C336	47pF, 0603, 50V, 55C, NPO, 5%	Samsung	CL10C470JBNC	4
C337	47pF, 0603, 50V, 55C, NPO, 5%	Samsung	CL10C470JBNC	4
C338	47pF, 0603, 50V, 55C, NPO, 5%	Samsung	CL10C470JBNC	4
C339	47pF, 0603, 50V, 55C, NPO, 5%	Samsung	CL10C470JBNC	4
C340	47pF, 0603, 50V, 55C, NPO, 5%	Samsung	CL10C470JBNC	4
C341	47pF, 0603, 50V, 55C, NPO, 5%	Samsung	CL10C470JBNC	4
C342	47pF, 0603, 50V, 55C, NPO, 5%	Samsung	CL10C470JBNC	4
C343	47pF, 0603, 50V, 55C, NPO, 5%	Samsung	CL10C470JBNC	4
C344	47pF, 0603, 50V, 55C, NPO, 5%	Samsung	CL10C470JBNC	4
C345	47pF, 0603, 50V, 55C, NPO, 5%	Samsung	CL10C470JBNC	4
C346	47pF, 0603, 50V, 55C, NPO, 5%	Samsung	CL10C470JBNC	4
C347	47pF, 0603, 50V, 55C, NPO, 5%	Samsung	CL10C470JBNC	4

# ELECTRICAL PART LIST

ESP-88 Chassis Motherboard PCB Assembly

Capacitors (continued)

Reference Designator	Description	Vendor	Vendor Part Number	Note
C348	47pF, 0603, 50V, 55C, NPO, 5%	Samsung	CL10C470JBNC	4
C349	47pF, 0603, 50V, 55C, NPO, 5%	Samsung	CL10C470JBNC	4
C350	47pF, 0603, 50V, 55C, NPO, 5%	Samsung	CL10C470JBNC	4
C351	47pF, 0603, 50V, 55C, NPO, 5%	Samsung	CL10C470JBNC	4
C352	47pF, 0603, 50V, 55C, NPO, 5%	Samsung	CL10C470JBNC	4
C353	47pF, 0603, 50V, 55C, NPO, 5%	Samsung	CL10C470JBNC	4
C354	47pF, 0603, 50V, 55C, NPO, 5%	Samsung	CL10C470JBNC	4
C355	47pF, 0603, 50V, 55C, NPO, 5%	Samsung	CL10C470JBNC	4
C356	47pF, 0603, 50V, 55C, NPO, 5%	Samsung	CL10C470JBNC	4
C357	47pF, 0603, 50V, 55C, NPO, 5%	Samsung	CL10C470JBNC	4
C358	47pF, 0603, 50V, 55C, NPO, 5%	Samsung	CL10C470JBNC	4
C359	47pF, 0603, 50V, 55C, NPO, 5%	Samsung	CL10C470JBNC	4
C360	47pF, 0603, 50V, 55C, NPO, 5%	Samsung	CL10C470JBNC	4
C361	47pF, 0603, 50V, 55C, NPO, 5%	Samsung	CL10C470JBNC	4
C362	47pF, 0603, 50V, 55C, NPO, 5%	Samsung	CL10C470JBNC	4
C363	47pF, 0603, 50V, 55C, NPO, 5%	Samsung	CL10C470JBNC	4
C364	47pF, 0603, 50V, 55C, NPO, 5%	Samsung	CL10C470JBNC	4
C365	47pF, 0603, 50V, 55C, NPO, 5%	Samsung	CL10C470JBNC	4
C366	47pF, 0603, 50V, 55C, NPO, 5%	Samsung	CL10C470JBNC	4
C367	47pF, 0603, 50V, 55C, NPO, 5%	Samsung	CL10C470JBNC	4
C368	47pF, 0603, 50V, 55C, NPO, 5%	Samsung	CL10C470JBNC	4
C369	47pF, 0603, 50V, 55C, NPO, 5%	Samsung	CL10C470JBNC	4
C370	47pF, 0603, 50V, 55C, NPO, 5%	Samsung	CL10C470JBNC	4
C371	47pF, 0603, 50V, 55C, NPO, 5%	Samsung	CL10C470JBNC	4
C372	47pF, 0603, 50V, 55C, NPO, 5%	Samsung	CL10C470JBNC	4
C373	47pF, 0603, 50V, 55C, NPO, 5%	Samsung	CL10C470JBNC	4
C374	47pF, 0603, 50V, 55C, NPO, 5%	Samsung	CL10C470JBNC	4
C375	47pF, 0603, 50V, 55C, NPO, 5%	Samsung	CL10C470JBNC	4
C376	47pF, 0603, 50V, 55C, NPO, 5%	Samsung	CL10C470JBNC	4
C377	47pF, 0603, 50V, 55C, NPO, 5%	Samsung	CL10C470JBNC	4
C378	47pF, 0603, 50V, 55C, NPO, 5%	Samsung	CL10C470JBNC	4
C379	47pF, 0603, 50V, 55C, NPO, 5%	Samsung	CL10C470JBNC	4
C380	47pF, 0603, 50V, 55C, NPO, 5%	Samsung	CL10C470JBNC	4
C381	47pF, 0603, 50V, 55C, NPO, 5%	Samsung	CL10C470JBNC	4
C382	47pF, 0603, 50V, 55C, NPO, 5%	Samsung	CL10C470JBNC	4
C383	47pF, 0603, 50V, 55C, NPO, 5%	Samsung	CL10C470JBNC	4
C384	47pF, 0603, 50V, 55C, NPO, 5%	Samsung	CL10C470JBNC	4
C385	47pF, 0603, 50V, 55C, NPO, 5%	Samsung	CL10C470JBNC	4
C386	47pF, 0603, 50V, 55C, NPO, 5%	Samsung	CL10C470JBNC	4
C387	47pF, 0603, 50V, 55C, NPO, 5%	Samsung	CL10C470JBNC	4
C388	47pF, 0603, 50V, 55C, NPO, 5%	Samsung	CL10C470JBNC	4
C389	47pF, 0603, 50V, 55C, NPO, 5%	Samsung	CL10C470JBNC	4
C390	47pF, 0603, 50V, 55C, NPO, 5%	Samsung	CL10C470JBNC	4
C391	47pF, 0603, 50V, 55C, NPO, 5%	Samsung	CL10C470JBNC	4
C392	47pF, 0603, 50V, 55C, NPO, 5%	Samsung	CL10C470JBNC	4
C393	47pF, 0603, 50V, 55C, NPO, 5%	Samsung	CL10C470JBNC	4
C394	47pF, 0603, 50V, 55C, NPO, 5%	Samsung	CL10C470JBNC	4
C395	47pF, 0603, 50V, 55C, NPO, 5%	Samsung	CL10C470JBNC	4

# ELECTRICAL PART LIST

ESP-88 Chassis Motherboard PCB Assembly

## Diodes

Reference Designator	Description	Vendor	Vendor Part Number	Note
D200	400V, 1A, 1SR154-400, SOD-106	ROHM	1SR154-400	4
D201	400V, 1A, 1SR154-400, SOD-106	ROHM	1SR154-400	4
D202	400V, 1A, 1SR154-400, SOD-106	ROHM	1SR154-400	4
D207	400V, 1A, 1SR154-400, SOD-106	ROHM	1SR154-400	4
D208	400V, 1A, 1SR154-400, SOD-106	ROHM	1SR154-400	4

## Transistors

Reference Designator	Description	Vendor	Vendor Part Number	Note
Q100	PNP, 50V, 100mA, SOT-23	KEC	KRA102S	4
Q202	PNP, 60V, 1A, SOT-89	KEC	KTA1668Y	4
Q203	NPN, 50V, 100mA, SOT-23	KEC	KRC102S	4
Q205	NPN, 50V, 100mA, SOT-23	KEC	KRC102S	4
Q211	PNP, 50V, 100mA, SOT-23	KEC	KRA102S	4

## Integrated Circuits

Reference Designator	Description	Vendor	Vendor Part Number	Note
M100	DECODER, TSSOP-16	ONSEMI	MC74VHC138DT	4
M101	OCTAL BUS BUFFER, TSSOP-20	ONSEMI	MC74VHC541DT	4
M102	OCTAL BUS BUFFER, TSSOP-20	ONSEMI	MC74VHC541DT	4
M103	OCTAL BUS BUFFER, TSSOP-20	ONSEMI	MC74VHC541DT	4
M104	DECODER, TSSOP-16	ONSEMI	MC74VHC138DT	4
M200	REGULATOR, 3.3V, 1A, TO-252	NEC	UPC2933T	4

## Miscellaneous

Reference Designator	Description	Vendor	Vendor Part Number	Note
CN100	CONN, P1.0MM, 30 PIN, MALE	KEL Corp.	87BMN-030S	4
CN101	CONN, P1.0MM, 30 PIN, MALE	KEL Corp.	87BMN-030S	4
CN102	CONN, P1.0MM, 30 PIN, MALE	KEL Corp.	87BMN-030S	4
CN103	CONN, P1.0MM, 30 PIN, MALE	KEL Corp.	87BMN-030S	4
CN104	CONN, P1.0MM, 30 PIN, MALE	KEL Corp.	87BMN-030S	4
CN105	CONN, P1.0MM, 30 PIN, MALE	KEL Corp.	87BMN-030S	4
CN106	CONN, P1.0MM, 30 PIN, MALE	KEL Corp.	87BMN-030S	4
CN107	CONN, P1.0MM, 30 PIN, MALE	KEL Corp.	87BMN-030S	4
CN108	CONN, P1.0MM, 100 PIN, MALE	KEL Corp.	87BMN-100S	4
CN200	WIRE TO BOARD HEADER, P3.96MM, 6 POLES, 2114S-06	CompuTime	4024406-----0N19	4
CN202	WIRE TO BOARD HEADER, P2.5MM, 8 POLES, 2317SJ-08	CompuTime	4024208-----0N19	4
CN203	WIRE TO BOARD HEADER, P2.5MM, 8 POLES, 2317SJ-08	CompuTime	4024208-----0N19	4
CN205	WIRE TO BOARD HEADER, P2.5MM, 3 POLES, 2317SJ-03	CompuTime	4024203-----0N19	4



# ELECTRICAL PART LIST

ESP-88 Chassis 4x4 PCB Assembly

Resistors

Reference Designator	Description	Vendor Name	Vendor Part Number	Note
JP100	0 OHM, 0603, 1/10W, 5%	Yageo	RC0603JR-07R00	4
JP101	0 OHM, 0603, 1/10W, 5%	Yageo	RC0603JR-07R00	4
JP102	0 OHM, 0603, 1/10W, 5%	Yageo	RC0603JR-07R00	4
JP103	0 OHM, 0603, 1/10W, 5%	Yageo	RC0603JR-07R00	4
JP104	0 OHM, 0603, 1/10W, 5%	Yageo	RC0603JR-07R00	4
JP200	0 OHM, 0603, 1/10W, 5%	Yageo	RC0603JR-07R00	4
JP201	0 OHM, 0603, 1/10W, 5%	Yageo	RC0603JR-07R00	4
JP202	0 OHM, 0603, 1/10W, 5%	Yageo	RC0603JR-07R00	4
JP203	0 OHM, 0603, 1/10W, 5%	Yageo	RC0603JR-07R00	4
JP204	0 OHM, 0603, 1/10W, 5%	Yageo	RC0603JR-07R00	4
JP300	0 OHM, 0603, 1/10W, 5%	Yageo	RC0603JR-07R00	4
JP301	0 OHM, 0603, 1/10W, 5%	Yageo	RC0603JR-07R00	4
JP400	0 OHM, 0603, 1/10W, 5%	Yageo	RC0603JR-07R00	4
JP401	0 OHM, 0603, 1/10W, 5%	Yageo	RC0603JR-07R00	4
JP500	0 OHM, 0603, 1/10W, 5%	Yageo	RC0603JR-07R00	4
JP501	0 OHM, 0603, 1/10W, 5%	Yageo	RC0603JR-07R00	4
JP550	0 OHM, 0603, 1/10W, 5%	Yageo	RC0603JR-07R00	4
JP551	0 OHM, 0603, 1/10W, 5%	Yageo	RC0603JR-07R00	4
R100	100K, 0603, 1/10W, 1%	Yageo	RC0603FR-07100K	4
R101	100 OHM, 0603, 1/10W, 1%	Yageo	RC0603FR-07100R	4
R102	100 OHM, 0603, 1/10W, 1%	Yageo	RC0603FR-07100R	4
R103	100K, 0603, 1/10W, 1%	Yageo	RC0603FR-07100K	4
R110	1.3K, 0603, 1/10W, 1%	Yageo	RC0603FR-071K3	4
R112	5.1K, 0603, 1/10W, 1%	Yageo	RC0603FR-075K1	4
R115	82 OHM, 0603, 1/10W, 1%	Yageo	RC0603FR-0782R	4
R117	68 OHM, 0603, 1/10W, 1%	Yageo	RC0603FR-0768R	4
R120	1.3K, 0603, 1/10W, 1%	Yageo	RC0603FR-071K3	4
R122	5.1K, 0603, 1/10W, 1%	Yageo	RC0603FR-075K1	4
R125	82 OHM, 0603, 1/10W, 1%	Yageo	RC0603FR-0782R	4
R127	68 OHM, 0603, 1/10W, 1%	Yageo	RC0603FR-0768R	4
R131	680 OHM, 0603, 1/10W, 1%	Yageo	RC0603FR-07680R	4
R132	680 OHM, 0603, 1/10W, 1%	Yageo	RC0603FR-07680R	4
R133	680 OHM, 0603, 1/10W, 1%	Yageo	RC0603FR-07680R	4
R134	680 OHM, 0603, 1/10W, 1%	Yageo	RC0603FR-07680R	4
R135	680 OHM, 0603, 1/10W, 1%	Yageo	RC0603FR-07680R	4
R136	680 OHM, 0603, 1/10W, 1%	Yageo	RC0603FR-07680R	4
R137	680 OHM, 0603, 1/10W, 1%	Yageo	RC0603FR-07680R	4
R138	680 OHM, 0603, 1/10W, 1%	Yageo	RC0603FR-07680R	4
R141	39K, 0603, 1/10W, 1%	Yageo	RC0603FR-0739K	4
R142	39K, 0603, 1/10W, 1%	Yageo	RC0603FR-0739K	4
R143	39K, 0603, 1/10W, 1%	Yageo	RC0603FR-0739K	4
R144	10K, 0603, 1/10W, 1%	Yageo	RC0603FR-0710K	4
R145	10K, 0603, 1/10W, 1%	Yageo	RC0603FR-0710K	4
R146	6.8K, 0603, 1/10W, 1%	Yageo	RC0603FR-076K8	4
R147	12K, 0603, 1/10W, 1%	Yageo	RC0603FR-0712K	4
R148	6.8K, 0603, 1/10W, 1%	Yageo	RC0603FR-076K8	4
R149	12K, 0603, 1/10W, 1%	Yageo	RC0603FR-0712K	4



# ELECTRICAL PART LIST

ESP-88 Chassis 4x4 PCB Assembly

Resistors (continued)

Reference Designator	Description	Vendor Name	Vendor Part Number	Note
R150	12K, 0603, 1/10W, 1%	Yageo	RC0603FR-0712K	4
R151	6.8K, 0603, 1/10W, 1%	Yageo	RC0603FR-076K8	4
R152	6.8K, 0603, 1/10W, 1%	Yageo	RC0603FR-076K8	4
R153	12K, 0603, 1/10W, 1%	Yageo	RC0603FR-0712K	4
R156	12K, 0603, 1/10W, 1%	Yageo	RC0603FR-0712K	4
R157	6.8K, 0603, 1/10W, 1%	Yageo	RC0603FR-076K8	4
R158	6.8K, 0603, 1/10W, 1%	Yageo	RC0603FR-076K8	4
R159	12K, 0603, 1/10W, 1%	Yageo	RC0603FR-0712K	4
R160	12K, 0603, 1/10W, 1%	Yageo	RC0603FR-0712K	4
R161	6.8K, 0603, 1/10W, 1%	Yageo	RC0603FR-076K8	4
R162	12K, 0603, 1/10W, 1%	Yageo	RC0603FR-0712K	4
R163	6.8K, 0603, 1/10W, 1%	Yageo	RC0603FR-076K8	4
R164	10K, 0603, 1/10W, 1%	Yageo	RC0603FR-0710K	4
R165	10K, 0603, 1/10W, 1%	Yageo	RC0603FR-0710K	4
R166	39K, 0603, 1/10W, 1%	Yageo	RC0603FR-0739K	4
R167	39K, 0603, 1/10W, 1%	Yageo	RC0603FR-0739K	4
R168	39K, 0603, 1/10W, 1%	Yageo	RC0603FR-0739K	4
R169	4.7K, 0603, 1/10W, 1%	Yageo	RC0603FR-074K7	4
R170	1.8K, 0603, 1/10W, 1%	Yageo	RC0603FR-071K8	4
R171	1.2K, 0603, 1/10W, 1%	Yageo	RC0603FR-071K2	4
R172	4.7K, 0603, 1/10W, 1%	Yageo	RC0603FR-074K7	4
R173	4.7K, 0603, 1/10W, 1%	Yageo	RC0603FR-074K7	4
R174	1.8K, 0603, 1/10W, 1%	Yageo	RC0603FR-071K8	4
R175	1.2K, 0603, 1/10W, 1%	Yageo	RC0603FR-071K2	4
R176	4.7K, 0603, 1/10W, 1%	Yageo	RC0603FR-074K7	4
R200	100K, 0603, 1/10W, 1%	Yageo	RC0603FR-07100K	4
R201	100 OHM, 0603, 1/10W, 1%	Yageo	RC0603FR-07100R	4
R202	100 OHM, 0603, 1/10W, 1%	Yageo	RC0603FR-07100R	4
R203	100K, 0603, 1/10W, 1%	Yageo	RC0603FR-07100K	4
R210	1.3K, 0603, 1/10W, 1%	Yageo	RC0603FR-071K3	4
R212	5.1K, 0603, 1/10W, 1%	Yageo	RC0603FR-075K1	4
R215	82 OHM, 0603, 1/10W, 1%	Yageo	RC0603FR-0782R	4
R217	68 OHM, 0603, 1/10W, 1%	Yageo	RC0603FR-0768R	4
R220	1.3K, 0603, 1/10W, 1%	Yageo	RC0603FR-071K3	4
R222	5.1K, 0603, 1/10W, 1%	Yageo	RC0603FR-075K1	4
R225	82 OHM, 0603, 1/10W, 1%	Yageo	RC0603FR-0782R	4
R227	68 OHM, 0603, 1/10W, 1%	Yageo	RC0603FR-0768R	4
R231	680 OHM, 0603, 1/10W, 1%	Yageo	RC0603FR-07680R	4
R232	680 OHM, 0603, 1/10W, 1%	Yageo	RC0603FR-07680R	4
R233	680 OHM, 0603, 1/10W, 1%	Yageo	RC0603FR-07680R	4
R234	680 OHM, 0603, 1/10W, 1%	Yageo	RC0603FR-07680R	4
R235	680 OHM, 0603, 1/10W, 1%	Yageo	RC0603FR-07680R	4
R236	680 OHM, 0603, 1/10W, 1%	Yageo	RC0603FR-07680R	4
R237	680 OHM, 0603, 1/10W, 1%	Yageo	RC0603FR-07680R	4
R238	680 OHM, 0603, 1/10W, 1%	Yageo	RC0603FR-07680R	4
R241	39K, 0603, 1/10W, 1%	Yageo	RC0603FR-0739K	4
R242	39K, 0603, 1/10W, 1%	Yageo	RC0603FR-0739K	4

# ELECTRICAL PART LIST

ESP-88 Chassis 4x4 PCB Assembly

Resistors (continued)

Reference Designator	Description	Vendor Name	Vendor Part Number	Note
R243	39K, 0603, 1/10W, 1%	Yageo	RC0603FR-0739K	4
R244	10K, 0603, 1/10W, 1%	Yageo	RC0603FR-0710K	4
R245	10K, 0603, 1/10W, 1%	Yageo	RC0603FR-0710K	4
R246	6.8K, 0603, 1/10W, 1%	Yageo	RC0603FR-076K8	4
R247	12K, 0603, 1/10W, 1%	Yageo	RC0603FR-0712K	4
R248	6.8K, 0603, 1/10W, 1%	Yageo	RC0603FR-076K8	4
R249	12K, 0603, 1/10W, 1%	Yageo	RC0603FR-0712K	4
R250	12K, 0603, 1/10W, 1%	Yageo	RC0603FR-0712K	4
R251	6.8K, 0603, 1/10W, 1%	Yageo	RC0603FR-076K8	4
R252	6.8K, 0603, 1/10W, 1%	Yageo	RC0603FR-076K8	4
R253	12K, 0603, 1/10W, 1%	Yageo	RC0603FR-0712K	4
R256	12K, 0603, 1/10W, 1%	Yageo	RC0603FR-0712K	4
R257	6.8K, 0603, 1/10W, 1%	Yageo	RC0603FR-076K8	4
R258	6.8K, 0603, 1/10W, 1%	Yageo	RC0603FR-076K8	4
R259	12K, 0603, 1/10W, 1%	Yageo	RC0603FR-0712K	4
R260	12K, 0603, 1/10W, 1%	Yageo	RC0603FR-0712K	4
R261	6.8K, 0603, 1/10W, 1%	Yageo	RC0603FR-076K8	4
R262	12K, 0603, 1/10W, 1%	Yageo	RC0603FR-0712K	4
R263	6.8K, 0603, 1/10W, 1%	Yageo	RC0603FR-076K8	4
R264	10K, 0603, 1/10W, 1%	Yageo	RC0603FR-0710K	4
R265	10K, 0603, 1/10W, 1%	Yageo	RC0603FR-0710K	4
R266	39K, 0603, 1/10W, 1%	Yageo	RC0603FR-0739K	4
R267	39K, 0603, 1/10W, 1%	Yageo	RC0603FR-0739K	4
R268	39K, 0603, 1/10W, 1%	Yageo	RC0603FR-0739K	4
R269	4.7K, 0603, 1/10W, 1%	Yageo	RC0603FR-074K7	4
R270	1.8K, 0603, 1/10W, 1%	Yageo	RC0603FR-071K8	4
R271	1.2K, 0603, 1/10W, 1%	Yageo	RC0603FR-071K2	4
R272	4.7K, 0603, 1/10W, 1%	Yageo	RC0603FR-074K7	4
R273	4.7K, 0603, 1/10W, 1%	Yageo	RC0603FR-074K7	4
R274	1.8K, 0603, 1/10W, 1%	Yageo	RC0603FR-071K8	4
R275	1.2K, 0603, 1/10W, 1%	Yageo	RC0603FR-071K2	4
R276	4.7K, 0603, 1/10W, 1%	Yageo	RC0603FR-074K7	4
R300	10K, 0603, 1/10W, 1%	Yageo	RC0603FR-0710K	4
R301	47K, 0603, 1/10W, 1%	Yageo	RC0603FR-0747K	4
R302	10K, 0603, 1/10W, 1%	Yageo	RC0603FR-0710K	4
R303	10K, 0603, 1/10W, 1%	Yageo	RC0603FR-0710K	4
R304	10K, 0603, 1/10W, 1%	Yageo	RC0603FR-0710K	4
R305	47K, 0603, 1/10W, 1%	Yageo	RC0603FR-0747K	4
R307	16K, 0603, 1/10W, 1%	Yageo	RC0603FR-0716K	4
R308	10K, 0603, 1/10W, 1%	Yageo	RC0603FR-0710K	4
R309	4.7K, 0603, 1/10W, 1%	Yageo	RC0603FR-074K7	4
R310	18 OHM, 0603, 1/10W, 1%	Yageo	RC0603FR-0718R	4
R311	18 OHM, 0603, 1/10W, 1%	Yageo	RC0603FR-0718R	4
R312	18 OHM, 0603, 1/10W, 1%	Yageo	RC0603FR-0718R	4
R313	18 OHM, 0603, 1/10W, 1%	Yageo	RC0603FR-0718R	4
R314	10K, 0603, 1/10W, 1%	Yageo	RC0603FR-0710K	4
R315	10K, 0603, 1/10W, 1%	Yageo	RC0603FR-0710K	4

# ELECTRICAL PART LIST

ESP-88 Chassis 4x4 PCB Assembly

Resistors (continued)

Reference Designator	Description	Vendor Name	Vendor Part Number	Note
R316	10K, 0603, 1/10W, 1%	Yageo	RC0603FR-0710K	4
R317	10K, 0603, 1/10W, 1%	Yageo	RC0603FR-0710K	4
R318	10K, 0603, 1/10W, 1%	Yageo	RC0603FR-0710K	4
R319	10K, 0603, 1/10W, 1%	Yageo	RC0603FR-0710K	4
R320	10K, 0603, 1/10W, 1%	Yageo	RC0603FR-0710K	4
R321	10K, 0603, 1/10W, 1%	Yageo	RC0603FR-0710K	4
R322	10K, 0603, 1/10W, 1%	Yageo	RC0603FR-0710K	4
R323	10K, 0603, 1/10W, 1%	Yageo	RC0603FR-0710K	4
R324	100 OHM, 0603, 1/10W, 1%	Yageo	RC0603FR-07100R	4
R325	100 OHM, 0603, 1/10W, 1%	Yageo	RC0603FR-07100R	4
R326	8.2K, 0603, 1/10W, 1%	Yageo	RC0603FR-078K2	4
R327	6.8K, 0603, 1/10W, 1%	Yageo	RC0603FR-076K8	4
R328	5.6K, 0603, 1/10W, 1%	Yageo	RC0603FR-075K6	4
R329	3.3K, 0603, 1/10W, 1%	Yageo	RC0603FR-073K3	4
R330	8.2K, 0603, 1/10W, 1%	Yageo	RC0603FR-078K2	4
R331	1.5K, 0603, 1/10W, 1%	Yageo	RC0603FR-071K5	4
R332	2.2K, 0603, 1/10W, 1%	Yageo	RC0603FR-072K2	4
R333	12K, 0603, 1/10W, 1%	Yageo	RC0603FR-0712K	4
R334	2.7K, 0603, 1/10W, 1%	Yageo	RC0603FR-072K7	4
R336	4.7K, 0603, 1/10W, 1%	Yageo	RC0603FR-074K7	4
R337	10K, 0603, 1/10W, 1%	Yageo	RC0603FR-0710K	4
R338	16K, 0603, 1/10W, 1%	Yageo	RC0603FR-0716K	4
R339	18 OHM, 0603, 1/10W, 1%	Yageo	RC0603FR-0718R	4
R340	18 OHM, 0603, 1/10W, 1%	Yageo	RC0603FR-0718R	4
R341	18 OHM, 0603, 1/10W, 1%	Yageo	RC0603FR-0718R	4
R342	18 OHM, 0603, 1/10W, 1%	Yageo	RC0603FR-0718R	4
R343	10K, 0603, 1/10W, 1%	Yageo	RC0603FR-0710K	4
R344	10K, 0603, 1/10W, 1%	Yageo	RC0603FR-0710K	4
R345	10K, 0603, 1/10W, 1%	Yageo	RC0603FR-0710K	4
R346	10K, 0603, 1/10W, 1%	Yageo	RC0603FR-0710K	4
R347	10K, 0603, 1/10W, 1%	Yageo	RC0603FR-0710K	4
R348	10K, 0603, 1/10W, 1%	Yageo	RC0603FR-0710K	4
R349	10K, 0603, 1/10W, 1%	Yageo	RC0603FR-0710K	4
R350	10K, 0603, 1/10W, 1%	Yageo	RC0603FR-0710K	4
R351	10K, 0603, 1/10W, 1%	Yageo	RC0603FR-0710K	4
R352	10K, 0603, 1/10W, 1%	Yageo	RC0603FR-0710K	4
R353	10K, 0603, 1/10W, 1%	Yageo	RC0603FR-0710K	4
R354	10K, 0603, 1/10W, 1%	Yageo	RC0603FR-0710K	4
R355	100 OHM, 0603, 1/10W, 1%	Yageo	RC0603FR-07100R	4
R356	100 OHM, 0603, 1/10W, 1%	Yageo	RC0603FR-07100R	4
R357	8.2K, 0603, 1/10W, 1%	Yageo	RC0603FR-078K2	4
R358	6.8K, 0603, 1/10W, 1%	Yageo	RC0603FR-076K8	4
R359	5.6K, 0603, 1/10W, 1%	Yageo	RC0603FR-075K6	4
R360	3.3K, 0603, 1/10W, 1%	Yageo	RC0603FR-073K3	4
R361	8.2K, 0603, 1/10W, 1%	Yageo	RC0603FR-078K2	4
R362	1.5K, 0603, 1/10W, 1%	Yageo	RC0603FR-071K5	4
R363	2.2K, 0603, 1/10W, 1%	Yageo	RC0603FR-072K2	4

# ELECTRICAL PART LIST

ESP-88 Chassis 4x4 PCB Assembly

Resistors (continued)

Reference Designator	Description	Vendor Name	Vendor Part Number	Note
R364	12K, 0603, 1/10W, 1%	Yageo	RC0603FR-0712K	4
R365	2.7K, 0603, 1/10W, 1%	Yageo	RC0603FR-072K7	4
R366	10K, 0603, 1/10W, 1%	Yageo	RC0603FR-0710K	4
R367	10K, 0603, 1/10W, 1%	Yageo	RC0603FR-0710K	4
R368	0 OHM, 0603, 1/10W, 5%	Yageo	RC0603JR-07R00	4
R369	0 OHM, 0603, 1/10W, 5%	Yageo	RC0603JR-07R00	4
R370	0 OHM, 0603, 1/10W, 5%	Yageo	RC0603JR-07R00	4
R371	0 OHM, 0603, 1/10W, 5%	Yageo	RC0603JR-07R00	4
R400	10K, 0603, 1/10W, 1%	Yageo	RC0603FR-0710K	4
R401	47K, 0603, 1/10W, 1%	Yageo	RC0603FR-0747K	4
R402	10K, 0603, 1/10W, 1%	Yageo	RC0603FR-0710K	4
R403	10K, 0603, 1/10W, 1%	Yageo	RC0603FR-0710K	4
R404	10K, 0603, 1/10W, 1%	Yageo	RC0603FR-0710K	4
R405	47K, 0603, 1/10W, 1%	Yageo	RC0603FR-0747K	4
R407	16K, 0603, 1/10W, 1%	Yageo	RC0603FR-0716K	4
R408	10K, 0603, 1/10W, 1%	Yageo	RC0603FR-0710K	4
R409	4.7K, 0603, 1/10W, 1%	Yageo	RC0603FR-074K7	4
R410	18 OHM, 0603, 1/10W, 1%	Yageo	RC0603FR-0718R	4
R411	18 OHM, 0603, 1/10W, 1%	Yageo	RC0603FR-0718R	4
R412	18 OHM, 0603, 1/10W, 1%	Yageo	RC0603FR-0718R	4
R413	18 OHM, 0603, 1/10W, 1%	Yageo	RC0603FR-0718R	4
R414	10K, 0603, 1/10W, 1%	Yageo	RC0603FR-0710K	4
R415	10K, 0603, 1/10W, 1%	Yageo	RC0603FR-0710K	4
R416	10K, 0603, 1/10W, 1%	Yageo	RC0603FR-0710K	4
R417	10K, 0603, 1/10W, 1%	Yageo	RC0603FR-0710K	4
R418	10K, 0603, 1/10W, 1%	Yageo	RC0603FR-0710K	4
R419	10K, 0603, 1/10W, 1%	Yageo	RC0603FR-0710K	4
R420	10K, 0603, 1/10W, 1%	Yageo	RC0603FR-0710K	4
R421	10K, 0603, 1/10W, 1%	Yageo	RC0603FR-0710K	4
R422	10K, 0603, 1/10W, 1%	Yageo	RC0603FR-0710K	4
R423	10K, 0603, 1/10W, 1%	Yageo	RC0603FR-0710K	4
R424	100 OHM, 0603, 1/10W, 1%	Yageo	RC0603FR-07100R	4
R425	100 OHM, 0603, 1/10W, 1%	Yageo	RC0603FR-07100R	4
R426	8.2K, 0603, 1/10W, 1%	Yageo	RC0603FR-078K2	4
R427	6.8K, 0603, 1/10W, 1%	Yageo	RC0603FR-076K8	4
R428	5.6K, 0603, 1/10W, 1%	Yageo	RC0603FR-075K6	4
R429	3.3K, 0603, 1/10W, 1%	Yageo	RC0603FR-073K3	4
R430	8.2K, 0603, 1/10W, 1%	Yageo	RC0603FR-078K2	4
R431	1.5K, 0603, 1/10W, 1%	Yageo	RC0603FR-071K5	4
R432	2.2K, 0603, 1/10W, 1%	Yageo	RC0603FR-072K2	4
R433	12K, 0603, 1/10W, 1%	Yageo	RC0603FR-0712K	4
R434	2.7K, 0603, 1/10W, 1%	Yageo	RC0603FR-072K7	4
R436	16K, 0603, 1/10W, 1%	Yageo	RC0603FR-0716K	4
R437	10K, 0603, 1/10W, 1%	Yageo	RC0603FR-0710K	4
R438	4.7K, 0603, 1/10W, 1%	Yageo	RC0603FR-074K7	4
R439	18 OHM, 0603, 1/10W, 1%	Yageo	RC0603FR-0718R	4
R440	18 OHM, 0603, 1/10W, 1%	Yageo	RC0603FR-0718R	4



# ELECTRICAL PART LIST

ESP-88 Chassis 4x4 PCB Assembly

Resistors (continued)

Reference Designator	Description	Vendor Name	Vendor Part Number	Note
R441	18 OHM, 0603, 1/10W, 1%	Yageo	RC0603FR-0718R	4
R442	18 OHM, 0603, 1/10W, 1%	Yageo	RC0603FR-0718R	4
R443	10K, 0603, 1/10W, 1%	Yageo	RC0603FR-0710K	4
R444	10K, 0603, 1/10W, 1%	Yageo	RC0603FR-0710K	4
R445	10K, 0603, 1/10W, 1%	Yageo	RC0603FR-0710K	4
R446	10K, 0603, 1/10W, 1%	Yageo	RC0603FR-0710K	4
R447	10K, 0603, 1/10W, 1%	Yageo	RC0603FR-0710K	4
R448	10K, 0603, 1/10W, 1%	Yageo	RC0603FR-0710K	4
R449	10K, 0603, 1/10W, 1%	Yageo	RC0603FR-0710K	4
R450	10K, 0603, 1/10W, 1%	Yageo	RC0603FR-0710K	4
R451	10K, 0603, 1/10W, 1%	Yageo	RC0603FR-0710K	4
R452	10K, 0603, 1/10W, 1%	Yageo	RC0603FR-0710K	4
R453	10K, 0603, 1/10W, 1%	Yageo	RC0603FR-0710K	4
R454	10K, 0603, 1/10W, 1%	Yageo	RC0603FR-0710K	4
R455	100 OHM, 0603, 1/10W, 1%	Yageo	RC0603FR-07100R	4
R456	100 OHM, 0603, 1/10W, 1%	Yageo	RC0603FR-07100R	4
R457	8.2K, 0603, 1/10W, 1%	Yageo	RC0603FR-078K2	4
R458	6.8K, 0603, 1/10W, 1%	Yageo	RC0603FR-076K8	4
R459	5.6K, 0603, 1/10W, 1%	Yageo	RC0603FR-075K6	4
R460	3.3K, 0603, 1/10W, 1%	Yageo	RC0603FR-073K3	4
R461	8.2K, 0603, 1/10W, 1%	Yageo	RC0603FR-078K2	4
R462	1.5K, 0603, 1/10W, 1%	Yageo	RC0603FR-071K5	4
R463	2.2K, 0603, 1/10W, 1%	Yageo	RC0603FR-072K2	4
R464	12K, 0603, 1/10W, 1%	Yageo	RC0603FR-0712K	4
R465	2.7K, 0603, 1/10W, 1%	Yageo	RC0603FR-072K7	4
R466	10K, 0603, 1/10W, 1%	Yageo	RC0603FR-0710K	4
R467	10K, 0603, 1/10W, 1%	Yageo	RC0603FR-0710K	4
R468	0 OHM, 0603, 1/10W, 5%	Yageo	RC0603JR-07R00	4
R469	0 OHM, 0603, 1/10W, 5%	Yageo	RC0603JR-07R00	4
R470	0 OHM, 0603, 1/10W, 5%	Yageo	RC0603JR-07R00	4
R471	0 OHM, 0603, 1/10W, 5%	Yageo	RC0603JR-07R00	4
R504	10K, 0603, 1/10W, 1%	Yageo	RC0603FR-0710K	4
R505	10K, 0603, 1/10W, 1%	Yageo	RC0603FR-0710K	4
R506	470 OHM, 0603, 1/10W, 1%	Yageo	RC0603FR-07470R	4
R507	470 OHM, 0603, 1/10W, 1%	Yageo	RC0603FR-07470R	4
R508	470 OHM, 0603, 1/10W, 1%	Yageo	RC0603FR-07470R	4
R509	470 OHM, 0603, 1/10W, 1%	Yageo	RC0603FR-07470R	4
R510	3.3K, 0603, 1/10W, 1%	Yageo	RC0603FR-073K3	4
R511	3.3K, 0603, 1/10W, 1%	Yageo	RC0603FR-073K3	4
R512	5.1 OHM, 0603, 1/10W, 1%	Yageo	RC0603FR-075R1	4
R515	5.1 OHM, 0603, 1/10W, 1%	Yageo	RC0603FR-075R1	4
R516	3.3K, 0603, 1/10W, 1%	Yageo	RC0603FR-073K3	4
R517	3.3K, 0603, 1/10W, 1%	Yageo	RC0603FR-073K3	4
R518	470 OHM, 0603, 1/10W, 1%	Yageo	RC0603FR-07470R	4
R519	470 OHM, 0603, 1/10W, 1%	Yageo	RC0603FR-07470R	4
R520	470 OHM, 0603, 1/10W, 1%	Yageo	RC0603FR-07470R	4
R521	470 OHM, 0603, 1/10W, 1%	Yageo	RC0603FR-07470R	4

# ELECTRICAL PART LIST

ESP-88 Chassis 4x4 PCB Assembly

Resistors (continued)

Reference Designator	Description	Vendor Name	Vendor Part Number	Note
R522	33 OHM, 0603, 1/10W, 1%	Yageo	RC0603FR-0733R	4
R523	330 OHM, 0603, 1/10W, 1%	Yageo	RC0603FR-07330R	4
R524	330 OHM, 0603, 1/10W, 1%	Yageo	RC0603FR-07330R	4
R525	33 OHM, 0603, 1/10W, 1%	Yageo	RC0603FR-0733R	4
R526	330 OHM, 0603, 1/10W, 1%	Yageo	RC0603FR-07330R	4
R527	330 OHM, 0603, 1/10W, 1%	Yageo	RC0603FR-07330R	4
R552	5.1 OHM, 0603, 1/10W, 1%	Yageo	RC0603FR-075R1	4
R555	5.1 OHM, 0603, 1/10W, 1%	Yageo	RC0603FR-075R1	4
R556	33 OHM, 0603, 1/10W, 1%	Yageo	RC0603FR-0733R	4
R557	180 OHM, 0603, 1/10W, 5%	Yageo	RC0603JR-07180R	4
R558	180 OHM, 0603, 1/10W, 5%	Yageo	RC0603JR-07180R	4
R559	180 OHM, 0603, 1/10W, 5%	Yageo	RC0603JR-07180R	4
R560	33 OHM, 0603, 1/10W, 1%	Yageo	RC0603FR-0733R	4
R561	180 OHM, 0603, 1/10W, 5%	Yageo	RC0603JR-07180R	4
R562	180 OHM, 0603, 1/10W, 5%	Yageo	RC0603JR-07180R	4
R563	180 OHM, 0603, 1/10W, 5%	Yageo	RC0603JR-07180R	4
R700	0 OHM, 0603, 1/10W, 5%	Yageo	RC0603JR-07R00	4
R702	10K, 0603, 1/10W, 1%	Yageo	RC0603FR-0710K	4
R703	10K, 0603, 1/10W, 1%	Yageo	RC0603FR-0710K	4
R706	330 OHM, 0603, 1/10W, 1%	Yageo	RC0603FR-07330R	4
R707	330 OHM, 0603, 1/10W, 1%	Yageo	RC0603FR-07330R	4
R708	330 OHM, 0603, 1/10W, 1%	Yageo	RC0603FR-07330R	4
R709	330 OHM, 0603, 1/10W, 1%	Yageo	RC0603FR-07330R	4
R710	330 OHM, 0603, 1/10W, 1%	Yageo	RC0603FR-07330R	4
R711	330 OHM, 0603, 1/10W, 1%	Yageo	RC0603FR-07330R	4
R712	330 OHM, 0603, 1/10W, 1%	Yageo	RC0603FR-07330R	4
R713	330 OHM, 0603, 1/10W, 1%	Yageo	RC0603FR-07330R	4
R714	10K, 0603, 1/10W, 1%	Yageo	RC0603FR-0710K	4
R716	10K, 0603, 1/10W, 1%	Yageo	RC0603FR-0710K	4
R719	330 OHM, 0603, 1/10W, 1%	Yageo	RC0603FR-07330R	4
R720	330 OHM, 0603, 1/10W, 1%	Yageo	RC0603FR-07330R	4
R721	330 OHM, 0603, 1/10W, 1%	Yageo	RC0603FR-07330R	4
R722	330 OHM, 0603, 1/10W, 1%	Yageo	RC0603FR-07330R	4
R723	330 OHM, 0603, 1/10W, 1%	Yageo	RC0603FR-07330R	4
R724	330 OHM, 0603, 1/10W, 1%	Yageo	RC0603FR-07330R	4
R725	330 OHM, 0603, 1/10W, 1%	Yageo	RC0603FR-07330R	4
R726	330 OHM, 0603, 1/10W, 1%	Yageo	RC0603FR-07330R	4
R727	0 OHM, 0603, 1/10W, 5%	Yageo	RC0603JR-07R00	4
R728	0 OHM, 0603, 1/10W, 5%	Yageo	RC0603JR-07R00	4
R730	10K, 0603, 1/10W, 1%	Yageo	RC0603FR-0710K	4
R731	10K, 0603, 1/10W, 1%	Yageo	RC0603FR-0710K	4
R732	10K, 0603, 1/10W, 1%	Yageo	RC0603FR-0710K	4
R733	10K, 0603, 1/10W, 1%	Yageo	RC0603FR-0710K	4
R734	4.7K, 0603, 1/10W, 1%	Yageo	RC0603FR-074K7	4
R735	0 OHM, 0603, 1/10W, 5%	Yageo	RC0603JR-07R00	4
R736	33 OHM, 0603, 1/10W, 1%	Yageo	RC0603FR-0733R	4
R737	33 OHM, 0603, 1/10W, 1%	Yageo	RC0603FR-0733R	4

# ELECTRICAL PART LIST

ESP-88 Chassis 4x4 PCB Assembly

Resistors (continued)

Reference Designator	Description	Vendor Name	Vendor Part Number	Note
R738	0 OHM, 0603, 1/10W, 5%	Yageo	RC0603JR-07R00	4
R740	0 OHM, 0603, 1/10W, 5%	Yageo	RC0603JR-07R00	4
R741	330 OHM, 0603, 1/10W, 1%	Yageo	RC0603FR-07330R	4
R742	330 OHM, 0603, 1/10W, 1%	Yageo	RC0603FR-07330R	4

Resistor Arrays

Reference Designator	Description	Vendor Name	Vendor Part Number	Note
RA550	10K, 10 PIN, 8R, 5%	Yageo	YC158TJR-0710K	4
RA700	33 OHM, 8 PIN, 1/16W, 5%	Yageo	YC164-JR-0733R	4
RA701	33 OHM, 8 PIN, 1/16W, 5%	Yageo	YC164-JR-0733R	4
RA702	33 OHM, 8 PIN, 1/16W, 5%	Yageo	YC164-JR-0733R	4
RA703	33 OHM, 8 PIN, 1/16W, 5%	Yageo	YC164-JR-0733R	4
RA704	33 OHM, 8 PIN, 1/16W, 5%	Yageo	YC164-JR-0733R	4
RA705	33 OHM, 8 PIN, 1/16W, 5%	Yageo	YC164-JR-0733R	4
RA706	10K, 10 PIN, 8R, 5%	Yageo	YC158TJR-0710K	4

Capacitors

Reference Designator	Description	Vendor Name	Vendor Part Number	Note
C100	0.1uF, 0603, Y5V, 50V, 20%	Samsung	CL10F104ZBNC	4
C101	10uF, ELEC, 16V, 40C, 20%	NICHICON	UZZ1C100MCR1GB	4
C102	0.1uF, 0603, Y5V, 50V, 20%	Samsung	CL10F104ZBNC	4
C103	0.1uF, 0603, Y5V, 50V, 20%	Samsung	CL10F104ZBNC	4
C104	10uF, ELEC, 16V, 40C, 20%	NICHICON	UZZ1C100MCR1GB	4
C105	0.1uF, 0603, Y5V, 50V, 20%	Samsung	CL10F104ZBNC	4
C108	0.1uF, 0603, Y5V, 50V, 20%	Samsung	CL10F104ZBNC	4
C109	0.1uF, 0603, Y5V, 50V, 20%	Samsung	CL10F104ZBNC	4
C110	0.1uF, 0603, Y5V, 50V, 20%	Samsung	CL10F104ZBNC	4
C111	0.1uF, 0603, Y5V, 50V, 20%	Samsung	CL10F104ZBNC	4
C112	0.1uF, 0603, Y5V, 50V, 20%	Samsung	CL10F104ZBNC	4
C113	0.1uF, 0603, Y5V, 50V, 20%	Samsung	CL10F104ZBNC	4
C114	0.1uF, 0603, Y5V, 50V, 20%	Samsung	CL10F104ZBNC	4
C115	0.1uF, 0603, Y5V, 50V, 20%	Samsung	CL10F104ZBNC	4
C116	0.1uF, 0603, Y5V, 50V, 20%	Samsung	CL10F104ZBNC	4
C117	0.1uF, 0603, Y5V, 50V, 20%	Samsung	CL10F104ZBNC	4
C118	47uF, ELEC, 16V, 40C, 20%	NICHICON	UZZ1C470MCR1GB	4
C119	47uF, ELEC, 16V, 40C, 20%	NICHICON	UZZ1C470MCR1GB	4
C120	47uF, ELEC, 16V, 40C, 20%	NICHICON	UZZ1C470MCR1GB	4
C121	47uF, ELEC, 16V, 40C, 20%	NICHICON	UZZ1C470MCR1GB	4
C122	10uF, ELEC, 16V, 40C, 20%	NICHICON	UZZ1C100MCR1GB	4
C123	10uF, ELEC, 16V, 40C, 20%	NICHICON	UZZ1C100MCR1GB	4
C124	10uF, ELEC, 16V, 40C, 20%	NICHICON	UZZ1C100MCR1GB	4
C125	10uF, ELEC, 16V, 40C, 20%	NICHICON	UZZ1C100MCR1GB	4
C126	10uF, BI-POLAR, 16V, 40C, 20%	ELNA	RVB16V100M-R	4
C127	100pF, 0603, NPO, 50V, 5%	Samsung	CL10C101JBNC	4
C128	100pF, 0603, NPO, 50V, 5%	Samsung	CL10C101JBNC	4



# ELECTRICAL PART LIST

ESP-88 Chassis 4x4 PCB Assembly

Capacitors (continued)

Reference Designator	Description	Vendor Name	Vendor Part Number	Note
C129	100pF, 0603, NPO, 50V, 5%	Samsung	CL10C101JBNC	4
C130	10uF, BI-POLAR, 16V, 40C, 20%	ELNA	RVB16V100M-R	4
C131	47pF, 0603, NPO, 50V, 5%	Samsung	CL10C470JBNC	4
C132	47pF, 0603, NPO, 50V, 5%	Samsung	CL10C470JBNC	4
C133	47pF, 0603, NPO, 50V, 5%	Samsung	CL10C470JBNC	4
C134	47pF, 0603, NPO, 50V, 5%	Samsung	CL10C470JBNC	4
C135	47pF, 0603, NPO, 50V, 5%	Samsung	CL10C470JBNC	4
C136	47pF, 0603, NPO, 50V, 5%	Samsung	CL10C470JBNC	4
C139	47pF, 0603, NPO, 50V, 5%	Samsung	CL10C470JBNC	4
C140	47pF, 0603, NPO, 50V, 5%	Samsung	CL10C470JBNC	4
C141	47pF, 0603, NPO, 50V, 5%	Samsung	CL10C470JBNC	4
C142	47pF, 0603, NPO, 50V, 5%	Samsung	CL10C470JBNC	4
C143	47pF, 0603, NPO, 50V, 5%	Samsung	CL10C470JBNC	4
C144	47pF, 0603, NPO, 50V, 5%	Samsung	CL10C470JBNC	4
C145	10uF, BI-POLAR, 16V, 40C, 20%	ELNA	RVB16V100M-R	4
C146	100pF, 0603, NPO, 50V, 5%	Samsung	CL10C101JBNC	4
C147	100pF, 0603, NPO, 50V, 5%	Samsung	CL10C101JBNC	4
C148	100pF, 0603, NPO, 50V, 5%	Samsung	CL10C101JBNC	4
C149	10uF, BI-POLAR, 16V, 40C, 20%	ELNA	RVB16V100M-R	4
C200	0.1uF, 0603, Y5V, 50V, 20%	Samsung	CL10F104ZBNC	4
C201	10uF, ELEC, 16V, 40C, 20%	NICHICON	UZT1C100MCR1GB	4
C202	0.1uF, 0603, Y5V, 50V, 20%	Samsung	CL10F104ZBNC	4
C203	0.1uF, 0603, Y5V, 50V, 20%	Samsung	CL10F104ZBNC	4
C204	10uF, ELEC, 16V, 40C, 20%	NICHICON	UZT1C100MCR1GB	4
C205	0.1uF, 0603, Y5V, 50V, 20%	Samsung	CL10F104ZBNC	4
C208	0.1uF, 0603, Y5V, 50V, 20%	Samsung	CL10F104ZBNC	4
C209	0.1uF, 0603, Y5V, 50V, 20%	Samsung	CL10F104ZBNC	4
C210	0.1uF, 0603, Y5V, 50V, 20%	Samsung	CL10F104ZBNC	4
C211	0.1uF, 0603, Y5V, 50V, 20%	Samsung	CL10F104ZBNC	4
C212	0.1uF, 0603, Y5V, 50V, 20%	Samsung	CL10F104ZBNC	4
C213	0.1uF, 0603, Y5V, 50V, 20%	Samsung	CL10F104ZBNC	4
C214	0.1uF, 0603, Y5V, 50V, 20%	Samsung	CL10F104ZBNC	4
C215	0.1uF, 0603, Y5V, 50V, 20%	Samsung	CL10F104ZBNC	4
C216	0.1uF, 0603, Y5V, 50V, 20%	Samsung	CL10F104ZBNC	4
C217	0.1uF, 0603, Y5V, 50V, 20%	Samsung	CL10F104ZBNC	4
C218	47uF, ELEC, 16V, 40C, 20%	NICHICON	UZT1C470MCR1GB	4
C219	47uF, ELEC, 16V, 40C, 20%	NICHICON	UZT1C470MCR1GB	4
C220	47uF, ELEC, 16V, 40C, 20%	NICHICON	UZT1C470MCR1GB	4
C221	47uF, ELEC, 16V, 40C, 20%	NICHICON	UZT1C470MCR1GB	4
C222	10uF, ELEC, 16V, 40C, 20%	NICHICON	UZT1C100MCR1GB	4
C223	10uF, ELEC, 16V, 40C, 20%	NICHICON	UZT1C100MCR1GB	4
C224	10uF, ELEC, 16V, 40C, 20%	NICHICON	UZT1C100MCR1GB	4
C225	10uF, ELEC, 16V, 40C, 20%	NICHICON	UZT1C100MCR1GB	4
C226	10uF, BI-POLAR, 16V, 40C, 20%	ELNA	RVB16V100M-R	4
C227	100pF, 0603, NPO, 50V, 5%	Samsung	CL10C101JBNC	4
C228	100pF, 0603, NPO, 50V, 5%	Samsung	CL10C101JBNC	4
C229	100pF, 0603, NPO, 50V, 5%	Samsung	CL10C101JBNC	4

# ELECTRICAL PART LIST

ESP-88 Chassis 4x4 PCB Assembly

Capacitors (continued)

Reference Designator	Description	Vendor Name	Vendor Part Number	Note
C230	10uF, BI-POLAR, 16V, 40C, 20%	ELNA	RVB16V100M-R	4
C231	47pF, 0603, NPO, 50V, 5%	Samsung	CL10C470JBNC	4
C232	47pF, 0603, NPO, 50V, 5%	Samsung	CL10C470JBNC	4
C233	47pF, 0603, NPO, 50V, 5%	Samsung	CL10C470JBNC	4
C234	47pF, 0603, NPO, 50V, 5%	Samsung	CL10C470JBNC	4
C235	47pF, 0603, NPO, 50V, 5%	Samsung	CL10C470JBNC	4
C236	47pF, 0603, NPO, 50V, 5%	Samsung	CL10C470JBNC	4
C239	47pF, 0603, NPO, 50V, 5%	Samsung	CL10C470JBNC	4
C240	47pF, 0603, NPO, 50V, 5%	Samsung	CL10C470JBNC	4
C241	47pF, 0603, NPO, 50V, 5%	Samsung	CL10C470JBNC	4
C242	47pF, 0603, NPO, 50V, 5%	Samsung	CL10C470JBNC	4
C243	47pF, 0603, NPO, 50V, 5%	Samsung	CL10C470JBNC	4
C244	47pF, 0603, NPO, 50V, 5%	Samsung	CL10C470JBNC	4
C245	10uF, BI-POLAR, 16V, 40C, 20%	ELNA	RVB16V100M-R	4
C246	100pF, 0603, NPO, 50V, 5%	Samsung	CL10C101JBNC	4
C247	100pF, 0603, NPO, 50V, 5%	Samsung	CL10C101JBNC	4
C248	100pF, 0603, NPO, 50V, 5%	Samsung	CL10C101JBNC	4
C249	10uF, BI-POLAR, 16V, 40C, 20%	ELNA	RVB16V100M-R	4
C300	0.1uF, 0603, Y5V, 50V, 20%	Samsung	CL10F104ZBNC	4
C301	0.1uF, 0603, Y5V, 50V, 20%	Samsung	CL10F104ZBNC	4
C302	47uF, ELEC, 16V, 40C, 20%	NICHICON	UZT1C470MCR1GB	4
C303	47uF, ELEC, 16V, 40C, 20%	NICHICON	UZT1C470MCR1GB	4
C304	47uF, ELEC, 16V, 40C, 20%	NICHICON	UZT1C470MCR1GB	4
C305	47uF, ELEC, 16V, 40C, 20%	NICHICON	UZT1C470MCR1GB	4
C306	10uF, ELEC, 16V, 40C, 20%	NICHICON	UZT1C100MCR1GB	4
C307	10uF, BI-POLAR, 16V, 40C, 20%	ELNA	RVB16V100M-R	4
C308	100pF, 0603, NPO, 50V, 5%	Samsung	CL10C101JBNC	4
C309	0.01uF, 0603, X7R, 50V, 10%	Samsung	CL10B103KBNC	4
C310	0.01uF, 0603, X7R, 50V, 10%	Samsung	CL10B103KBNC	4
C311	220pF, 0603, X7R, 50V, 10%	Samsung	CL10B221KBNC	4
C312	220pF, 0603, X7R, 50V, 10%	Samsung	CL10B221KBNC	4
C313	220pF, 0603, X7R, 50V, 10%	Samsung	CL10B221KBNC	4
C314	220pF, 0603, X7R, 50V, 10%	Samsung	CL10B221KBNC	4
C315	22pF, 0603, NPO, 50V, 5%	Samsung	CL10C220JBNC	4
C316	22pF, 0603, NPO, 50V, 5%	Samsung	CL10C220JBNC	4
C317	0.1uF, 0603, Y5V, 50V, 20%	Samsung	CL10F104ZBNC	4
C318	0.1uF, 0603, Y5V, 50V, 20%	Samsung	CL10F104ZBNC	4
C319	0.1uF, 0603, Y5V, 50V, 20%	Samsung	CL10F104ZBNC	4
C320	0.1uF, 0603, Y5V, 50V, 20%	Samsung	CL10F104ZBNC	4
C321	2700pF, 0603, X7R, 50V, 10%	Samsung	CL10B272KBNC	4
C322	6800pF, 0603, X7R, 50V, 10%	Samsung	CL10B682KBNC	4
C323	470pF, 0603, X7R, 50V, 10%	Samsung	CL10B471KBNC	4
C324	1500pF, 0603, X7R, 50V, 10%	Samsung	CL10B152KBNC	4
C325	10uF, ELEC, 16V, 40C, 20%	NICHICON	UZT1C100MCR1GB	4
C326	10uF, ELEC, 16V, 40C, 20%	NICHICON	UZT1C100MCR1GB	4
C327	10uF, BI-POLAR, 16V, 40C, 20%	ELNA	RVB16V100M-R	4
C328	100pF, 0603, NPO, 50V, 5%	Samsung	CL10C101JBNC	4

# ELECTRICAL PART LIST

ESP-88 Chassis 4x4 PCB Assembly

Capacitors (continued)

Reference Designator	Description	Vendor Name	Vendor Part Number	Note
C329	0.01uF, 0603, X7R, 50V, 10%	Samsung	CL10B103KBNC	4
C330	0.01uF, 0603, X7R, 50V, 10%	Samsung	CL10B103KBNC	4
C331	220pF, 0603, X7R, 50V, 10%	Samsung	CL10B221KBNC	4
C332	220pF, 0603, X7R, 50V, 10%	Samsung	CL10B221KBNC	4
C333	220pF, 0603, X7R, 50V, 10%	Samsung	CL10B221KBNC	4
C334	220pF, 0603, X7R, 50V, 10%	Samsung	CL10B221KBNC	4
C335	22pF, 0603, NPO, 50V, 5%	Samsung	CL10C220JBNC	4
C336	22pF, 0603, NPO, 50V, 5%	Samsung	CL10C220JBNC	4
C337	0.1uF, 0603, Y5V, 50V, 20%	Samsung	CL10F104ZBNC	4
C338	0.1uF, 0603, Y5V, 50V, 20%	Samsung	CL10F104ZBNC	4
C339	0.1uF, 0603, Y5V, 50V, 20%	Samsung	CL10F104ZBNC	4
C340	0.1uF, 0603, Y5V, 50V, 20%	Samsung	CL10F104ZBNC	4
C341	2700pF, 0603, X7R, 50V, 10%	Samsung	CL10B272KBNC	4
C342	6800pF, 0603, X7R, 50V, 10%	Samsung	CL10B682KBNC	4
C343	470pF, 0603, X7R, 50V, 10%	Samsung	CL10B471KBNC	4
C344	1500pF, 0603, X7R, 50V, 10%	Samsung	CL10B152KBNC	4
C345	10uF, ELEC, 16V, 40C, 20%	NICHICON	Uzt1C100MCR1GB	4
C350	0.1uF, 0603, Y5V, 50V, 20%	Samsung	CL10F104ZBNC	4
C351	0.1uF, 0603, Y5V, 50V, 20%	Samsung	CL10F104ZBNC	4
C400	0.1uF, 0603, Y5V, 50V, 20%	Samsung	CL10F104ZBNC	4
C401	0.1uF, 0603, Y5V, 50V, 20%	Samsung	CL10F104ZBNC	4
C402	47uF, ELEC, 16V, 40C, 20%	NICHICON	Uzt1C470MCR1GB	4
C403	47uF, ELEC, 16V, 40C, 20%	NICHICON	Uzt1C470MCR1GB	4
C404	47uF, ELEC, 16V, 40C, 20%	NICHICON	Uzt1C470MCR1GB	4
C405	47uF, ELEC, 16V, 40C, 20%	NICHICON	Uzt1C470MCR1GB	4
C406	10uF, ELEC, 16V, 40C, 20%	NICHICON	Uzt1C100MCR1GB	4
C407	10uF, BI-POLAR, 16V, 40C, 20%	ELNA	RVB16V100M-R	4
C408	100pF, 0603, NPO, 50V, 5%	Samsung	CL10C101JBNC	4
C409	0.01uF, 0603, X7R, 50V, 10%	Samsung	CL10B103KBNC	4
C410	0.01uF, 0603, X7R, 50V, 10%	Samsung	CL10B103KBNC	4
C411	220pF, 0603, X7R, 50V, 10%	Samsung	CL10B221KBNC	4
C412	220pF, 0603, X7R, 50V, 10%	Samsung	CL10B221KBNC	4
C413	220pF, 0603, X7R, 50V, 10%	Samsung	CL10B221KBNC	4
C414	220pF, 0603, X7R, 50V, 10%	Samsung	CL10B221KBNC	4
C415	22pF, 0603, NPO, 50V, 5%	Samsung	CL10C220JBNC	4
C416	22pF, 0603, NPO, 50V, 5%	Samsung	CL10C220JBNC	4
C417	0.1uF, 0603, Y5V, 50V, 20%	Samsung	CL10F104ZBNC	4
C418	0.1uF, 0603, Y5V, 50V, 20%	Samsung	CL10F104ZBNC	4
C419	0.1uF, 0603, Y5V, 50V, 20%	Samsung	CL10F104ZBNC	4
C420	0.1uF, 0603, Y5V, 50V, 20%	Samsung	CL10F104ZBNC	4
C421	2700pF, 0603, X7R, 50V, 10%	Samsung	CL10B272KBNC	4
C422	6800pF, 0603, X7R, 50V, 10%	Samsung	CL10B682KBNC	4
C423	470pF, 0603, X7R, 50V, 10%	Samsung	CL10B471KBNC	4
C424	1500pF, 0603, X7R, 50V, 10%	Samsung	CL10B152KBNC	4
C425	10uF, ELEC, 16V, 40C, 20%	NICHICON	Uzt1C100MCR1GB	4
C426	10uF, ELEC, 16V, 40C, 20%	NICHICON	Uzt1C100MCR1GB	4
C427	10uF, BI-POLAR, 16V, 40C, 20%	ELNA	RVB16V100M-R	4

# ELECTRICAL PART LIST

ESP-88 Chassis 4x4 PCB Assembly

Capacitors (continued)

Reference Designator	Description	Vendor Name	Vendor Part Number	Note
C428	100pF, 0603, NPO, 50V, 5%	Samsung	CL10C101JBNC	4
C429	0.01uF, 0603, X7R, 50V, 10%	Samsung	CL10B103KBNC	4
C430	0.01uF, 0603, X7R, 50V, 10%	Samsung	CL10B103KBNC	4
C431	220pF, 0603, X7R, 50V, 10%	Samsung	CL10B221KBNC	4
C432	220pF, 0603, X7R, 50V, 10%	Samsung	CL10B221KBNC	4
C433	220pF, 0603, X7R, 50V, 10%	Samsung	CL10B221KBNC	4
C434	220pF, 0603, X7R, 50V, 10%	Samsung	CL10B221KBNC	4
C435	22pF, 0603, NPO, 50V, 5%	Samsung	CL10C220JBNC	4
C436	22pF, 0603, NPO, 50V, 5%	Samsung	CL10C220JBNC	4
C437	0.1uF, 0603, Y5V, 50V, 20%	Samsung	CL10F104ZBNC	4
C438	0.1uF, 0603, Y5V, 50V, 20%	Samsung	CL10F104ZBNC	4
C439	0.1uF, 0603, Y5V, 50V, 20%	Samsung	CL10F104ZBNC	4
C440	0.1uF, 0603, Y5V, 50V, 20%	Samsung	CL10F104ZBNC	4
C441	2700pF, 0603, X7R, 50V, 10%	Samsung	CL10B272KBNC	4
C442	6800pF, 0603, X7R, 50V, 10%	Samsung	CL10B682KBNC	4
C443	470pF, 0603, X7R, 50V, 10%	Samsung	CL10B471KBNC	4
C444	1500pF, 0603, X7R, 50V, 10%	Samsung	CL10B152KBNC	4
C445	10uF, ELEC, 16V, 40C, 20%	NICHICON	UZT1C100MCR1GB	4
C450	0.1uF, 0603, Y5V, 50V, 20%	Samsung	CL10F104ZBNC	4
C451	0.1uF, 0603, Y5V, 50V, 20%	Samsung	CL10F104ZBNC	4
C500	47uF, ELEC, 16V, 40C, 20%	NICHICON	UZT1C470MCR1GB	4
C501	0.1uF, 0603, Y5V, 50V, 20%	Samsung	CL10F104ZBNC	4
C502	10uF, ELEC, 16V, 40C, 20%	NICHICON	UZT1C100MCR1GB	4
C503	0.1uF, 0603, Y5V, 50V, 20%	Samsung	CL10F104ZBNC	4
C504	47uF, ELEC, 16V, 40C, 20%	NICHICON	UZT1C470MCR1GB	4
C505	0.1uF, 0603, Y5V, 50V, 20%	Samsung	CL10F104ZBNC	4
C506	560pF, 0603, X7R, 50V, 10%	Samsung	CL10B561KBNC	4
C507	560pF, 0603, X7R, 50V, 10%	Samsung	CL10B561KBNC	4
C508	10uF, ELEC, 16V, 40C, 20%	NICHICON	UZT1C100MCR1GB	4
C509	0.1uF, 0603, Y5V, 50V, 20%	Samsung	CL10F104ZBNC	4
C510	10uF, ELEC, 16V, 40C, 20%	NICHICON	UZT1C100MCR1GB	4
C511	0.1uF, 0603, Y5V, 50V, 20%	Samsung	CL10F104ZBNC	4
C512	0.1uF, 0603, Y5V, 50V, 20%	Samsung	CL10F104ZBNC	4
C513	10uF, ELEC, 16V, 40C, 20%	NICHICON	UZT1C100MCR1GB	4
C514	0.1uF, 0603, Y5V, 50V, 20%	Samsung	CL10F104ZBNC	4
C515	10uF, ELEC, 16V, 40C, 20%	NICHICON	UZT1C100MCR1GB	4
C516	560pF, 0603, X7R, 50V, 10%	Samsung	CL10B561KBNC	4
C517	560pF, 0603, X7R, 50V, 10%	Samsung	CL10B561KBNC	4
C518	0.1uF, 0603, Y5V, 50V, 20%	Samsung	CL10F104ZBNC	4
C519	47uF, ELEC, 16V, 40C, 20%	NICHICON	UZT1C470MCR1GB	4
C520	0.1uF, 0603, Y5V, 50V, 20%	Samsung	CL10F104ZBNC	4
C521	10uF, ELEC, 16V, 40C, 20%	NICHICON	UZT1C100MCR1GB	4
C522	0.1uF, 0603, Y5V, 50V, 20%	Samsung	CL10F104ZBNC	4
C523	47uF, ELEC, 16V, 40C, 20%	NICHICON	UZT1C470MCR1GB	4
C524	47pF, 0603, NPO, 50V, 5%	Samsung	CL10C470JBNC	4
C525	47pF, 0603, NPO, 50V, 5%	Samsung	CL10C470JBNC	4
C526	47pF, 0603, NPO, 50V, 5%	Samsung	CL10C470JBNC	4



# ELECTRICAL PART LIST

ESP-88 Chassis 4x4 PCB Assembly

Capacitors (continued)

Reference Designator	Description	Vendor Name	Vendor Part Number	Note
C527	47pF, 0603, NPO, 50V, 5%	Samsung	CL10C470JBNC	4
C528	47pF, 0603, NPO, 50V, 5%	Samsung	CL10C470JBNC	4
C529	47pF, 0603, NPO, 50V, 5%	Samsung	CL10C470JBNC	4
C550	10uF, ELEC, 16V, 40C, 20%	NICHICON	UZT1C100MCR1GB	4
C551	0.1uF, 0603, Y5V, 50V, 20%	Samsung	CL10F104ZBNC	4
C552	47uF, ELEC, 16V, 40C, 20%	NICHICON	UZT1C470MCR1GB	4
C553	0.1uF, 0603, Y5V, 50V, 20%	Samsung	CL10F104ZBNC	4
C554	10uF, ELEC, 16V, 40C, 20%	NICHICON	UZT1C100MCR1GB	4
C555	0.1uF, 0603, Y5V, 50V, 20%	Samsung	CL10F104ZBNC	4
C556	10uF, ELEC, 16V, 40C, 20%	NICHICON	UZT1C100MCR1GB	4
C557	0.1uF, 0603, Y5V, 50V, 20%	Samsung	CL10F104ZBNC	4
C558	0.1uF, 0603, Y5V, 50V, 20%	Samsung	CL10F104ZBNC	4
C559	10uF, ELEC, 16V, 40C, 20%	NICHICON	UZT1C100MCR1GB	4
C560	0.1uF, 0603, Y5V, 50V, 20%	Samsung	CL10F104ZBNC	4
C561	10uF, ELEC, 16V, 40C, 20%	NICHICON	UZT1C100MCR1GB	4
C562	0.1uF, 0603, Y5V, 50V, 20%	Samsung	CL10F104ZBNC	4
C563	47uF, ELEC, 16V, 40C, 20%	NICHICON	UZT1C470MCR1GB	4
C564	0.1uF, 0603, Y5V, 50V, 20%	Samsung	CL10F104ZBNC	4
C565	10uF, ELEC, 16V, 40C, 20%	NICHICON	UZT1C100MCR1GB	4
C566	47pF, 0603, NPO, 50V, 5%	Samsung	CL10C470JBNC	4
C567	47pF, 0603, NPO, 50V, 5%	Samsung	CL10C470JBNC	4
C568	47pF, 0603, NPO, 50V, 5%	Samsung	CL10C470JBNC	4
C569	47pF, 0603, NPO, 50V, 5%	Samsung	CL10C470JBNC	4
C570	47pF, 0603, NPO, 50V, 5%	Samsung	CL10C470JBNC	4
C571	47pF, 0603, NPO, 50V, 5%	Samsung	CL10C470JBNC	4
C572	47pF, 0603, NPO, 50V, 5%	Samsung	CL10C470JBNC	4
C573	47pF, 0603, NPO, 50V, 5%	Samsung	CL10C470JBNC	4
C700	0.1uF, 0603, Y5V, 50V, 20%	Samsung	CL10F104ZBNC	4
C701	0.1uF, 0603, Y5V, 50V, 20%	Samsung	CL10F104ZBNC	4
C702	0.1uF, 0603, Y5V, 50V, 20%	Samsung	CL10F104ZBNC	4
C703	10uF, ELEC, 16V, 40C, 20%	NICHICON	UZT1C100MCR1GB	4
C704	0.1uF, 0603, Y5V, 50V, 20%	Samsung	CL10F104ZBNC	4
C705	0.1uF, 0603, Y5V, 50V, 20%	Samsung	CL10F104ZBNC	4
C706	10uF, ELEC, 16V, 40C, 20%	NICHICON	UZT1C100MCR1GB	4
C707	10uF, ELEC, 16V, 40C, 20%	NICHICON	UZT1C100MCR1GB	4
C708	0.1uF, 0603, Y5V, 50V, 20%	Samsung	CL10F104ZBNC	4
C709	10uF, ELEC, 16V, 40C, 20%	NICHICON	UZT1C100MCR1GB	4
C710	0.1uF, 0603, Y5V, 50V, 20%	Samsung	CL10F104ZBNC	4
C711	12pF, 0603, NPO, 50V, 5%	Samsung	CL10C120JBNC	4
C712	12pF, 0603, NPO, 50V, 5%	Samsung	CL10C120JBNC	4
C713	0.1uF, 0603, Y5V, 50V, 20%	Samsung	CL10F104ZBNC	4
C714	0.1uF, 0603, Y5V, 50V, 20%	Samsung	CL10F104ZBNC	4
C715	10uF, ELEC, 16V, 40C, 20%	NICHICON	UZT1C100MCR1GB	4
C716	0.1uF, 0603, Y5V, 50V, 20%	Samsung	CL10F104ZBNC	4
C717	0.1uF, 0603, Y5V, 50V, 20%	Samsung	CL10F104ZBNC	4
C718	0.1uF, 0603, Y5V, 50V, 20%	Samsung	CL10F104ZBNC	4
C719	0.1uF, 0603, Y5V, 50V, 20%	Samsung	CL10F104ZBNC	4

# ELECTRICAL PART LIST

ESP-88 Chassis 4x4 PCB Assembly

Capacitors (continued)

Reference Designator	Description	Vendor Name	Vendor Part Number	Note
C720	47pF, 0603, NPO, 50V, 5%	Samsung	CL10C470JBNC	4
C721	47pF, 0603, NPO, 50V, 5%	Samsung	CL10C470JBNC	4
C722	47pF, 0603, NPO, 50V, 5%	Samsung	CL10C470JBNC	4
C723	47pF, 0603, NPO, 50V, 5%	Samsung	CL10C470JBNC	4

Inductors

Reference Designator	Description	Vendor Name	Vendor Part Number	Note
L100	EMI FILTER, 50V, 300mA, 20%	Murata	NFM21CC223R1H3D	4
L101	EMI FILTER, 50V, 300mA, 20%	Murata	NFM21CC223R1H3D	4
L102	EMI FILTER, 50V, 300mA, 20%	Murata	NFM21CC223R1H3D	4
L103	EMI FILTER, 50V, 300mA, 20%	Murata	NFM21CC223R1H3D	4
L104	EMI FILTER, 50V, 300mA, 20%	Murata	NFM21CC223R1H3D	4
L105	EMI FILTER, 50V, 300mA, 20%	Murata	NFM21CC223R1H3D	4
L200	EMI FILTER, 50V, 300mA, 20%	Murata	NFM21CC223R1H3D	4
L201	EMI FILTER, 50V, 300mA, 20%	Murata	NFM21CC223R1H3D	4
L202	EMI FILTER, 50V, 300mA, 20%	Murata	NFM21CC223R1H3D	4
L203	EMI FILTER, 50V, 300mA, 20%	Murata	NFM21CC223R1H3D	4
L204	EMI FILTER, 50V, 300mA, 20%	Murata	NFM21CC223R1H3D	4
L205	EMI FILTER, 50V, 300mA, 20%	Murata	NFM21CC223R1H3D	4

Diodes

Reference Designator	Description	Vendor Name	Vendor Part Number	Note
D100	DIODE, SWITCHING, SC-59	Rohm	DAN217	4
D101	DIODE, SWITCHING, SC-59	Rohm	DAN217	4
D102	DIODE, SWITCHING, SC-59	Rohm	DAN217	4
D103	DIODE, SWITCHING, SC-59	Rohm	DAN217	4
D200	DIODE, SWITCHING, SC-59	Rohm	DAN217	4
D201	DIODE, SWITCHING, SC-59	Rohm	DAN217	4
D202	DIODE, SWITCHING, SC-59	Rohm	DAN217	4
D203	DIODE, SWITCHING, SC-59	Rohm	DAN217	4
D300	DIODE, SWITCHING, SC-59	Rohm	DAN217	4
D301	DIODE, SWITCHING, SC-59	Rohm	DAN217	4
D302	DIODE, SWITCHING, SC-59	Rohm	DAN217	4
D303	DIODE, SWITCHING, SC-59	Rohm	DAN217	4
D400	DIODE, SWITCHING, SC-59	Rohm	DAN217	4
D401	DIODE, SWITCHING, SC-59	Rohm	DAN217	4
D402	DIODE, SWITCHING, SC-59	Rohm	DAN217	4
D403	DIODE, SWITCHING, SC-59	Rohm	DAN217	4
D700	RECT, 400V, 1A, SOD-106	Rohm	1SR154-400	4
D701	RECT, 400V, 1A, SOD-106	Rohm	1SR154-400	4



# ELECTRICAL PART LIST

ESP-88 Chassis 4x4 PCB Assembly

Transistors

Reference Designator	Description	Vendor Name	Vendor Part Number	Note
Q100	NPN 50V, 100mA, SOT-23	KEC	KRC102S	4
Q101	NPN 50V, 100mA, SOT-23	KEC	KRC102S	4
Q102	PNP, 50V, 100mA, SOT-23	KEC	KRA102S	4
Q103	PNP, 50V, 100mA, SOT-23	KEC	KRA102S	4
Q200	NPN 50V, 100mA, SOT-23	KEC	KRC102S	4
Q201	NPN 50V, 100mA, SOT-23	KEC	KRC102S	4
Q202	PNP, 50V, 100mA, SOT-23	KEC	KRA102S	4
Q203	PNP, 50V, 100mA, SOT-23	KEC	KRA102S	4
Q300	NPN 50V, 100mA, SOT-23	KEC	KRC102S	4
Q301	NPN 50V, 100mA, SOT-23	KEC	KRC102S	4
Q302	NPN, 20V, 300mA, SC-59	Toshiba	2SC3326-B	4
Q303	NPN, 20V, 300mA, SC-59	Toshiba	2SC3326-B	4
Q304	NPN 50V, 100mA, SOT-23	KEC	KRC102S	4
Q305	NPN 50V, 100mA, SOT-23	KEC	KRC102S	4
Q306	NPN 50V, 100mA, SOT-23	KEC	KRC102S	4
Q307	NPN 50V, 100mA, SOT-23	KEC	KRC102S	4
Q308	NPN, 20V, 300mA, SC-59	Toshiba	2SC3326-B	4
Q309	NPN, 20V, 300mA, SC-59	Toshiba	2SC3326-B	4
Q310	NPN, 20V, 300mA, SC-59	Toshiba	2SC3326-B	4
Q311	NPN, 20V, 300mA, SC-59	Toshiba	2SC3326-B	4
Q312	PNP, 50V, 100mA, SOT-23	KEC	KRA102S	4
Q313	NPN 50V, 100mA, SOT-23	KEC	KRC102S	4
Q314	PNP, 50V, 100mA, SOT-23	KEC	KRA102S	4
Q315	NPN 50V, 100mA, SOT-23	KEC	KRC102S	4
Q400	NPN 50V, 100mA, SOT-23	KEC	KRC102S	4
Q401	NPN 50V, 100mA, SOT-23	KEC	KRC102S	4
Q402	NPN, 20V, 300mA, SC-59	Toshiba	2SC3326-B	4
Q403	NPN, 20V, 300mA, SC-59	Toshiba	2SC3326-B	4
Q404	NPN 50V, 100mA, SOT-23	KEC	KRC102S	4
Q405	NPN 50V, 100mA, SOT-23	KEC	KRC102S	4
Q406	NPN 50V, 100mA, SOT-23	KEC	KRC102S	4
Q407	NPN 50V, 100mA, SOT-23	KEC	KRC102S	4
Q408	NPN, 20V, 300mA, SC-59	Toshiba	2SC3326-B	4
Q409	NPN, 20V, 300mA, SC-59	Toshiba	2SC3326-B	4
Q410	NPN, 20V, 300mA, SC-59	Toshiba	2SC3326-B	4
Q411	NPN, 20V, 300mA, SC-59	Toshiba	2SC3326-B	4
Q412	PNP, 50V, 100mA, SOT-23	KEC	KRA102S	4
Q413	NPN 50V, 100mA, SOT-23	KEC	KRC102S	4
Q414	PNP, 50V, 100mA, SOT-23	KEC	KRA102S	4
Q415	NPN 50V, 100mA, SOT-23	KEC	KRC102S	4
Q700	NPN 50V, 100mA, SOT-23	KEC	KRC102S	4
Q702	NPN 50V, 100mA, SOT-23	KEC	KRC102S	4
Q703	NPN 50V, 100mA, SOT-23	KEC	KRC102S	4
Q704	NPN 50V, 100mA, SOT-23	KEC	KRC102S	4
Q705	NPN 50V, 100mA, SOT-23	KEC	KRC102S	4

# ELECTRICAL PART LIST

ESP-88 Chassis 4x4 PCB Assembly

Integrated Circuits

Reference Designator	Description	Vendor Name	Vendor Part Number	Note
M100	HI-VOLTAGE ANALOG SW ARRAY, SOP28	Toshiba	TC9164CFG	4
M100	ANALOG SW ARRAY, SOP28	Toshiba	TC9164AF	4
M101	OP-AMP, SSOP8	JRC	NJM4580ETE2	4
M102	OP-AMP, SSOP8	JRC	NJM4580ETE2	4
M103	OP-AMP, SSOP8	JRC	NJM4580ETE2	4
M104	OP-AMP, SSOP8	JRC	NJM4580ETE2	4
M200	HI-VOLTAGE ANALOG SW ARRAY, SOP28	Toshiba	TC9164CFG	4
M200	ANALOG SW ARRAY, SOP28	Toshiba	TC9164AF	4
M201	OP-AMP, SSOP8	JRC	NJM4580ETE2	4
M202	OP-AMP, SSOP8	JRC	NJM4580ETE2	4
M203	OP-AMP, SSOP8	JRC	NJM4580ETE2	4
M204	OP-AMP, SSOP8	JRC	NJM4580ETE2	4
M300	OP-AMP, SSOP8	JRC	NJM4580ETE2	4
M301	OP-AMP, SSOP8	JRC	NJM4580ETE2	4
M302	OP-AMP, SSOP8	JRC	NJM4580ETE2	4
M303	OP-AMP, SSOP8	JRC	NJM4580ETE2	4
M400	OP-AMP, SSOP8	JRC	NJM4580ETE2	4
M401	OP-AMP, SSOP8	JRC	NJM4580ETE2	4
M402	OP-AMP, SSOP8	JRC	NJM4580ETE2	4
M403	OP-AMP, SSOP8	JRC	NJM4580ETE2	4
M500	AUDIO ADC, TSSOP24	Cirrus	CS5361-KZ	4
M500	A/D CONVERTER, TSSOP24, LEAD FREE	Cirrus	CS5361-KZ	4
M501	AUDIO ADC, TSSOP24	Cirrus	CS5361-KZ	4
M501	A/D CONVERTER, TSSOP24, LEAD FREE	Cirrus	CS5361-KZ	4
M550	DAC, STEREO, TSSOP-20	Cirrus	CS4392-KZ	4
M551	DAC, STEREO, TSSOP-20	Cirrus	CS4392-KZ	4
M700	OCTAL BUFFER DRIVER, TSSOP20	ONSemi	MC74VHC541DT	4
M701	OCTAL BUFFER DRIVER, TSSOP20	ONSemi	MC74VHC541DT	4
M702	OCTAL D-TYPE FLIP-FLOP, TSSOP20	ONSEMI	MC74AC273DT	4
M703	VOLT DET, Vd=3.0V	ONSEMI	NCP303LSN30T1	4
M703	VOLT DET, Vd=3.0V	SEIKO	S-80930CNMC-G80-T2	4
M704	REG, 3.3V, 1A, TO-252	NEC	UPC2933T	4
M705	REG, 5.0V, DPAK	KEC	KIA7805AF	4
M706	FLASH, MCU, 32K, LQFP64	RENASES	HD64F3664FP	4
M707	OCTAL D-TYPE FLIP-FLOP, TSSOP20	ONSEMI	MC74AC273DT	4
M708	OCTAL BUFFER DRIVER, TSSOP20	ONSemi	MC74VHC541DT	4

# ELECTRICAL PART LIST

ESP-88 Chassis 4x4 PCB Assembly

Miscellaneous

<b>Reference Designator</b>	<b>Description</b>	<b>Vendor Name</b>	<b>Vendor Part Number</b>	<b>Note</b>
CN100	HEADER, P5.08, 3 POLE, RGT ANG	DINKLE	2EHDRC-03P	4
CN101	HEADER, P5.08, 3 POLE, RGT ANG	DINKLE	2EHDRC-03P	4
CN200	HEADER, P5.08, 3 POLE, RGT ANG	DINKLE	2EHDRC-03P	4
CN201	HEADER, P5.08, 3 POLE, RGT ANG	DINKLE	2EHDRC-03P	4
CN600	HEADER, P2.5MM, 9 POLES	NELTRON	2317SJ-09	4
CN700	B-B CONN, 30 PIN, 1MM	KEL	87BFN-030R	4
XTAL700	10.000MHz, 30ppm, 20pF, HC-49/S	Raltron	AS-10.000-20	4

# ELECTRICAL PART LIST

ESP-88 Digital Signal Processor (DSP) PCB Assembly

Resistors

Reference Designator	Description	Vendor	Vendor Part Number	Note
R100	33 OHM, 0603, 1/10W, 1%	Yageo	RC0603FR-0733R	4
R101	1K, 0603, 1/10W, 1%	Yageo	RC0603FR-071K	4
R102	1K, 0603, 1/10W, 1%	Yageo	RC0603FR-071K	4
R103	10K, 0603, 1/10W, 1%	Yageo	RC0603FR-0710K	4
R104	10K, 0603, 1/10W, 1%	Yageo	RC0603FR-0710K	4
R105	10K, 0603, 1/10W, 1%	Yageo	RC0603FR-0710K	4
R106	10K, 0603, 1/10W, 1%	Yageo	RC0603FR-0710K	4
R107	10K, 0603, 1/10W, 1%	Yageo	RC0603FR-0710K	4
R108	33 OHM, 0603, 1/10W, 1%	Yageo	RC0603FR-0733R	4
R109	110 OHM, 0603, 1/10W, 1%	Yageo	RC0603FR-07110R	4
R110	110 OHM, 0603, 1/10W, 1%	Yageo	RC0603FR-07110R	4
R111	110 OHM, 0603, 1/10W, 1%	Yageo	RC0603FR-07110R	4
R200	33 OHM, 0603, 1/10W, 1%	Yageo	RC0603FR-0733R	4
R201	33 OHM, 0603, 1/10W, 1%	Yageo	RC0603FR-0733R	4
R202	330 OHM, 0603, 1/10W, 1%	Yageo	RC0603FR-07330R	4
R203	33 OHM, 0603, 1/10W, 1%	Yageo	RC0603FR-0733R	4
R204	33 OHM, 0603, 1/10W, 1%	Yageo	RC0603FR-0733R	4
R205	33 OHM, 0603, 1/10W, 1%	Yageo	RC0603FR-0733R	4
R206	1K, 0603, 1/10W, 1%	Yageo	RC0603FR-071K	4
R208	33 OHM, 0603, 1/10W, 1%	Yageo	RC0603FR-0733R	4
R210	33 OHM, 0603, 1/10W, 1%	Yageo	RC0603FR-0733R	4
R211	10K, 0603, 1/10W, 1%	Yageo	RC0603FR-0710K	4
R212	33 OHM, 0603, 1/10W, 1%	Yageo	RC0603FR-0733R	4
R213	0 OHM, 0603, 1/10W, 5%	Yageo	RC0603JR-07R00	4
R214	0 OHM, 0603, 1/10W, 5%	Yageo	RC0603JR-07R00	4
R215	0 OHM, 0603, 1/10W, 5%	Yageo	RC0603JR-07R00	4
R216	0 OHM, 0603, 1/10W, 5%	Yageo	RC0603JR-07R00	4
R219	33 OHM, 0603, 1/10W, 1%	Yageo	RC0603FR-0733R	4
R220	33 OHM, 0603, 1/10W, 1%	Yageo	RC0603FR-0733R	4
R300	4.7K, 0603, 1/10W, 1%	Yageo	RC0603FR-074K7	4
R301	4.7K, 0603, 1/10W, 1%	Yageo	RC0603FR-074K7	4
R302	0 OHM, 0603, 1/10W, 5%	Yageo	RC0603JR-07R00	4
R303	0 OHM, 0603, 1/10W, 5%	Yageo	RC0603JR-07R00	4
R306	0 OHM, 0603, 1/10W, 5%	Yageo	RC0603JR-07R00	4
R307	4.7K, 0603, 1/10W, 1%	Yageo	RC0603FR-074K7	4
R309	4.7K, 0603, 1/10W, 1%	Yageo	RC0603FR-074K7	4
R310	4.7K, 0603, 1/10W, 1%	Yageo	RC0603FR-074K7	4
R311	4.7K, 0603, 1/10W, 1%	Yageo	RC0603FR-074K7	4
R312	0 OHM, 0603, 1/10W, 5%	Yageo	RC0603JR-07R00	4
R313	0 OHM, 0603, 1/10W, 5%	Yageo	RC0603JR-07R00	4
R316	0 OHM, 0603, 1/10W, 5%	Yageo	RC0603JR-07R00	4
R318	33 OHM, 0603, 1/10W, 1%	Yageo	RC0603FR-0733R	4
R321	33 OHM, 0603, 1/10W, 1%	Yageo	RC0603FR-0733R	4
R401	0 OHM, 0603, 1/10W, 5%	Yageo	RC0603JR-07R00	4
R402	4.7K, 0603, 1/10W, 1%	Yageo	RC0603FR-074K7	4
R403	8.2 OHM, 0603, 1/10W, 1%	Yageo	RC0603FR-078R2	4
R404	8.2 OHM, 0603, 1/10W, 1%	Yageo	RC0603FR-078R2	4
R407	5.1K, 0603, 1/10W, 1%	Yageo	RC0603FR-075K1	4
R408	100 OHM, 0603, 1/10W, 1%	Yageo	RC0603FR-07100R	4

# ELECTRICAL PART LIST

ESP-88 Digital Signal Processor (DSP) PCB Assembly

Resistors (continued)

Reference Designator	Description	Vendor	Vendor Part Number	Note
R409	10K, 0603, 1/10W, 1%	Yageo	RC0603FR-0710K	4
R410	220K, 0603, 1/10W, 1%	Yageo	RC0603FR-07220K	4
R450	4.7K, 0603, 1/10W, 1%	Yageo	RC0603FR-074K7	4
R451	4.7K, 0603, 1/10W, 1%	Yageo	RC0603FR-074K7	4
R452	560K, 0603, 1/10W, 1%	Yageo	RC0603FR-07560K	4
R457	180 OHM, 0603, 1/10W, 5%	Yageo	RC0603JR-07180R	4
R458	180 OHM, 0603, 1/10W, 5%	Yageo	RC0603JR-07180R	4
R459	180 OHM, 0603, 1/10W, 5%	Yageo	RC0603JR-07180R	4
R460	180 OHM, 0603, 1/10W, 5%	Yageo	RC0603JR-07180R	4
R461	180 OHM, 0603, 1/10W, 5%	Yageo	RC0603JR-07180R	4
R462	180 OHM, 0603, 1/10W, 5%	Yageo	RC0603JR-07180R	4
R463	180 OHM, 0603, 1/10W, 5%	Yageo	RC0603JR-07180R	4
R464	180 OHM, 0603, 1/10W, 5%	Yageo	RC0603JR-07180R	4
R465	4.7K, 0603, 1/10W, 1%	Yageo	RC0603FR-074K7	4
R466	10K, 0603, 1/10W, 1%	Yageo	RC0603FR-0710K	4
R467	0 OHM, 0603, 1/10W, 5%	Yageo	RC0603JR-07R00	4
R468	0 OHM, 0603, 1/10W, 5%	Yageo	RC0603JR-07R00	4
R469	0 OHM, 0603, 1/10W, 5%	Yageo	RC0603JR-07R00	4
R470	68K, 0603, 1/10W, 1%	Yageo	RC0603FR-0768K	4
R475	330 OHM, 0603, 1/10W, 1%	Yageo	RC0603FR-07330R	4
R476	820 OHM, 0603, 1/10W, 1%	Yageo	RC0603FR-07820R	4
R477	10K, 0603, 1/10W, 1%	Yageo	RC0603FR-0710K	4
R478	390 OHM, 0603, 1/10W, 1%	Yageo	RC0603FR-07390R	4
R479	820 OHM, 0603, 1/10W, 1%	Yageo	RC0603FR-07820R	4
R480	12K, 0603, 1/10W, 1%	Yageo	RC0603FR-0712K	4
R481	1.2K, 0603, 1/10W, 1%	Yageo	RC0603FR-071K2	4
R482	120 OHM, 0603, 1/10W, 1%	Yageo	RC0603FR-07120R	4
R483	1.2K, 0603, 1/10W, 1%	Yageo	RC0603FR-071K2	4
R535	0 OHM, 0603, 1/10W, 5%	Yageo	RC0603JR-07R00	4
R536	0 OHM, 0603, 1/10W, 5%	Yageo	RC0603JR-07R00	4
R537	0 OHM, 0603, 1/10W, 5%	Yageo	RC0603JR-07R00	4
R538	0 OHM, 0603, 1/10W, 5%	Yageo	RC0603JR-07R00	4
R539	33 OHM, 0603, 1/10W, 1%	Yageo	RC0603FR-0733R	4
R540	33 OHM, 0603, 1/10W, 1%	Yageo	RC0603FR-0733R	4
R541	33 OHM, 0603, 1/10W, 1%	Yageo	RC0603FR-0733R	4
R542	33 OHM, 0603, 1/10W, 1%	Yageo	RC0603FR-0733R	4

## Resistor Arrays

Reference Designator	Description	Vendor	Vendor Part Number	Note
RA100	10K, ARRAY, 10 PIN, 8R, 5%	Yageo	YC158TJR-0710K	4
RA101	33 OHM, ARRAY, 8 PIN, 5%	Yageo	YC164-JR-0733R	4
RA102	33 OHM, ARRAY, 8 PIN, 5%	Yageo	YC164-JR-0733R	4
RA103	33 OHM, ARRAY, 8 PIN, 5%	Yageo	YC164-JR-0733R	4
RA104	33 OHM, ARRAY, 8 PIN, 5%	Yageo	YC164-JR-0733R	4
RA105	33 OHM, ARRAY, 8 PIN, 5%	Yageo	YC164-JR-0733R	4
RA106	33 OHM, ARRAY, 8 PIN, 5%	Yageo	YC164-JR-0733R	4
RA107	33 OHM, ARRAY, 8 PIN, 5%	Yageo	YC164-JR-0733R	4
RA108	33 OHM, ARRAY, 8 PIN, 5%	Yageo	YC164-JR-0733R	4

# ELECTRICAL PART LIST

ESP-88 Digital Signal Processor (DSP) PCB Assembly

Resistor Arrays (continued)

Reference Designator	Description	Vendor	Vendor Part Number	Note
RA109	33 OHM, ARRAY, 8 PIN, 5%	Yageo	YC164-JR-0733R	4
RA110	33 OHM, ARRAY, 8 PIN, 5%	Yageo	YC164-JR-0733R	4
RA111	33 OHM, ARRAY, 8 PIN, 5%	Yageo	YC164-JR-0733R	4
RA200	10K, ARRAY, 10 PIN, 8R, 5%	Yageo	YC158TJR-0710K	4
RA201	33 OHM, ARRAY, 8 PIN, 5%	Yageo	YC164-JR-0733R	4
RA202	33 OHM, ARRAY, 8 PIN, 5%	Yageo	YC164-JR-0733R	4
RA203	33 OHM, ARRAY, 8 PIN, 5%	Yageo	YC164-JR-0733R	4
RA204	33 OHM, ARRAY, 8 PIN, 5%	Yageo	YC164-JR-0733R	4
RA205	33 OHM, ARRAY, 8 PIN, 5%	Yageo	YC164-JR-0733R	4
RA206	33 OHM, ARRAY, 8 PIN, 5%	Yageo	YC164-JR-0733R	4
RA207	33 OHM, ARRAY, 8 PIN, 5%	Yageo	YC164-JR-0733R	4
RA208	33 OHM, ARRAY, 8 PIN, 5%	Yageo	YC164-JR-0733R	4
RA209	33 OHM, ARRAY, 8 PIN, 5%	Yageo	YC164-JR-0733R	4
RA210	33 OHM, ARRAY, 8 PIN, 5%	Yageo	YC164-JR-0733R	4
RA211	33 OHM, ARRAY, 8 PIN, 5%	Yageo	YC164-JR-0733R	4
RA212	33 OHM, ARRAY, 8 PIN, 5%	Yageo	YC164-JR-0733R	4
RA213	33 OHM, ARRAY, 8 PIN, 5%	Yageo	YC164-JR-0733R	4
RA214	33 OHM, ARRAY, 8 PIN, 5%	Yageo	YC164-JR-0733R	4
RA215	33 OHM, ARRAY, 8 PIN, 5%	Yageo	YC164-JR-0733R	4
RA216	33 OHM, ARRAY, 8 PIN, 5%	Yageo	YC164-JR-0733R	4
RA217	33 OHM, ARRAY, 8 PIN, 5%	Yageo	YC164-JR-0733R	4
RA218	33 OHM, ARRAY, 8 PIN, 5%	Yageo	YC164-JR-0733R	4
RA219	33 OHM, ARRAY, 8 PIN, 5%	Yageo	YC164-JR-0733R	4
RA220	33 OHM, ARRAY, 8 PIN, 5%	Yageo	YC164-JR-0733R	4
RA221	33 OHM, ARRAY, 8 PIN, 5%	Yageo	YC164-JR-0733R	4
RA222	33 OHM, ARRAY, 8 PIN, 5%	Yageo	YC164-JR-0733R	4
RA223	33 OHM, ARRAY, 8 PIN, 5%	Yageo	YC164-JR-0733R	4
RA224	10K, ARRAY, 10 PIN, 8R, 5%	Yageo	YC158TJR-0710K	4
RA300	10K, ARRAY, 10 PIN, 8R, 5%	Yageo	YC158TJR-0710K	4
RA301	33 OHM, ARRAY, 8 PIN, 5%	Yageo	YC164-JR-0733R	4
RA302	33 OHM, ARRAY, 8 PIN, 5%	Yageo	YC164-JR-0733R	4
RA303	33 OHM, ARRAY, 8 PIN, 5%	Yageo	YC164-JR-0733R	4
RA304	33 OHM, ARRAY, 8 PIN, 5%	Yageo	YC164-JR-0733R	4
RA305	33 OHM, ARRAY, 8 PIN, 5%	Yageo	YC164-JR-0733R	4
RA306	33 OHM, ARRAY, 8 PIN, 5%	Yageo	YC164-JR-0733R	4
RA307	33 OHM, ARRAY, 8 PIN, 5%	Yageo	YC164-JR-0733R	4
RA308	33 OHM, ARRAY, 8 PIN, 5%	Yageo	YC164-JR-0733R	4
RA309	33 OHM, ARRAY, 8 PIN, 5%	Yageo	YC164-JR-0733R	4
RA310	33 OHM, ARRAY, 8 PIN, 5%	Yageo	YC164-JR-0733R	4
RA311	33 OHM, ARRAY, 8 PIN, 5%	Yageo	YC164-JR-0733R	4
RA312	33 OHM, ARRAY, 8 PIN, 5%	Yageo	YC164-JR-0733R	4
RA313	33 OHM, ARRAY, 8 PIN, 5%	Yageo	YC164-JR-0733R	4
RA314	10K, ARRAY, 10 PIN, 8R, 5%	Yageo	YC158TJR-0710K	4
RA315	10K, ARRAY, 10 PIN, 8R, 5%	Yageo	YC158TJR-0710K	4
RA316	33 OHM, ARRAY, 8 PIN, 5%	Yageo	YC164-JR-0733R	4
RA317	33 OHM, ARRAY, 8 PIN, 5%	Yageo	YC164-JR-0733R	4
RA318	33 OHM, ARRAY, 8 PIN, 5%	Yageo	YC164-JR-0733R	4
RA319	33 OHM, ARRAY, 8 PIN, 5%	Yageo	YC164-JR-0733R	4
RA400	10K, ARRAY, 10 PIN, 8R, 5%	Yageo	YC158TJR-0710K	4



# ELECTRICAL PART LIST

ESP-88 Digital Signal Processor (DSP) PCB Assembly

Resistor Arrays (continued)

Reference Designator	Description	Vendor	Vendor Part Number	Note
RA401	10K, ARRAY, 10 PIN, 8R, 5%	Yageo	YC158TJR-0710K	4
RA450	10K, ARRAY, 10 PIN, 8R, 5%	Yageo	YC158TJR-0710K	4
RA530	10K, ARRAY, 10 PIN, 8R, 5%	Yageo	YC158TJR-0710K	4
RA531	10K, ARRAY, 10 PIN, 8R, 5%	Yageo	YC158TJR-0710K	4
RA532	10K, ARRAY, 10 PIN, 8R, 5%	Yageo	YC158TJR-0710K	4
RA533	10K, ARRAY, 10 PIN, 8R, 5%	Yageo	YC158TJR-0710K	4

Capacitors

Reference Designator	Description	Vendor	Vendor Part Number	Note
C100	0.1uF, 0603, Y5V, 50V, 20%	Samsung	CL10F104ZBNC	4
C101	0.1uF, 0603, Y5V, 50V, 20%	Samsung	CL10F104ZBNC	4
C102	0.1uF, 0603, Y5V, 50V, 20%	Samsung	CL10F104ZBNC	4
C103	0.1uF, 0603, Y5V, 50V, 20%	Samsung	CL10F104ZBNC	4
C104	0.1uF, 0603, Y5V, 50V, 20%	Samsung	CL10F104ZBNC	4
C105	10uF, ELEC, 16V, 40C, 20%	NICHICON	UZT1C100MCR1GB	4
C106	0.1uF, 0603, Y5V, 50V, 20%	Samsung	CL10F104ZBNC	4
C107	0.1uF, 0603, Y5V, 50V, 20%	Samsung	CL10F104ZBNC	4
C108	0.1uF, 0603, Y5V, 50V, 20%	Samsung	CL10F104ZBNC	4
C109	0.1uF, 0603, Y5V, 50V, 20%	Samsung	CL10F104ZBNC	4
C110	0.1uF, 0603, Y5V, 50V, 20%	Samsung	CL10F104ZBNC	4
C111	10uF, ELEC, 16V, 40C, 20%	NICHICON	UZT1C100MCR1GB	4
C112	0.1uF, 0603, Y5V, 50V, 20%	Samsung	CL10F104ZBNC	4
C113	0.1uF, 0603, Y5V, 50V, 20%	Samsung	CL10F104ZBNC	4
C114	0.1uF, 0603, Y5V, 50V, 20%	Samsung	CL10F104ZBNC	4
C115	0.1uF, 0603, Y5V, 50V, 20%	Samsung	CL10F104ZBNC	4
C116	0.1uF, 0603, Y5V, 50V, 20%	Samsung	CL10F104ZBNC	4
C117	10uF, ELEC, 16V, 40C, 20%	NICHICON	UZT1C100MCR1GB	4
C118	0.1uF, 0603, Y5V, 50V, 20%	Samsung	CL10F104ZBNC	4
C119	0.1uF, 0603, Y5V, 50V, 20%	Samsung	CL10F104ZBNC	4
C120	0.1uF, 0603, Y5V, 50V, 20%	Samsung	CL10F104ZBNC	4
C121	0.1uF, 0603, Y5V, 50V, 20%	Samsung	CL10F104ZBNC	4
C122	0.1uF, 0603, Y5V, 50V, 20%	Samsung	CL10F104ZBNC	4
C123	10uF, ELEC, 16V, 40C, 20%	NICHICON	UZT1C100MCR1GB	4
C124	0.1uF, 0603, Y5V, 50V, 20%	Samsung	CL10F104ZBNC	4
C125	0.1uF, 0603, Y5V, 50V, 20%	Samsung	CL10F104ZBNC	4
C126	0.1uF, 0603, Y5V, 50V, 20%	Samsung	CL10F104ZBNC	4
C127	0.1uF, 0603, Y5V, 50V, 20%	Samsung	CL10F104ZBNC	4
C128	0.1uF, 0603, Y5V, 50V, 20%	Samsung	CL10F104ZBNC	4
C129	0.1uF, 0603, Y5V, 50V, 20%	Samsung	CL10F104ZBNC	4
C130	0.1uF, 0603, Y5V, 50V, 20%	Samsung	CL10F104ZBNC	4
C131	0.1uF, 0603, Y5V, 50V, 20%	Samsung	CL10F104ZBNC	4
C132	0.1uF, 0603, Y5V, 50V, 20%	Samsung	CL10F104ZBNC	4
C133	0.1uF, 0603, Y5V, 50V, 20%	Samsung	CL10F104ZBNC	4
C134	0.1uF, 0603, Y5V, 50V, 20%	Samsung	CL10F104ZBNC	4
C135	0.1uF, 0603, Y5V, 50V, 20%	Samsung	CL10F104ZBNC	4
C136	0.1uF, 0603, Y5V, 50V, 20%	Samsung	CL10F104ZBNC	4
C137	0.1uF, 0603, Y5V, 50V, 20%	Samsung	CL10F104ZBNC	4
C138	0.1uF, 0603, Y5V, 50V, 20%	Samsung	CL10F104ZBNC	4

# ELECTRICAL PART LIST

ESP-88 Digital Signal Processor (DSP) PCB Assembly

Capacitors (continued)

Reference Designator	Description	Vendor	Vendor Part Number	Note
C139	10uF, ELEC, 16V, 40C, 20%	NICHICON	UZT1C100MCR1GB	4
C140	0.1uF, 0603, Y5V, 50V, 20%	Samsung	CL10F104ZBNC	4
C141	0.1uF, 0603, Y5V, 50V, 20%	Samsung	CL10F104ZBNC	4
C142	0.1uF, 0603, Y5V, 50V, 20%	Samsung	CL10F104ZBNC	4
C143	0.1uF, 0603, Y5V, 50V, 20%	Samsung	CL10F104ZBNC	4
C144	0.1uF, 0603, Y5V, 50V, 20%	Samsung	CL10F104ZBNC	4
C145	0.1uF, 0603, Y5V, 50V, 20%	Samsung	CL10F104ZBNC	4
C146	0.1uF, 0603, Y5V, 50V, 20%	Samsung	CL10F104ZBNC	4
C147	0.1uF, 0603, Y5V, 50V, 20%	Samsung	CL10F104ZBNC	4
C148	10uF, ELEC, 16V, 40C, 20%	NICHICON	UZT1C100MCR1GB	4
C149	0.1uF, 0603, Y5V, 50V, 20%	Samsung	CL10F104ZBNC	4
C150	0.1uF, 0603, Y5V, 50V, 20%	Samsung	CL10F104ZBNC	4
C151	0.1uF, 0603, Y5V, 50V, 20%	Samsung	CL10F104ZBNC	4
C152	0.1uF, 0603, Y5V, 50V, 20%	Samsung	CL10F104ZBNC	4
C153	0.1uF, 0603, Y5V, 50V, 20%	Samsung	CL10F104ZBNC	4
C154	0.1uF, 0603, Y5V, 50V, 20%	Samsung	CL10F104ZBNC	4
C155	0.1uF, 0603, Y5V, 50V, 20%	Samsung	CL10F104ZBNC	4
C156	0.1uF, 0603, Y5V, 50V, 20%	Samsung	CL10F104ZBNC	4
C157	10uF, ELEC, 16V, 40C, 20%	NICHICON	UZT1C100MCR1GB	4
C158	10uF, ELEC, 16V, 40C, 20%	NICHICON	UZT1C100MCR1GB	4
C159	0.1uF, 0603, Y5V, 50V, 20%	Samsung	CL10F104ZBNC	4
C160	0.1uF, 0603, Y5V, 50V, 20%	Samsung	CL10F104ZBNC	4
C161	0.1uF, 0603, Y5V, 50V, 20%	Samsung	CL10F104ZBNC	4
C162	0.1uF, 0603, Y5V, 50V, 20%	Samsung	CL10F104ZBNC	4
C163	0.1uF, 0603, Y5V, 50V, 20%	Samsung	CL10F104ZBNC	4
C164	0.1uF, 0603, Y5V, 50V, 20%	Samsung	CL10F104ZBNC	4
C165	0.1uF, 0603, Y5V, 50V, 20%	Samsung	CL10F104ZBNC	4
C166	0.1uF, 0603, Y5V, 50V, 20%	Samsung	CL10F104ZBNC	4
C167	0.1uF, 0603, Y5V, 50V, 20%	Samsung	CL10F104ZBNC	4
C168	10uF, ELEC, 16V, 40C, 20%	NICHICON	UZT1C100MCR1GB	4
C169	47pF, 0603, 50V, NPO, 55C, 5%	Samsung	CL10C470JBNC	4
C170	47pF, 0603, 50V, NPO, 55C, 5%	Samsung	CL10C470JBNC	4
C171	47pF, 0603, 50V, NPO, 55C, 5%	Samsung	CL10C470JBNC	4
C172	0.1uF, 0603, Y5V, 50V, 20%	Samsung	CL10F104ZBNC	4
C173	0.1uF, 0603, Y5V, 50V, 20%	Samsung	CL10F104ZBNC	4
C174	0.1uF, 0603, Y5V, 50V, 20%	Samsung	CL10F104ZBNC	4
C175	0.1uF, 0603, Y5V, 50V, 20%	Samsung	CL10F104ZBNC	4
C176	47pF, 0603, 50V, NPO, 55C, 5%	Samsung	CL10C470JBNC	4
C200	10uF, ELEC, 16V, 40C, 20%	NICHICON	UZT1C100MCR1GB	4
C201	10uF, ELEC, 16V, 40C, 20%	NICHICON	UZT1C100MCR1GB	4
C202	0.1uF, 0603, Y5V, 50V, 20%	Samsung	CL10F104ZBNC	4
C203	10uF, ELEC, 16V, 40C, 20%	NICHICON	UZT1C100MCR1GB	4
C204	10uF, ELEC, 16V, 40C, 20%	NICHICON	UZT1C100MCR1GB	4
C205	0.1uF, 0603, Y5V, 50V, 20%	Samsung	CL10F104ZBNC	4
C206	0.1uF, 0603, Y5V, 50V, 20%	Samsung	CL10F104ZBNC	4
C207	0.1uF, 0603, Y5V, 50V, 20%	Samsung	CL10F104ZBNC	4
C208	0.1uF, 0603, Y5V, 50V, 20%	Samsung	CL10F104ZBNC	4
C209	0.1uF, 0603, Y5V, 50V, 20%	Samsung	CL10F104ZBNC	4
C210	0.1uF, 0603, Y5V, 50V, 20%	Samsung	CL10F104ZBNC	4

# ELECTRICAL PART LIST

ESP-88 Digital Signal Processor (DSP) PCB Assembly

Capacitors (continued)

Reference Designator	Description	Vendor	Vendor Part Number	Note
C211	0.1uF, 0603, Y5V, 50V, 20%	Samsung	CL10F104ZBNC	4
C212	0.1uF, 0603, Y5V, 50V, 20%	Samsung	CL10F104ZBNC	4
C213	0.1uF, 0603, Y5V, 50V, 20%	Samsung	CL10F104ZBNC	4
C214	0.1uF, 0603, Y5V, 50V, 20%	Samsung	CL10F104ZBNC	4
C215	0.1uF, 0603, Y5V, 50V, 20%	Samsung	CL10F104ZBNC	4
C216	0.1uF, 0603, Y5V, 50V, 20%	Samsung	CL10F104ZBNC	4
C217	0.1uF, 0603, Y5V, 50V, 20%	Samsung	CL10F104ZBNC	4
C218	0.1uF, 0603, Y5V, 50V, 20%	Samsung	CL10F104ZBNC	4
C219	0.1uF, 0603, Y5V, 50V, 20%	Samsung	CL10F104ZBNC	4
C220	0.1uF, 0603, Y5V, 50V, 20%	Samsung	CL10F104ZBNC	4
C221	0.1uF, 0603, Y5V, 50V, 20%	Samsung	CL10F104ZBNC	4
C222	0.1uF, 0603, Y5V, 50V, 20%	Samsung	CL10F104ZBNC	4
C223	0.1uF, 0603, Y5V, 50V, 20%	Samsung	CL10F104ZBNC	4
C224	0.1uF, 0603, Y5V, 50V, 20%	Samsung	CL10F104ZBNC	4
C225	0.1uF, 0603, Y5V, 50V, 20%	Samsung	CL10F104ZBNC	4
C226	0.1uF, 0603, Y5V, 50V, 20%	Samsung	CL10F104ZBNC	4
C227	0.1uF, 0603, Y5V, 50V, 20%	Samsung	CL10F104ZBNC	4
C228	0.1uF, 0603, Y5V, 50V, 20%	Samsung	CL10F104ZBNC	4
C229	0.1uF, 0603, Y5V, 50V, 20%	Samsung	CL10F104ZBNC	4
C230	0.1uF, 0603, Y5V, 50V, 20%	Samsung	CL10F104ZBNC	4
C231	0.1uF, 0603, Y5V, 50V, 20%	Samsung	CL10F104ZBNC	4
C232	0.1uF, 0603, Y5V, 50V, 20%	Samsung	CL10F104ZBNC	4
C233	0.1uF, 0603, Y5V, 50V, 20%	Samsung	CL10F104ZBNC	4
C234	0.1uF, 0603, Y5V, 50V, 20%	Samsung	CL10F104ZBNC	4
C235	0.1uF, 0603, Y5V, 50V, 20%	Samsung	CL10F104ZBNC	4
C236	47pF, 0603, 50V, NPO, 55C, 5%	Samsung	CL10C470JBNC	4
C300	22pF, 0603, 50V, NPO, 55C, 5%	Samsung	CL10C220JBNC	4
C301	0.1uF, 0603, Y5V, 50V, 20%	Samsung	CL10F104ZBNC	4
C302	0.1uF, 0603, Y5V, 50V, 20%	Samsung	CL10F104ZBNC	4
C303	0.1uF, 0603, Y5V, 50V, 20%	Samsung	CL10F104ZBNC	4
C304	0.1uF, 0603, Y5V, 50V, 20%	Samsung	CL10F104ZBNC	4
C305	0.1uF, 0603, Y5V, 50V, 20%	Samsung	CL10F104ZBNC	4
C306	0.1uF, 0603, Y5V, 50V, 20%	Samsung	CL10F104ZBNC	4
C307	0.1uF, 0603, Y5V, 50V, 20%	Samsung	CL10F104ZBNC	4
C308	0.1uF, 0603, Y5V, 50V, 20%	Samsung	CL10F104ZBNC	4
C309	0.1uF, 0603, Y5V, 50V, 20%	Samsung	CL10F104ZBNC	4
C310	22pF, 0603, 50V, NPO, 55C, 5%	Samsung	CL10C220JBNC	4
C311	22pF, 0603, 50V, NPO, 55C, 5%	Samsung	CL10C220JBNC	4
C312	22pF, 0603, 50V, NPO, 55C, 5%	Samsung	CL10C220JBNC	4
C313	0.1uF, 0603, Y5V, 50V, 20%	Samsung	CL10F104ZBNC	4
C314	0.1uF, 0603, Y5V, 50V, 20%	Samsung	CL10F104ZBNC	4
C315	10uF, ELEC, 16V, 40C, 20%	NICHICON	UZT1C100MCR1GB	4
C316	10uF, ELEC, 16V, 40C, 20%	NICHICON	UZT1C100MCR1GB	4
C317	0.1uF, 0603, Y5V, 50V, 20%	Samsung	CL10F104ZBNC	4
C318	0.1uF, 0603, Y5V, 50V, 20%	Samsung	CL10F104ZBNC	4
C319	0.1uF, 0603, Y5V, 50V, 20%	Samsung	CL10F104ZBNC	4
C320	0.1uF, 0603, Y5V, 50V, 20%	Samsung	CL10F104ZBNC	4
C321	10uF, ELEC, 16V, 40C, 20%	NICHICON	UZT1C100MCR1GB	4
C322	0.1uF, 0603, Y5V, 50V, 20%	Samsung	CL10F104ZBNC	4

# ELECTRICAL PART LIST

ESP-88 Digital Signal Processor (DSP) PCB Assembly

Capacitors (continued)

Reference Designator	Description	Vendor	Vendor Part Number	Note
C323	0.1uF, 0603, Y5V, 50V, 20%	Samsung	CL10F104ZBNC	4
C324	0.1uF, 0603, Y5V, 50V, 20%	Samsung	CL10F104ZBNC	4
C325	0.1uF, 0603, Y5V, 50V, 20%	Samsung	CL10F104ZBNC	4
C326	0.1uF, 0603, Y5V, 50V, 20%	Samsung	CL10F104ZBNC	4
C327	0.1uF, 0603, Y5V, 50V, 20%	Samsung	CL10F104ZBNC	4
C328	0.1uF, 0603, Y5V, 50V, 20%	Samsung	CL10F104ZBNC	4
C329	0.1uF, 0603, Y5V, 50V, 20%	Samsung	CL10F104ZBNC	4
C330	0.1uF, 0603, Y5V, 50V, 20%	Samsung	CL10F104ZBNC	4
C331	10uF, ELEC, 16V, 40C, 20%	NICHICON	UZT1C100MCR1GB	4
C332	0.1uF, 0603, Y5V, 50V, 20%	Samsung	CL10F104ZBNC	4
C333	0.047uF, 0603, X7R, 50V, 10%	Samsung	CL10B471KBNC	4
C334	0.1uF, 0603, Y5V, 50V, 20%	Samsung	CL10F104ZBNC	4
C335	0.047uF, 0603, X7R, 50V, 10%	Samsung	CL10B471KBNC	4
C336	10uF, ELEC, 16V, 40C, 20%	NICHICON	UZT1C100MCR1GB	4
C337	47pF, 0603, 50V, NPO, 55C, 5%	Samsung	CL10C470JBNC	4
C338	47pF, 0603, 50V, NPO, 55C, 5%	Samsung	CL10C470JBNC	4
C339	47pF, 0603, 50V, NPO, 55C, 5%	Samsung	CL10C470JBNC	4
C340	47pF, 0603, 50V, NPO, 55C, 5%	Samsung	CL10C470JBNC	4
C341	47pF, 0603, 50V, NPO, 55C, 5%	Samsung	CL10C470JBNC	4
C342	47pF, 0603, 50V, NPO, 55C, 5%	Samsung	CL10C470JBNC	4
C343	47pF, 0603, 50V, NPO, 55C, 5%	Samsung	CL10C470JBNC	4
C345	47pF, 0603, 50V, NPO, 55C, 5%	Samsung	CL10C470JBNC	4
C346	47pF, 0603, 50V, NPO, 55C, 5%	Samsung	CL10C470JBNC	4
C348	47pF, 0603, 50V, NPO, 55C, 5%	Samsung	CL10C470JBNC	4
C349	47pF, 0603, 50V, NPO, 55C, 5%	Samsung	CL10C470JBNC	4
C350	47pF, 0603, 50V, NPO, 55C, 5%	Samsung	CL10C470JBNC	4
C351	47pF, 0603, 50V, NPO, 55C, 5%	Samsung	CL10C470JBNC	4
C352	47pF, 0603, 50V, NPO, 55C, 5%	Samsung	CL10C470JBNC	4
C353	47pF, 0603, 50V, NPO, 55C, 5%	Samsung	CL10C470JBNC	4
C354	47pF, 0603, 50V, NPO, 55C, 5%	Samsung	CL10C470JBNC	4
C400	0.047uF, 0603, X7R, 50V, 10%	Samsung	CL10B103KBNC	4
C402	0.047uF, 0603, X7R, 50V, 10%	Samsung	CL10B561KBNC	4
C404	0.1uF, 0603, Y5V, 50V, 20%	Samsung	CL10F104ZBNC	4
C405	0.1uF, 0603, Y5V, 50V, 20%	Samsung	CL10F104ZBNC	4
C406	0.1uF, 0603, Y5V, 50V, 20%	Samsung	CL10F104ZBNC	4
C407	0.1uF, 0603, Y5V, 50V, 20%	Samsung	CL10F104ZBNC	4
C408	0.1uF, 0603, Y5V, 50V, 20%	Samsung	CL10F104ZBNC	4
C409	0.1uF, 0603, Y5V, 50V, 20%	Samsung	CL10F104ZBNC	4
C410	0.1uF, 0603, Y5V, 50V, 20%	Samsung	CL10F104ZBNC	4
C411	0.1uF, 0603, Y5V, 50V, 20%	Samsung	CL10F104ZBNC	4
C412	0.1uF, 0603, Y5V, 50V, 20%	Samsung	CL10F104ZBNC	4
C413	0.1uF, 0603, Y5V, 50V, 20%	Samsung	CL10F104ZBNC	4
C414	0.1uF, 0603, Y5V, 50V, 20%	Samsung	CL10F104ZBNC	4
C450	0.1uF, 0603, Y5V, 50V, 20%	Samsung	CL10F104ZBNC	4
C451	0.1uF, 0603, Y5V, 50V, 20%	Samsung	CL10F104ZBNC	4
C452	0.1uF, 0603, Y5V, 50V, 20%	Samsung	CL10F104ZBNC	4
C453	0.1uF, 0603, Y5V, 50V, 20%	Samsung	CL10F104ZBNC	4
C454	0.1uF, 0603, Y5V, 50V, 20%	Samsung	CL10F104ZBNC	4
C455	0.1uF, 0603, Y5V, 50V, 20%	Samsung	CL10F104ZBNC	4



# ELECTRICAL PART LIST

ESP-88 Digital Signal Processor (DSP) PCB Assembly

Capacitors (continued)

Reference Designator	Description	Vendor	Vendor Part Number	Note
C456	0.047uF, 0603, X7R, 50V, 10%	Samsung	CL10B471KBNC	4
C457	0.1uF, 0603, Y5V, 50V, 20%	Samsung	CL10F104ZBNC	4
C458	0.1uF, 0603, Y5V, 50V, 20%	Samsung	CL10F104ZBNC	4
C459	0.1uF, 0603, Y5V, 50V, 20%	Samsung	CL10F104ZBNC	4
C460	0.1uF, 0603, Y5V, 50V, 20%	Samsung	CL10F104ZBNC	4
C461	0.1uF, 0603, Y5V, 50V, 20%	Samsung	CL10F104ZBNC	4
C462	0.1uF, 0603, Y5V, 50V, 20%	Samsung	CL10F104ZBNC	4
C463	0.1uF, 0603, Y5V, 50V, 20%	Samsung	CL10F104ZBNC	4
C464	0.1uF, 0603, Y5V, 50V, 20%	Samsung	CL10F104ZBNC	4
C465	0.1uF, 0603, Y5V, 50V, 20%	Samsung	CL10F104ZBNC	4
C466	0.1uF, 0603, Y5V, 50V, 20%	Samsung	CL10F104ZBNC	4
C467	0.1uF, 0603, Y5V, 50V, 20%	Samsung	CL10F104ZBNC	4
C468	10uF, ELEC, 16V, 40C, 20%	NICHICON	UZT1C100MCR1GB	4
C469	0.1uF, 0603, Y5V, 50V, 20%	Samsung	CL10F104ZBNC	4
C470	0.1uF, 0603, Y5V, 50V, 20%	Samsung	CL10F104ZBNC	4
C471	0.1uF, 0603, Y5V, 50V, 20%	Samsung	CL10F104ZBNC	4
C472	0.1uF, 0603, Y5V, 50V, 20%	Samsung	CL10F104ZBNC	4
C473	0.1uF, 0603, Y5V, 50V, 20%	Samsung	CL10F104ZBNC	4
C474	0.1uF, 0603, Y5V, 50V, 20%	Samsung	CL10F104ZBNC	4
C478	10uF, ELEC, 16V, 40C, 20%	NICHICON	UZT1C100MCR1GB	4
C479	10uF, ELEC, 16V, 40C, 20%	NICHICON	UZT1C100MCR1GB	4
C480	0.1uF, 0603, Y5V, 50V, 20%	Samsung	CL10F104ZBNC	4
C481	0.1uF, 0603, Y5V, 50V, 20%	Samsung	CL10F104ZBNC	4
C482	10uF, ELEC, 16V, 40C, 20%	NICHICON	UZT1C100MCR1GB	4
C483	10uF, ELEC, 16V, 40C, 20%	NICHICON	UZT1C100MCR1GB	4
C484	0.1uF, 0603, Y5V, 50V, 20%	Samsung	CL10F104ZBNC	4
C485	0.1uF, 0603, Y5V, 50V, 20%	Samsung	CL10F104ZBNC	4
C486	10uF, ELEC, 16V, 40C, 20%	NICHICON	UZT1C100MCR1GB	4
C487	10uF, ELEC, 16V, 40C, 20%	NICHICON	UZT1C100MCR1GB	4
C488	0.1uF, 0603, Y5V, 50V, 20%	Samsung	CL10F104ZBNC	4
C489	0.1uF, 0603, Y5V, 50V, 20%	Samsung	CL10F104ZBNC	4
C490	10uF, ELEC, 16V, 40C, 20%	NICHICON	UZT1C100MCR1GB	4
C492	0.1uF, 0603, Y5V, 50V, 20%	Samsung	CL10F104ZBNC	4
C493	100uF, ELEC, 16V, 40C, 20%	NICHICON	UWX1C101MCR1GB	4
C493	100uF, ELEC, 16V, 55C, 20%	NICHICON	UWT1C101MCR1GB	4
C494	0.1uF, 0603, Y5V, 50V, 20%	Samsung	CL10F104ZBNC	4
C495	0.047uF, 0603, X7R, 50V, 10%	Samsung	CL10B473KBNC	4
C496	0.047uF, 0603, X7R, 50V, 10%	Samsung	CL10B102KBNC	4
C497	470uF, TANT, 4V, 55C, 20%	NICHICON	F930G477MNC	4
C498	100uF, ELEC, 16V, 40C, 20%	NICHICON	UWX1C101MCR1GB	4
C498	100uF, ELEC, 16V, 55C, 20%	NICHICON	UWT1C101MCR1GB	4
C499	0.1uF, 0603, Y5V, 50V, 20%	Samsung	CL10F104ZBNC	4
C500	0.1uF, 0603, Y5V, 50V, 20%	Samsung	CL10F104ZBNC	4
C501	0.1uF, 0603, Y5V, 50V, 20%	Samsung	CL10F104ZBNC	4
C502	0.1uF, 0603, Y5V, 50V, 20%	Samsung	CL10F104ZBNC	4
C503	0.1uF, 0603, Y5V, 50V, 20%	Samsung	CL10F104ZBNC	4
C504	0.1uF, 0603, Y5V, 50V, 20%	Samsung	CL10F104ZBNC	4
C505	0.1uF, 0603, Y5V, 50V, 20%	Samsung	CL10F104ZBNC	4
C506	0.1uF, 0603, Y5V, 50V, 20%	Samsung	CL10F104ZBNC	4

# ELECTRICAL PART LIST

ESP-88 Digital Signal Processor (DSP) PCB Assembly

Capacitors (continued)

Reference Designator	Description	Vendor	Vendor Part Number	Note
C507	47pF, 0603, 50V, NPO, 55C, 5%	Samsung	CL10C470JBNC	4
C531	47pF, 0603, 50V, NPO, 55C, 5%	Samsung	CL10C470JBNC	4
C532	47pF, 0603, 50V, NPO, 55C, 5%	Samsung	CL10C470JBNC	4
C533	47pF, 0603, 50V, NPO, 55C, 5%	Samsung	CL10C470JBNC	4
C534	47pF, 0603, 50V, NPO, 55C, 5%	Samsung	CL10C470JBNC	4
C535	0.1uF, 0603, Y5V, 50V, 20%	Samsung	CL10F104ZBNC	4
C536	0.1uF, 0603, Y5V, 50V, 20%	Samsung	CL10F104ZBNC	4
C537	0.1uF, 0603, Y5V, 50V, 20%	Samsung	CL10F104ZBNC	4
C538	0.1uF, 0603, Y5V, 50V, 20%	Samsung	CL10F104ZBNC	4
C539	0.1uF, 0603, Y5V, 50V, 20%	Samsung	CL10F104ZBNC	4
C540	0.1uF, 0603, Y5V, 50V, 20%	Samsung	CL10F104ZBNC	4

Inductors

Reference Designator	Description	Vendor	Vendor Part Number	Note
L100	EMI FILTER, 50V, 300mA, 20%	Murata	NFM21CC223R1H3D	4
L300	EMI FILTER, 50V, 300mA, 20%	Murata	NFM21CC223R1H3D	4
L301	EMI FILTER, 50V, 300mA, 20%	Murata	NFM21CC223R1H3D	4
L302	EMI FILTER, 50V, 300mA, 20%	Murata	NFM21CC223R1H3D	4
L400	EMI FILTER, 50V, 300mA, 20%	Murata	NFM21CC223R1H3D	4
L401	XFMR, 10BASE-T, SOIC-16	E&E	821-M0542	4
L402	EMI FILTER, 50V, 300mA, 20%	Murata	NFM21CC102R1H3D	4
L403	EMI FILTER, 50V, 300mA, 20%	Murata	NFM21CC102R1H3D	4
L404	EMI FILTER, 50V, 300mA, 20%	Murata	NFM21CC102R1H3D	4
L405	EMI FILTER, 50V, 300mA, 20%	Murata	NFM21CC102R1H3D	4
L450	EMI FILTER, 50V, 300mA, 20%	Murata	NFM21CC102R1H3D	4
L451	EMI FILTER, 50V, 300mA, 20%	Murata	NFM21CC102R1H3D	4
L452	EMI FILTER, 50V, 300mA, 20%	Murata	NFM21CC102R1H3D	4
L453	EMI FILTER, 50V, 300mA, 20%	Murata	NFM21CC102R1H3D	4
L454	EMI FILTER, 50V, 300mA, 20%	Murata	NFM21CC102R1H3D	4
L455	EMI FILTER, 50V, 300mA, 20%	Murata	NFM21CC102R1H3D	4
L456	POWER IND, 5.2uH, 30%	SUMIDA	CDRH104R-5R2NC	4
L457	EMI FILTER, 50V, 300mA, 20%	Murata	NFM21CC223R1H3D	4
L458	EMI FILTER, 50V, 300mA, 20%	Murata	NFM21CC223R1H3D	4

Diodes

Reference Designator	Description	Vendor	Vendor Part Number	Note
D450	SCHOTTKY, SC59	Toshiba	1SS396	4
D451	SCHOTTKY, SC59	Toshiba	1SS396	4
D453	RECT, 400V, 1A, SOD-106	ROHM	1SR154-400	4
D454	RECT, 400V, 1A, SOD-106	ROHM	1SR154-400	4
D455	RECT, 400V, 1A, SOD-106	ROHM	1SR154-400	4
D456	SCHOTTKY, SC59	Toshiba	1SS396	4
D457	SCHOTTKY, SC59	Toshiba	1SS396	4
D458	SCHOTTKY, SC59	Toshiba	1SS396	4
D459	SCHOTTKY, SC59	Toshiba	1SS396	4
D461	RECT, 400V, 1A, SOD-106	ROHM	1SR154-400	4
D462	RECT, 400V, 1A, SOD-106	ROHM	1SR154-400	4
D463	RECT, 400V, 1A, SOD-106	ROHM	1SR154-400	4



# ELECTRICAL PART LIST

ESP-88 Digital Signal Processor (DSP) PCB Assembly

## Transistors

Reference Designator	Description	Vendor	Vendor Part Number	Note
Q450	PNP, 50V, 100Ma, SOT-23	KEC	KRA102S	4
Q451	PNP, 50V, 100Ma, SOT-23	KEC	KRA102S	4
Q452	PNP, 50V, 100Ma, SOT-23	KEC	KRA102S	4
Q453	PNP, 50V, 100Ma, SOT-23	KEC	KRA102S	4
Q454	PNP, 50V, 100Ma, SOT-23	KEC	KRA102S	4
Q455	PNP, 50V, 100Ma, SOT-23	KEC	KRA102S	4
Q456	PNP, 50V, 100Ma, SOT-23	KEC	KRA102S	4
Q457	PNP, 50V, 100Ma, SOT-23	KEC	KRA102S	4
Q458	NPN, 50V, 100mA, SOT-23	KEC	KRC102S	4

## Integrated Circuits

Reference Designator	Description	Vendor	Vendor Part Number	Note
M100	SDRAM, TSOP-54	ELPIDA	EDS1216AATA-75	4
M101	DSP, QFP-208	TI	TMS320C6713BPYP	4
M200	PROG GATE ARRAY, QFP-208	XILINX	XC2S150E6PQ208C	4
M201	OCTAL BUFFER DR, TSSOP20	ONsemi	MC74VHC541DT	4
M202	OCTAL BUFFER DR, TSSOP20	ONsemi	MC74VHC541DT	4
M300	MICROPROCESSOR, QFP-176	Renases	HD6417706F133	4
M301	SDRAM, TSOP-54	ELPIDA	EDS1216AATA-75	4
M302	FLASH MEMORY, TSOP-48	SPANSION	S29GL064M90TAIR	4
M400	HEX INVERTER, TSSOP-14	ONSEMI	MC74VHC04DT	4
M401	ETHER LAN CONT, TQFP-100	Cirrus	CS8900A-CQ3	4
M450	TRANSCEIVER, SOIC-16	Harris/Intersil	HIN202ECB	4
M452	OCTAL BUFFER DR, TSSOP20	ONsemi	MC74VHC541DT	4
M453	VOLT DET, SOT-23-5	SEIKO	S-80947CNMC-G9H-T2	4
M454	VOLT DET, TSOP-5	ONSEMI	NCP303LSN11T1	4
M455	VOLT DET, SOT-23-5	SEIKO	S-80917CNMC-G8M-T2	4
M456	VOLT DET, SOT-23-5	SEIKO	S-80917CNMC-G8M-T2	4
M457	VOLT DET, Vd=3.0V	SEIKO	S-80930CNMC-G80-T2	4
M458	VOLT DET, SOT-23-5	SEIKO	S-80940CNMC-G9A-T2	4
M460	REG, 3.3V, 1A, TO-252	NEC	UPC2933T	4
M461	REG, SOT-223, TI	NEC	LM317DCY	4
M462	REG, SOT-223, TI	NEC	LM317DCY	4
M463	PWM SWITCHER	TI	TPS54312PWP	4

## Miscellaneous

Reference Designator	Description	Vendor	Vendor Part Number	Note
CN452	CONN, SMT, 1.0MM, 100 PIN	KEL	87BFN-100R	4
CN530	CONN, SMT, 100P	Molex	52584-1079	4
X200	50.000MHz, 100ppm, 50pF	KDS	DSO531SVL 50MHz	4
X201	24.576MHz, 100ppm, 50pF	KDS	DSO531SVL 24.576MHz	4

# ELECTRICAL PART LIST

ESP-88 General Input/Output (GIO) PCB Assembly

Resistors

Reference Designator	Description	Vendor	Vendor Part Number	Note
R100	100 OHM, 0603, 1/10W, 1%	Yageo	RC0603FR-07100R	4
R101	100 OHM, 0603, 1/10W, 1%	Yageo	RC0603FR-07100R	4
R102	100 OHM, 0603, 1/10W, 1%	Yageo	RC0603FR-07100R	4
R103	100 OHM, 0603, 1/10W, 1%	Yageo	RC0603FR-07100R	4
R104	100 OHM, 0603, 1/10W, 1%	Yageo	RC0603FR-07100R	4
R105	100 OHM, 0603, 1/10W, 1%	Yageo	RC0603FR-07100R	4
R106	100 OHM, 0603, 1/10W, 1%	Yageo	RC0603FR-07100R	4
R107	100 OHM, 0603, 1/10W, 1%	Yageo	RC0603FR-07100R	4
R108	5.1K, 0603, 1/10W, 1%	Yageo	RC0603FR-075K1	4
R109	5.1K, 0603, 1/10W, 1%	Yageo	RC0603FR-075K1	4
R110	5.1K, 0603, 1/10W, 1%	Yageo	RC0603FR-075K1	4
R111	5.1K, 0603, 1/10W, 1%	Yageo	RC0603FR-075K1	4
R112	5.1K, 0603, 1/10W, 1%	Yageo	RC0603FR-075K1	4
R113	5.1K, 0603, 1/10W, 1%	Yageo	RC0603FR-075K1	4
R114	5.1K, 0603, 1/10W, 1%	Yageo	RC0603FR-075K1	4
R115	5.1K, 0603, 1/10W, 1%	Yageo	RC0603FR-075K1	4
R116	10K, 0603, 1/10W, 1%	Yageo	RC0603FR-0710K	4
R117	10K, 0603, 1/10W, 1%	Yageo	RC0603FR-0710K	4
R118	10K, 0603, 1/10W, 1%	Yageo	RC0603FR-0710K	4
R119	10K, 0603, 1/10W, 1%	Yageo	RC0603FR-0710K	4
R120	10K, 0603, 1/10W, 1%	Yageo	RC0603FR-0710K	4
R121	10K, 0603, 1/10W, 1%	Yageo	RC0603FR-0710K	4
R122	10K, 0603, 1/10W, 1%	Yageo	RC0603FR-0710K	4
R123	10K, 0603, 1/10W, 1%	Yageo	RC0603FR-0710K	4
R125	10K, 0603, 1/10W, 1%	Yageo	RC0603FR-0710K	4
R126	10K, 0603, 1/10W, 1%	Yageo	RC0603FR-0710K	4
R129	0 OHM, 0603, 1/10W, 5%	Yageo	RC0603JR-07R00	4
R130	0 OHM, 0603, 1/10W, 5%	Yageo	RC0603JR-07R00	4
R132	10K, 0603, 1/10W, 1%	Yageo	RC0603FR-0710K	4
R133	10K, 0603, 1/10W, 1%	Yageo	RC0603FR-0710K	4
R134	10K, 0603, 1/10W, 1%	Yageo	RC0603FR-0710K	4
R135	100 OHM, 0603, 1/10W, 1%	Yageo	RC0603FR-07100R	4
R136	100 OHM, 0603, 1/10W, 1%	Yageo	RC0603FR-07100R	4
R137	100 OHM, 0603, 1/10W, 1%	Yageo	RC0603FR-07100R	4
R138	100 OHM, 0603, 1/10W, 1%	Yageo	RC0603FR-07100R	4
R139	100 OHM, 0603, 1/10W, 1%	Yageo	RC0603FR-07100R	4
R140	100 OHM, 0603, 1/10W, 1%	Yageo	RC0603FR-07100R	4
R141	100 OHM, 0603, 1/10W, 1%	Yageo	RC0603FR-07100R	4
R142	100 OHM, 0603, 1/10W, 1%	Yageo	RC0603FR-07100R	4
R144	0 OHM, 0603, 1/10W, 5%	Yageo	RC0603JR-07R00	4
R145	330 OHM, 0603, 1/10W, 1%	Yageo	RC0603FR-07330R	4
R146	330 OHM, 0603, 1/10W, 1%	Yageo	RC0603FR-07330R	4

# ELECTRICAL PART LIST

ESP-88 General Input/Output (GIO) PCB Assembly

Capacitors

Reference Designator	Description	Vendor	Vendor Part Number	Note
C100	10uF, 16V, 40C, 20%	NICHICON	UZH1C100MCR1GB	4
C101	0.01uF, 0603, X7R, 50V, 55C, 10%	Samsung	CL10B103KBNC	4
C102	0.01uF, 0603, X7R, 50V, 55C, 10%	Samsung	CL10B103KBNC	4
C103	0.01uF, 0603, X7R, 50V, 55C, 10%	Samsung	CL10B103KBNC	4
C104	0.01uF, 0603, X7R, 50V, 55C, 10%	Samsung	CL10B103KBNC	4
C105	0.01uF, 0603, X7R, 50V, 55C, 10%	Samsung	CL10B103KBNC	4
C106	0.01uF, 0603, X7R, 50V, 55C, 10%	Samsung	CL10B103KBNC	4
C107	0.01uF, 0603, X7R, 50V, 55C, 10%	Samsung	CL10B103KBNC	4
C108	0.01uF, 0603, X7R, 50V, 55C, 10%	Samsung	CL10B103KBNC	4
C109	0.1uF, 0603, Y5V, 50V, -30C, 20%	Samsung	CL10F104ZBNC	4
C110	0.1uF, 0603, Y5V, 50V, -30C, 20%	Samsung	CL10F104ZBNC	4
C111	10uF, 16V, 40C, 20%	NICHICON	UZH1C100MCR1GB	4
C112	0.1uF, 0603, Y5V, 50V, -30C, 20%	Samsung	CL10F104ZBNC	4
C113	0.1uF, 0603, Y5V, 50V, -30C, 20%	Samsung	CL10F104ZBNC	4
C114	10uF, 16V, 40C, 20%	NICHICON	UZH1C100MCR1GB	4
C115	0.1uF, 0603, Y5V, 50V, -30C, 20%	Samsung	CL10F104ZBNC	4
C116	12pF, 0603, 50V, 55C, NPO, 5%	Samsung	CL10C120JBNC	4
C117	12pF, 0603, 50V, 55C, NPO, 5%	Samsung	CL10C120JBNC	4
C118	0.1uF, 0603, Y5V, 50V, -30C, 20%	Samsung	CL10F104ZBNC	4
C119	0.1uF, 0603, Y5V, 50V, -30C, 20%	Samsung	CL10F104ZBNC	4
C120	47uF, 16V, 40C, 20%	NICHICON	UZH1C470MCR1GB	4
C121	0.1uF, 0603, Y5V, 50V, -30C, 20%	Samsung	CL10F104ZBNC	4
C122	0.1uF, 0603, Y5V, 50V, -30C, 20%	Samsung	CL10F104ZBNC	4
C123	0.1uF, 0603, Y5V, 50V, -30C, 20%	Samsung	CL10F104ZBNC	4
C124	0.1uF, 0603, Y5V, 50V, -30C, 20%	Samsung	CL10F104ZBNC	4
C125	0.1uF, 0603, Y5V, 50V, -30C, 20%	Samsung	CL10F104ZBNC	4
C126	0.1uF, 0603, Y5V, 50V, -30C, 20%	Samsung	CL10F104ZBNC	4
C127	0.1uF, 0603, Y5V, 50V, -30C, 20%	Samsung	CL10F104ZBNC	4
C128	0.1uF, 0603, Y5V, 50V, -30C, 20%	Samsung	CL10F104ZBNC	4
C129	0.1uF, 0603, Y5V, 50V, -30C, 20%	Samsung	CL10F104ZBNC	4
C130	0.1uF, 0603, Y5V, 50V, -30C, 20%	Samsung	CL10F104ZBNC	4
C131	47pF, 0603, 50V, 55C, NPO, 5%	Samsung	CL10C470JBNC	4
C132	47pF, 0603, 50V, 55C, NPO, 5%	Samsung	CL10C470JBNC	4
C403	1000pF, CER, Y5P, 2KV, 55C, 10%	Panasonic	ECKD3D102KBP	4

# ELECTRICAL PART LIST

ESP-88 General Input/Output (GIO) PCB Assembly

## Inductors

Reference Designator	Description	Vendor	Vendor Part Number	Note
L100	EMI FILTER, SMD 300mA, 20%	Murata	NFM21CC223R1H3D	4
L101	EMI FILTER, SMD 300mA, 20%	Murata	NFM21CC223R1H3D	4
L102	EMI FILTER, SMD 300mA, 20%	Murata	NFM21CC223R1H3D	4
L103	EMI FILTER, SMD 300mA, 20%	Murata	NFM21CC223R1H3D	4
L104	EMI FILTER, SMD 300mA, 20%	Murata	NFM21CC223R1H3D	4
L105	EMI FILTER, SMD 300mA, 20%	Murata	NFM21CC223R1H3D	4
L106	EMI FILTER, SMD 300mA, 20%	Murata	NFM21CC223R1H3D	4
L107	EMI FILTER, SMD 300mA, 20%	Murata	NFM21CC223R1H3D	4
L108	EMI FILTER, SMD 300mA, 20%	Murata	NFM21CC223R1H3D	4
L109	EMI FILTER, SMD 300mA, 20%	Murata	NFM21CC223R1H3D	4
L110	EMI FILTER, SMD 300mA, 20%	Murata	NFM21CC223R1H3D	4
L111	EMI FILTER, SMD 300mA, 20%	Murata	NFM21CC223R1H3D	4
L112	EMI FILTER, SMD 300mA, 20%	Murata	NFM21CC223R1H3D	4
L113	EMI FILTER, SMD 300mA, 20%	Murata	NFM21CC223R1H3D	4
L114	EMI FILTER, SMD 300mA, 20%	Murata	NFM21CC223R1H3D	4
L115	EMI FILTER, SMD 300mA, 20%	Murata	NFM21CC223R1H3D	4
L116	EMI FILTER, SMD 300mA, 20%	Murata	NFM21CC223R1H3D	4
L117	EMI FILTER, SMD 300mA, 20%	Murata	NFM21CC223R1H3D	4
L118	EMI FILTER, SMD 300mA, 20%	Murata	NFM21CC223R1H3D	4

## Diodes

Reference Designator	Description	Vendor	Vendor Part Number	Note
D108	RECTIFIER, 400V, 1A, SOD-106	ROHM	1SR154-400	4
D464	LED, RIGHT ANGLE, RED/GREEN	KINGBRIGHT	W42WUM/EGW	4
D465	LED, RIGHT ANGLE, RED/GREEN	KINGBRIGHT	W42WUM/EGW	4
D466	LED, RIGHT ANGLE, RED/GREEN	KINGBRIGHT	W42WUM/EGW	4
D467	LED, RIGHT ANGLE, RED/GREEN	KINGBRIGHT	W42WUM/EGW	4

## Transistors

Reference Designator	Description	Vendor	Vendor Part Number	Note
Q100	NPN, 50V, 100mA, SOT-23	KEC	KRC102S	4
Q101	NPN, 50V, 100mA, SOT-23	KEC	KRC102S	4
Q102	NPN, 50V, 100mA, SOT-23	KEC	KRC102S	4
Q103	NPN, 50V, 100mA, SOT-23	KEC	KRC102S	4
Q104	NPN, 50V, 100mA, SOT-23	KEC	KRC102S	4
Q105	NPN, 50V, 100mA, SOT-23	KEC	KRC102S	4
Q106	NPN, 50V, 100mA, SOT-23	KEC	KRC102S	4
Q107	NPN, 50V, 100mA, SOT-23	KEC	KRC102S	4
Q109	NPN, 50V, 100mA, SOT-23	KEC	KRC102S	4
Q110	NPN, 50V, 100mA, SOT-23	KEC	KRC102S	4
Q111	NPN, 50V, 100mA, SOT-23	KEC	KRC102S	4
Q112	NPN, 50V, 100mA, SOT-23	KEC	KRC102S	4
Q113	NPN, 50V, 100mA, SOT-23	KEC	KRC102S	4

# ELECTRICAL PART LIST

ESP-88 General Input/Output (GIO) PCB Assembly

Integrated Circuits

Reference Designator	Description	Vendor	Vendor Part Number	Note
M100	VOLTAGE DETECTOR, TSOP-5	ONSEMI	NCP303LSN30T1	4
M100	VOLTAGE DETECTOR, SOT-23-5	SEIKO	S-80930CNMC-G80-T2	4
M101	REGULATOR, 3.3V, 1A, TO-252	NEC	UPC2933T	4
M102	FLASH, MCU, 32K, LQFP64	RENASES	HD64F3664FP	4
M451	TRANSCEIVER, PDIP-8	TI	SN75176BP	4

Miscellaneous

Reference Designator	Description	Vendor	Vendor Part Number	Note
CN100	HEADER, RT ANG, 9 POS, P3.81	Dinkle	ECH381R-09P	4
CN101	HEADER, RT ANG, 9 POS, P3.81	Dinkle	ECH381R-09P	4
CN102	SHROUDED HEADER, TOP ENTRY, 8 CKT, P=2.5	Neltron	2317SJ-08	4
CN400	JACK, MODULAR, TM5RJ2-88	HIROSE	TM5RJ2-88	4
CN450	HEADER, RIGHT ANGLE, P2.74MM, 9 PINS	Omron	XM2C-0912-112	4
CN450	HEADER, RIGHT ANGLE, P2.74MM, 9 PINS	WIESON	3170-09MANS4DW	4
CN451	HEADER, RIGHT ANGLE, P5.08MM, 3 POLES, 2EHDRC-03P	DINKLE	2EHDRC-03P	4
XTAL300	32.768KHz, 20ppm, 12.5pF, D3X8MM	Raltron	R38-32.768-12.5	4
XTAL301	16.000MHz, 30ppm, 20pF, HC-49/S	Raltron	AS-16.000-20	4
XTAL400	20.000MHz, 30ppm, 20pF, HC-49/S	Raltron	AS-20.000-20	4
XTAL100	CRYSTAL, 10.000MHz, 30ppm, 20pF, HC-49/S	Raltron	AS-10.000-20	4
BT450	COIN CELL, LITHIUM BATTERY WITH SOLDERING TAB, BR2325	PANASONIC	BR2325-1HCE	4



# ELECTRICAL PART LIST

ESP-88 Output PCB Assembly

Inductors

Reference Designator	Description	Vendor Name	Vendor Part Number	Note
L900	NFM39R12C223	MURATA	NFM39R12C223	4
L901	NFM39R12C223	MURATA	NFM39R12C223	4
L902	NFM39R12C223	MURATA	NFM39R12C223	4
L903	NFM39R12C223	MURATA	NFM39R12C223	4
L904	NFM39R12C223	MURATA	NFM39R12C223	4
L905	NFM39R12C223	MURATA	NFM39R12C223	4
L906	NFM39R12C223	MURATA	NFM39R12C223	4
L907	NFM39R12C223	MURATA	NFM39R12C223	4
L908	NFM39R12C223	MURATA	NFM39R12C223	4
L909	NFM39R12C223	MURATA	NFM39R12C223	4
L910	NFM39R12C223	MURATA	NFM39R12C223	4
L911	NFM39R12C223	MURATA	NFM39R12C223	4

Miscellaneous

Reference Designator	Description	Vendor Name	Vendor Part Number	Note
CN900	STLZ950/3G-5.08	FENIX-CONTACT	STLZ950/3G-5.08	4
CN901	STLZ950/3G-5.08	FENIX-CONTACT	STLZ950/3G-5.08	4
CN902	STLZ950/3G-5.08	FENIX-CONTACT	STLZ950/3G-5.08	4
CN903	STLZ950/3G-5.08	FENIX-CONTACT	STLZ950/3G-5.08	4
CN904	OT1-400334	CT	OT1-400334	4

ESP-88 LED PCB Assembly

Diodes

Reference Designator	Description	Vendor	Vendor Part Number	Note
D920	LED, RED/GREEN	SHARP	GL3ED8(R/G)	4
D921	LED, RED/GREEN	SHARP	GL3ED8(R/G)	4
D922	LED, RED/GREEN	SHARP	GL3ED8(R/G)	4
D923	LED, RED/GREEN	SHARP	GL3ED8(R/G)	4
D924	LED, RED/GREEN	SHARP	GL3ED8(R/G)	4
D925	LED, RED/GREEN	SHARP	GL3ED8(R/G)	4
D926	LED, RED/GREEN	SHARP	GL3ED8(R/G)	4
D927	LED, RED/GREEN	SHARP	GL3ED8(R/G)	4

# ELECTRICAL PART LIST

CC-64 Control Center

Resistors

Reference Designator	Description	Vendor Name	Vendor Part Number	Note
RA100	NETWORK, 10K, 10 PIN/8R, 5%	Yageo	YC158TJR-0710K	4
RA400	NETWORK, 10K, 10 PIN/8R, 5%	Yageo	YC158TJR-0710K	4
RA401	NETWORK, 10K, 10 PIN/8R, 5%	Yageo	YC158TJR-0710K	4
RA500	NETWORK, 10K, 10 PIN/8R, 5%	Yageo	YC158TJR-0710K	4
R100	10K, 0603, 1/10W, 1%	Yageo	RC0603FR-0710K	4
R101	10K, 0603, 1/10W, 1%	Yageo	RC0603FR-0710K	4
R102	47 OHM, 0603, 1/10W, 5%	Yageo	RC0603JR-0747R	4
R103	47 OHM, 0603, 1/10W, 5%	Yageo	RC0603JR-0747R	4
R104	10K, 0603, 1/10W, 1%	Yageo	RC0603FR-0710K	4
R105	10K, 0603, 1/10W, 1%	Yageo	RC0603FR-0710K	4
R106	10K, 0603, 1/10W, 1%	Yageo	RC0603FR-0710K	4
R107	10K, 0603, 1/10W, 1%	Yageo	RC0603FR-0710K	4
R108	10K, 0603, 1/10W, 1%	Yageo	RC0603FR-0710K	4
R109	10K, 0603, 1/10W, 1%	Yageo	RC0603FR-0710K	4
R200	330 OHM, 0603, 1/10W, 1%	Yageo	RC0603FR-07330R	4
R201	47 OHM, 0603, 1/10W, 5%	Yageo	RC0603JR-0747R	4
R202	47 OHM, 0603, 1/10W, 5%	Yageo	RC0603JR-0747R	4
R203	330 OHM, 0603, 1/10W, 1%	Yageo	RC0603FR-07330R	4
R204	330 OHM, 0603, 1/10W, 1%	Yageo	RC0603FR-07330R	4
R205	100 OHM, 0603, 1/10W, 1%	Yageo	RC0603FR-07100R	4
R206	100 OHM, 0603, 1/10W, 1%	Yageo	RC0603FR-07100R	4
R208	10K, 0603, 1/10W, 1%	Yageo	RC0603FR-0710K	4
R209	4.7K, 0603, 1/10W, 1%	Yageo	RC0603FR-074K7	4
R210	330 OHM, 0603, 1/10W, 1%	Yageo	RC0603FR-07330R	4
R212	47 OHM, 0603, 1/10W, 5%	Yageo	RC0603JR-0747R	4
R216	10K, 0603, 1/10W, 1%	Yageo	RC0603FR-0710K	4
R300	56K, 0603, 1/10W, 1%	Yageo	RC0603FR-0756K	4
R400	10K, 0603, 1/10W, 1%	Yageo	RC0603FR-0710K	4
R401	10K, 0603, 1/10W, 1%	Yageo	RC0603FR-0710K	4
R402	10K, 0603, 1/10W, 1%	Yageo	RC0603FR-0710K	4
R403	10K, 0603, 1/10W, 1%	Yageo	RC0603FR-0710K	4
R404	0 OHM, 0603, 1/10W, 5%	Yageo	RC0603JR-07R00	4
R500	0 OHM, 0603, 1/10W, 5%	Yageo	RC0603JR-07R00	4
R501	10K, 0603, 1/10W, 1%	Yageo	RC0603FR-0710K	4
R502	0 OHM, 0603, 1/10W, 5%	Yageo	RC0603JR-07R00	4
R505	10K, 0603, 1/10W, 1%	Yageo	RC0603FR-0710K	4
R506	1K, 0603, 1/10W, 1%	Yageo	RC0603FR-071K	4
R509	680 OHM, 0603, 1/10W, 1%	Yageo	RC0603FR-07680R	4

Capacitors

Reference Designator	Description	Vendor Name	Vendor Part Number	Note
C100	12pF, 0603, NPO, 50V, 125C, 5%	Samsung	CL10C120JBNC	4
C101	12pF, 0603, NPO, 50V, 125C, 5%	Samsung	CL10C120JBNC	4
C102	10uF, SMD E CAP, 16V, 105C, 20%	Nichicon	UZT1C100MCR1GB	4
C103	0.1uF, 0603, Y5V, 50V, 85C, 20%	Samsung	CL10F104ZBNC	4
C104	0.1uF, 0603, Y5V, 50V, 85C, 20%	Samsung	CL10F104ZBNC	4

# ELECTRICAL PART LIST

CC-64 Control Center

Capacitors (continued)

Reference Designator	Description	Vendor Name	Vendor Part Number	
C105	0.1uF, 0603, Y5V, 50V, 85C, 20%	Samsung	CL10F104ZBNC	4
C106	0.1uF, 0603, Y5V, 50V, 85C, 20%	Samsung	CL10F104ZBNC	4
C107	0.1uF, 0603, Y5V, 50V, 85C, 20%	Samsung	CL10F104ZBNC	4
C108	0.1uF, 0603, Y5V, 50V, 85C, 20%	Samsung	CL10F104ZBNC	4
C109	0.1uF, 0603, Y5V, 50V, 85C, 20%	Samsung	CL10F104ZBNC	4
C110	0.1uF, 0603, Y5V, 50V, 85C, 20%	Samsung	CL10F104ZBNC	4
C200	1000pF, CER, Y5P, 2KV, 125C, 10%	Panasonic	ECKD3D102KBP	4
C201	0.01uF, 0603, X7R, 50V, 125C, 10%	Samsung	CL10B103KBNC	4
C202	0.01uF, 0603, X7R, 50V, 125C, 10%	Samsung	CL10B103KBNC	4
C203	12pF, 0603, NPO, 50V, 125C, 5%	Samsung	CL10C120JBNC	4
C204	12pF, 0603, NPO, 50V, 125C, 5%	Samsung	CL10C120JBNC	4
C205	0.1uF, 0603, Y5V, 50V, 85C, 20%	Samsung	CL10F104ZBNC	4
C206	0.1uF, 0603, Y5V, 50V, 85C, 20%	Samsung	CL10F104ZBNC	4
C207	0.1uF, 0603, Y5V, 50V, 85C, 20%	Samsung	CL10F104ZBNC	4
C208	0.1uF, 0603, Y5V, 50V, 85C, 20%	Samsung	CL10F104ZBNC	4
C209	0.1uF, 0603, Y5V, 50V, 85C, 20%	Samsung	CL10F104ZBNC	4
C210	0.1uF, 0603, Y5V, 50V, 85C, 20%	Samsung	CL10F104ZBNC	4
C211	0.1uF, 0603, Y5V, 50V, 85C, 20%	Samsung	CL10F104ZBNC	4
C213	0.1uF, 0603, Y5V, 50V, 85C, 20%	Samsung	CL10F104ZBNC	4
C214	1000pF, CER, Y5P, 2KV, 125C, 10%	Panasonic	ECKD3D102KBP	4
C300	0.1uF, 0603, Y5V, 50V, 85C, 20%	Samsung	CL10F104ZBNC	4
C301	22pF, 0603, NPO, 50V, 125C, 5%	Samsung	CL10C220JBNC	4
C302	10uF, SMD E CAP, 16V, 105C, 20%	Nichicon	UZT1C100MCR1GB	4
C400	0.1uF, 0603, Y5V, 50V, 85C, 20%	Samsung	CL10F104ZBNC	4
C401	0.1uF, 0603, Y5V, 50V, 85C, 20%	Samsung	CL10F104ZBNC	4
C402	0.1uF, 0603, Y5V, 50V, 85C, 20%	Samsung	CL10F104ZBNC	4
C403	0.1uF, 0603, Y5V, 50V, 85C, 20%	Samsung	CL10F104ZBNC	4
C404	0.01uF, 0603, X7R, 50V, 125C, 10%	Samsung	CL10B103KBNC	4
C405	0.01uF, 0603, X7R, 50V, 125C, 10%	Samsung	CL10B103KBNC	4
C406	0.01uF, 0603, X7R, 50V, 125C, 10%	Samsung	CL10B103KBNC	4
C407	0.01uF, 0603, X7R, 50V, 125C, 10%	Samsung	CL10B103KBNC	4
C408	0.01uF, 0603, X7R, 50V, 125C, 10%	Samsung	CL10B103KBNC	4
C409	0.01uF, 0603, X7R, 50V, 125C, 10%	Samsung	CL10B103KBNC	4
C410	0.01uF, 0603, X7R, 50V, 125C, 10%	Samsung	CL10B103KBNC	4
C411	0.01uF, 0603, X7R, 50V, 125C, 10%	Samsung	CL10B103KBNC	4
C412	0.01uF, 0603, X7R, 50V, 125C, 10%	Samsung	CL10B103KBNC	4
C413	0.01uF, 0603, X7R, 50V, 125C, 10%	Samsung	CL10B103KBNC	4
C500	220uF, SMD E CAP, 10V, 105C, 20%	Nichicon	UWT1A221MCL1GS	4
C501	0.1uF, 0603, Y5V, 50V, 85C, 20%	Samsung	CL10F104ZBNC	4
C502	0.1uF, 0603, Y5V, 50V, 85C, 20%	Samsung	CL10F104ZBNC	4
C503	0.1uF, 0603, Y5V, 50V, 85C, 20%	Samsung	CL10F104ZBNC	4
C504	0.1uF, 0603, Y5V, 50V, 85C, 20%	Samsung	CL10F104ZBNC	4
C505	220uF, SMD E CAP, 10V, 105C, 20%	Nichicon	UWT1A221MCL1GS	4
C507	0.1uF, 0603, Y5V, 50V, 85C, 20%	Samsung	CL10F104ZBNC	4
C508	0.1uF, 0603, Y5V, 50V, 85C, 20%	Samsung	CL10F104ZBNC	4
C509	10uF, E CAP, 16V, 105C, 20%	Nichicon	UZT1C100MCR1GB	4

# ELECTRICAL PART LIST

CC-64 Control Center

Diodes

Reference Designator	Description	Vendor Name	Vendor Part Number	
D100	SWITCHING, KDS181, SOT-23	KEC	KDS181	4
D101	SWITCHING, KDS181, SOT-23	KEC	KDS181	4
D102	SWITCHING, KDS181, SOT-23	KEC	KDS181	4
D200	LED, YELLOW, SMD, 0805	Everlight	17-21 UYC/S530-A2/TR8	4
D201	LED, AMBER, SMD, 0805	Everlight	17-21 UYOC/S530-A2/TR8	4
D202	LED, GREEN, SMD, 0805	Everlight	17-21 VGC/TR8	4
D300	LED, GREEN, SMD, 0805	Everlight	17-21 VGC/TR8	4
D301	LED, GREEN, SMD, 0805	Everlight	17-21 VGC/TR8	4
D302	LED, GREEN, SMD, 0805	Everlight	17-21 VGC/TR8	4
D303	LED, GREEN, SMD, 0805	Everlight	17-21 VGC/TR8	4
D304	LED, GREEN, SMD, 0805	Everlight	17-21 VGC/TR8	4
D305	LED, GREEN, SMD, 0805	Everlight	17-21 VGC/TR8	4
D306	LED, GREEN, SMD, 0805	Everlight	17-21 VGC/TR8	4
D307	LED, GREEN, SMD, 0805	Everlight	17-21 VGC/TR8	4
D308	LED, GREEN, SMD, 0805	Everlight	17-21 VGC/TR8	4
D309	LED, GREEN, SMD, 0805	Everlight	17-21 VGC/TR8	4
D310	LED, GREEN, SMD, 0805	Everlight	17-21 VGC/TR8	4
D311	LED, GREEN, SMD, 0805	Everlight	17-21 VGC/TR8	4
D312	LED, GREEN, SMD, 0805	Everlight	17-21 VGC/TR8	4
D313	LED, GREEN, SMD, 0805	Everlight	17-21 VGC/TR8	4
D314	LED, GREEN, SMD, 0805	Everlight	17-21 VGC/TR8	4
D315	LED, GREEN, SMD, 0805	Everlight	17-21 VGC/TR8	4
D316	LED, GREEN, SMD, 0805	Everlight	17-21 VGC/TR8	4
D317	LED, GREEN, SMD, 0805	Everlight	17-21 VGC/TR8	4
D318	LED, GREEN, SMD, 0805	Everlight	17-21 VGC/TR8	4
D319	LED, GREEN, SMD, 0805	Everlight	17-21 VGC/TR8	4
D320	LED, GREEN, SMD, 0805	Everlight	17-21 VGC/TR8	4
D321	LED, GREEN, SMD, 0805	Everlight	17-21 VGC/TR8	4
D322	LED, GREEN, SMD, 0805	Everlight	17-21 VGC/TR8	4
D323	LED, GREEN, SMD, 0805	Everlight	17-21 VGC/TR8	4
D324	LED, GREEN, SMD, 0805	Everlight	17-21 VGC/TR8	4
D325	LED, GREEN, SMD, 0805	Everlight	17-21 VGC/TR8	4
D326	LED, GREEN, SMD, 0805	Everlight	17-21 VGC/TR8	4
D327	LED, GREEN, SMD, 0805	Everlight	17-21 VGC/TR8	4
D328	LED, GREEN, SMD, 0805	Everlight	17-21 VGC/TR8	4
D329	LED, GREEN, SMD, 0805	Everlight	17-21 VGC/TR8	4
D330	LED, GREEN, SMD, 0805	Everlight	17-21 VGC/TR8	4
D331	LED, GREEN, SMD, 0805	Everlight	17-21 VGC/TR8	4
D332	LED, GREEN, SMD, 0805	Everlight	17-21 VGC/TR8	4
D333	LED, GREEN, SMD, 0805	Everlight	17-21 VGC/TR8	4
D334	LED, GREEN, SMD, 0805	Everlight	17-21 VGC/TR8	4
D335	LED, GREEN, SMD, 0805	Everlight	17-21 VGC/TR8	4
D336	LED, GREEN, SMD, 0805	Everlight	17-21 VGC/TR8	4
D337	LED, GREEN, SMD, 0805	Everlight	17-21 VGC/TR8	4
D338	LED, GREEN, SMD, 0805	Everlight	17-21 VGC/TR8	4

# ELECTRICAL PART LIST

CC-64 Control Center

Diodes (continued)

Reference Designator	Description	Vendor Name	Vendor Part Number	
D339	LED, GREEN, SMD, 0805	Everlight	17-21 VGC/TR8	4
D340	LED, GREEN, SMD, 0805	Everlight	17-21 VGC/TR8	4
D341	LED, GREEN, SMD, 0805	Everlight	17-21 VGC/TR8	4
D342	LED, GREEN, SMD, 0805	Everlight	17-21 VGC/TR8	4
D343	LED, GREEN, SMD, 0805	Everlight	17-21 VGC/TR8	4
D344	LED, GREEN, SMD, 0805	Everlight	17-21 VGC/TR8	4
D345	LED, GREEN, SMD, 0805	Everlight	17-21 VGC/TR8	4
D346	LED, GREEN, SMD, 0805	Everlight	17-21 VGC/TR8	4
D347	LED, GREEN, SMD, 0805	Everlight	17-21 VGC/TR8	4
D348	LED, GREEN, SMD, 0805	Everlight	17-21 VGC/TR8	4
D349	LED, GREEN, SMD, 0805	Everlight	17-21 VGC/TR8	4
D350	LED, GREEN, SMD, 0805	Everlight	17-21 VGC/TR8	4
D351	LED, GREEN, SMD, 0805	Everlight	17-21 VGC/TR8	4
D352	LED, GREEN, SMD, 0805	Everlight	17-21 VGC/TR8	4
D353	LED, GREEN, SMD, 0805	Everlight	17-21 VGC/TR8	4
D354	LED, GREEN, SMD, 0805	Everlight	17-21 VGC/TR8	4
D355	LED, GREEN, SMD, 0805	Everlight	17-21 VGC/TR8	4
D356	LED, GREEN, SMD, 0805	Everlight	17-21 VGC/TR8	4
D357	LED, GREEN, SMD, 0805	Everlight	17-21 VGC/TR8	4
D358	LED, GREEN, SMD, 0805	Everlight	17-21 VGC/TR8	4
D359	LED, GREEN, SMD, 0805	Everlight	17-21 VGC/TR8	4
D400	LED, GREEN, SMD, 0805	Everlight	17-21 VGC/TR8	4
D401	LED, GREEN, SMD, 0805	Everlight	17-21 VGC/TR8	4
D402	LED, GREEN, SMD, 0805	Everlight	17-21 VGC/TR8	4
D403	LED, GREEN, SMD, 0805	Everlight	17-21 VGC/TR8	4
D500	TVSSMAJ5.0CA-TR, SMA, ST	ST	SMAJ5.0CA-TR	4
D501	TVSSMAJ5.0CA-TR, SMA, ST	ST	SMAJ5.0CA-TR	4

## Inductors

Reference Designator	Description	Vendor Name	Vendor Part Number	
L200	10-BASE T LOW PASS FILTER	YCL	20F001N	4
L200	10-BASE T LOW PASS FILTER	BEL-FUSE	A556-2006-02	4
L201	CHIP, EMI FILTER, 50V/2A, 20%	Panasonic	EXCCET103U	4
L202	CHIP, EMI FILTER, 50V/2A, 20%	Panasonic	EXCCET103U	4
L502	CHIP, EMI FILTER, 50V/2A, 20%	Panasonic	EXCCET103U	4
L503	CHIP, EMI FILTER, 50V/2A, 20%	Panasonic	EXCCET103U	4

## Transistors

Reference Designator	Description	Vendor Name	Vendor Part Number	
Q100	PNP, 50V, 100mA, SOT-23	KEC	KRA102S	4
Q101	PNP, 50V, 100mA, SOT-23	KEC	KRA102S	4
Q102	PNP, 50V, 100mA, SOT-23	KEC	KRC102S	4
Q103	PNP, 50V, 100mA, SOT-23	KEC	KRA102S	4
Q202	PNP, 60V, 1A, SOT-89, KTA1668	KEC	KTA1668Y	4
Q500	PNP, 50V, 100mA, SOT-23	KEC	KRC102S	4



# ELECTRICAL PART LIST

CC-64 Control Center

Integrated Circuits

Reference Designator	Description	Vendor Name	Vendor Part Number	
M100	QUAD 2-INPUT AND, TSSOP14	ON Semi	MC74VHC08DT	4
M101	CMOS, SRAM, TSOP44	Samsung	K6R1016C1D-TC10	4
M102	MCU, FLASH, UNPROG, FP-100B	Hitachi	HD64F3069RF25	4
M200	HEX INVERTER, TSSOP14	ON Semi	MC74VHC04DT	4
M201	EEPROM, DIP8, ATMEL	ATMEL	AT93C46-10PI-2.7	4
M202	ETHERNET CONT, PQFP-100	Realtek	RTL8019AS	4
M300	LED DISPLAY DRIVER, QSOP16	MAXIM	MAX6951CEE	4
M400	DECODER, TSSOP16	ONSEMI	MC74VHC138DT	4
M401	OCTAL BUFFER DRIVER, TSSOP20	ON Semi	MC74VHC541DT	4
M402	OCTAL BUFFER DRIVER, TSSOP20	ON Semi	MC74VHC541DT	4
M403	OCTAL D-TYPE F-F, TSSOP20	ON Semi	MC74VHC574DT	4
M404	IDENTITY COMP, TSSOP20	Fairchild	74ACT521MTC	4
M500	DC/DC CONVERTER, DIP-24	Cincon Elec	EC5A-12S05	4
M501	VOLTAGE DETECTOR, TSOP-5	ON Semi	NCP303LSN47T1	4
M501	VOLTAGE DETECTOR, SOT-23-5	Seiko	S80947CNMC-G9H-T2	4
M503	OCTAL BUFFER DRIVER, TSSOP20	ON Semi	MC74VHC541DT	4
M504	OCTAL D-TYPE FLIP-FLIP, TSSOP20	ON Semi	MC74VHC574DT	4

## Miscellaneous

Reference Designator	Description	Vendor Name	Vendor Part Number	
CN100	CONNECTOR, 6POLE, P2.5MM	Neltron	2317SJ-06	4
CN200	MODULAR JACK, 7006-8P8C-M-01	Neltron	7006-8P8C-M-01	4
CN501	WIRE TO BOARD HEADER, P5.08MM, 2POLE, 2EHDVC-02P	Dinkle	2EHDVC-02P	4
CN503	PCB SOCKET, DUAL ROW, P2.54MM, 16POLE, H=7.1MM	Neltron	2214S-16G	4
E400	ENCODER, SW, 5P, 5V/10mA	ALPS	EC11E15244EF	4
E401	ENCODER, SW, 5P, 5V/10mA	ALPS	EC11E15244EF	4
E402	ENCODER, SW, 5P, 5V/10mA	ALPS	EC11E15244EF	4
E403	ENCODER, SW, 5P, 5V/10mA	ALPS	EC11E15244EF	4
E404	ENCODER, SW, 5P, 5V/10mA	ALPS	EC11E15244EF	4
JP500	HEADER, P2.54MM, 3PIN, H=6.0MM	Neltron	2211S-03G	4
JP501	HEADER, P2.54MM, 3PIN, H=6.0MM	Neltron	2211S-03G	4
LCM	HEADER, P2.54MM, 16PIN, H=6.0MM	Neltron	2213S-16G	4
SW400 SW401 SW402 SW403	TACT SW, SMT, 12V/50mA, 160g, H=5MM, TD-06XA	Wealth Metal	TD-06XAX	4
XTAL100	20.000MHz +/-30ppm, 20pF, HC-49/S	Raltron	AS-20.000-20	4
XTAL200	20.000MHz +/-30ppm, 20pF, HC-49/S	Raltron	AS-20.000-20	4
/JP500	JUMPER, CAP, 2 PIN, 6MM	Computime	22Z02-0611	4
/JP501	JUMPER, CAP, 2 PIN, 6MM	Computime	22Z02-0611	4
/LED PCB	FLAT CABLE, 18P, 2651, #26AWG, L=39MM, GREY, UL&CSA	Computime	3618BA00396K0Z04	4

# ELECTRICAL PART LIST

CC-16 Zone Controller

Resistors

Reference Designator	Description	Vendor Name	Vendor Part Number	Note
R1	715 OHM, 0603, 1/10W, 1%	Yageo Corporation	RC0603FR-07715R	4
R2	240 OHM, 0603, 1/10W, 1%	Yageo Corporation	RC0603FR-07240R	4
R3	100K, 0603, 1/10W, 5%	Yageo Corporation	RC0603JR-07100K	4
R4	10K, 0603, 1/10W, 5%	Yageo Corporation	RC0603JR-0710K	4
R5	10K, 0603, 1/10W, 5%	Yageo Corporation	RC0603JR-0710K	4
R8	10K, 0603, 1/10W, 5%	Yageo Corporation	RC0603JR-0710K	4
R6	120 OHM, 1206, 1/4W, 5%	Yageo Corporation	RC1206JR-07120R	4
R7	1.2K, 0603, 1/10W, 5%	Yageo Corporation	RC0603JR-071K2	4
R9	1.2K, 0603, 1/10W, 5%	Yageo Corporation	RC0603JR-071K2	4
R11	10K, 0603, 1/10W, 5%	Yageo Corporation	RC0603JR-0710K	4
R12	10K, 0603, 1/10W, 5%	Yageo Corporation	RC0603JR-0710K	4
R13	10K, 0603, 1/10W, 5%	Yageo Corporation	RC0603JR-0710K	4
R14	10K, 0603, 1/10W, 5%	Yageo Corporation	RC0603JR-0710K	4
R15	10K, 0603, 1/10W, 5%	Yageo Corporation	RC0603JR-0710K	4
R16	10K, 0603, 1/10W, 5%	Yageo Corporation	RC0603JR-0710K	4
R17	10K, 0603, 1/10W, 5%	Yageo Corporation	RC0603JR-0710K	4
R18	10K, 0603, 1/10W, 5%	Yageo Corporation	RC0603JR-0710K	4
R10	47K, 0603, 1/10W, 5%	Yageo Corporation	RC0603JR-0747K	4
R22	4.7K, 0603, 1/10W, 5%	Yageo Corporation	RC0603JR-074K7	4

Capacitors

Reference Designator	Description	Vendor Name	Vendor Part Number	Note
C1	47uF, 50V, SMD, ECAP, +105/-55C, 20%, D6.3x7.7	Nichicon Corp	UUD1H470MCR1GS	4
C2	100uF, 16V, SMD, ECAP, +105/-55C, 20%, D6.3X5.4	Nichicon Corp	UWT1C101MCR1GB	4
C3	20pF, 0603, 50V, NPO, 5%	Teamyoung Corp	0603N200J500BB	4
C4	20pF, 0603, 50V, NPO, 5%	Teamyoung Corp	0603N200J500BB	4
C5	220pF, 0603, 50V, NPO, 5%	Teamyoung Corp	0603N221J500BB	4
C6	0.1uF, 0603, X7R, 16V, 10%	Teamyoung Corp	0603B104K160BB	4
C7	0.1uF, 0603, X7R, 16V, 10%	Teamyoung Corp	0603B104K160BB	4
C8	0.1uF, 0603, X7R, 16V, 10%	Teamyoung Corp	0603B104K160BB	4
C9	0.1uF, 0603, X7R, 16V, 10%	Teamyoung Corp	0603B104K160BB	4
C10	0.1uF, 0603, X7R, 16V, 10%	Teamyoung Corp	0603B104K160BB	4
C11	0.1uF, 0603, X7R, 16V, 10%	Teamyoung Corp	0603B104K160BB	4
C12	0.1uF, 0603, X7R, 16V, 10%	Teamyoung Corp	0603B104K160BB	4

Diodes

Reference Designator	Description	Vendor Name	Vendor Part Number	Note
-	RECT, 400V/1A, SOD-106	Rohm Semi	1SR154-400	4
D1	SCHOTTKY BARR, SOD-80C	Philips Semi	BAS85	4
D2	SCHOTTKY BARR, SOD-80C	Philips Semi	BAS85	4
D3	SCHOTTKY BARR, SOD-80C	Philips Semi	BAS85	4
D4	SCHOTTKY BARR, SOD-80C	Philips Semi	BAS85	4

# ELECTRICAL PART LIST

CC-16 Zone Controller

Integrated Circuits

Reference Designator	Description	Vendor Name	Vendor Part Number	Note
U1	REG, 1.5A, TO-263 NS	National Semi	LM317S	4
U2	XCVR, SO-8, MAXIM	Maxim Integrated	MAX485ECSA	4
U3	EEPROM, 16Kx8, MSOP-8	Microchip Tech Inc	24LC128-I/MS	4
U4	MCU, SSOP28, 10MHz	Microchip Tech Inc	PIC16F873A-I/SS	4

Miscellaneous

Reference Designator	Description	Vendor Name	Vendor Part Number	Note
LCM	LCD MODULE, BSE002A, 122X32 DOT	ShanTou Goworld Co Ltd	SM4353	4
CN1	TERMINAL BLOCK, 6P, ELK508A-06P, P=5.08MM	Dinkle Enterprise Co Ltd	ELK508A-06P	4
CN2	HEADER, P2.54MM, DUAL, 20PIN, H7.5MM	Neltron Industrial Co Ltd	2213S-20G	4
SW1	DIP SWITCH, 8 POLE, SPST, ON/OFF, DS-08B	Diptronics Manufacturing Inc.	DS-08B	4
X1	CRYSTAL, 9.8304MHz +/- 30ppm, 20pF, HC-49/S	Raltron Electronics	AS-9.8304-20	4

# DISASSEMBLY PROCEDURES

## ControlSpace® ESP-88 Chassis

Refer to Figure 4 for the following procedures

### 1. Top Cover Removal

**1.1** Using a Phillips-head screwdriver, remove the eight screws (2, 3) that secure the top cover (1). There are six around the back and side edges of the cover and two at the front lip.

**1.2** Lift off the top cover.

### 2. Switch Mode Power Supply (SMPS) Removal

**2.1** Perform procedure 1.

**2.2** Disconnect the power supply AC wiring harness located toward the rear of the chassis (22). Disconnect the green ground wire from the GND terminal on the power supply. Disconnect the DC output connector located toward the front of the chassis. This cable harness connects to the motherboard.

**2.3** Using a Phillips-head screwdriver, remove the four screws that secure the power supply to the chassis. These screws are located on the bottom of the chassis. Lift out the power supply.

### 3. DC Fan Removal

**3.1** Perform procedure 2.

**3.2** Unplug the DC fan wiring harness from the motherboard at CN205.

**3.3** Remove the four screws (27) that secure the DC fan (28) to the chassis (22). Lift out the fan. Take care to not lose the nylon locknuts (29).

### 4. GPIO Board Removal

**4.1** Perform procedure 1.

**4.2** Using a Phillips-head screwdriver, remove the two screws (3) that secure the GPIO card (31) to the back of the chassis (22).

**4.3** Unplug the wire harness at CN102. Lift out the GPIO card.

**Note:** The chassis can support up to two GPIO cards at the end of the chassis nearest the power supply.

### 5. DSP PCB Removal

**5.1** Perform procedure 1.

**5.2** Using a Phillips-head screwdriver, remove the two screws (3) that secure the DSP card (30) to the back of the chassis (22).

**5.3** Lift up on the back of the DSP card until it unplugs from the motherboard (12) connector. Lift out the DSP card.

**Re-assembly Note:** When re-installing the card, ensure that the LEDs at the front edge of the card align with the openings in the front panel.

### 6. Mic/Line Input PCB Removal

**6.1** Perform procedure 1.

**6.2** Remove the one screw (3) that secures the LED PCB (25) to the front panel (21). This screw is located in the middle of the LED PCB at the front end of the Mic/Line Input PCB (10).

**6.3** Remove the two screws (3) that secure the back of the Mic/Line PCB to the chassis (22). These screws are located at the back of the chassis.

# DISASSEMBLY PROCEDURES

**6.4** Lift out the Mic/Line PCB assembly. Unplug the wiring harness for the Line Output PCB.

**Re-assembly Note:** When re-installing the Mic/Line PCB assembly, ensure that the LEDs located on the front of the LED PCB are aligned with the openings in the front panel.

## 7. Line Output PCB Removal

**7.1** Perform procedure 1.

**7.2** Remove the two screws (3) that secure the Line Output PCB assembly (9) to the chassis (22). Lift out the PCB assembly.

## 8. Motherboard PCB Removal

**8.1** Perform procedure 1.

**8.2** Remove all installed cards that plug into the motherboard (12) using the applicable disassembly procedures.

**8.3** Disconnect all GPIO and DC Switching Power Supply wiring harnesses from the motherboard PCB.

**8.4** Using a Phillips-head screwdriver, remove the twelve screws (3) that secure the motherboard to the chassis (22).

## ControlSpace® CC-16 Control Center

Refer to Figure 5 for the following procedures.

### 1. Front Plate Removal

**1.1** Grasp the edge of the front plate (1) and pull it away from the rest of the unit. The snaps should release and the front panel should come off easily.

### 2. Main PCB Removal

**2.1** On the back of the unit, release the two white clasps that secure the main PCB (5) in place and gently pull off it off the mounting frame (6).

### 3. LCD PCB Removal

**3.1** Perform procedure 2.

**3.2** If necessary, remove the front plate (1) using procedure 1.

**3.3** On the back of the mounting frame (5), release the two white plastic clips that secure the insert plate (3) and lift it off.

**3.4** On the front of the mounting frame, release the four white plastic clips that secure the LCD PCB (4) in place. Lift out the PCB.



# DISASSEMBLY PROCEDURES

## ControlSpace® CC-64 Control Center

Refer to Figure 6 for the following procedures.

### 1. Front Panel Removal

**1.1** Grasp the edge of the front panel (2) and pull it away from the rest of the unit. The snaps should release and the front panel should come off easily.

### 2. EMC Shield Removal

**2.1** Place the unit face down onto a soft surface.

**2.2** Using a Phillips-head screwdriver, remove the four screws (11) that secure the EMC shield (1).

**2.3** Lift off the EMC shield.

### 3. Main PCB Removal

**3.1** Pull off the five control knobs (3) from the front of the unit.

**3.2** Perform procedure 2.

**3.3** Unsolder the ribbon cable connections located at the left side of the main PCB (8) near the RJ-45 connector.

**3.4** Remove the four screws (11) that secure the Main PCB.

**3.5** Slide the Main PCB off of the posts and lift it off.

### 4. LED PCB Removal

**4.1** Perform procedure 3.

**4.2** Remove the five screws (11) that secure the LED PCB (7) to the front panel (9).

**4.3** Slide the PCB off of the posts and lift it off.

### 5. LCM Display Module Removal

**5.1** Perform procedure 3, but do not unsolder the ribbon cable connection to the Main PCB (8). You can swing the Main PCB out of the way to allow access to the LCM display module (6) screws.

**5.2** Remove the four screws (10) that secure the LCM display module in place.

**5.3** Lift off the LCM display module. Take care to not lose the four nylon washers (12) on the screws or the four nylon spacers under the LCM display module.

# Front Panel Indicators and Features

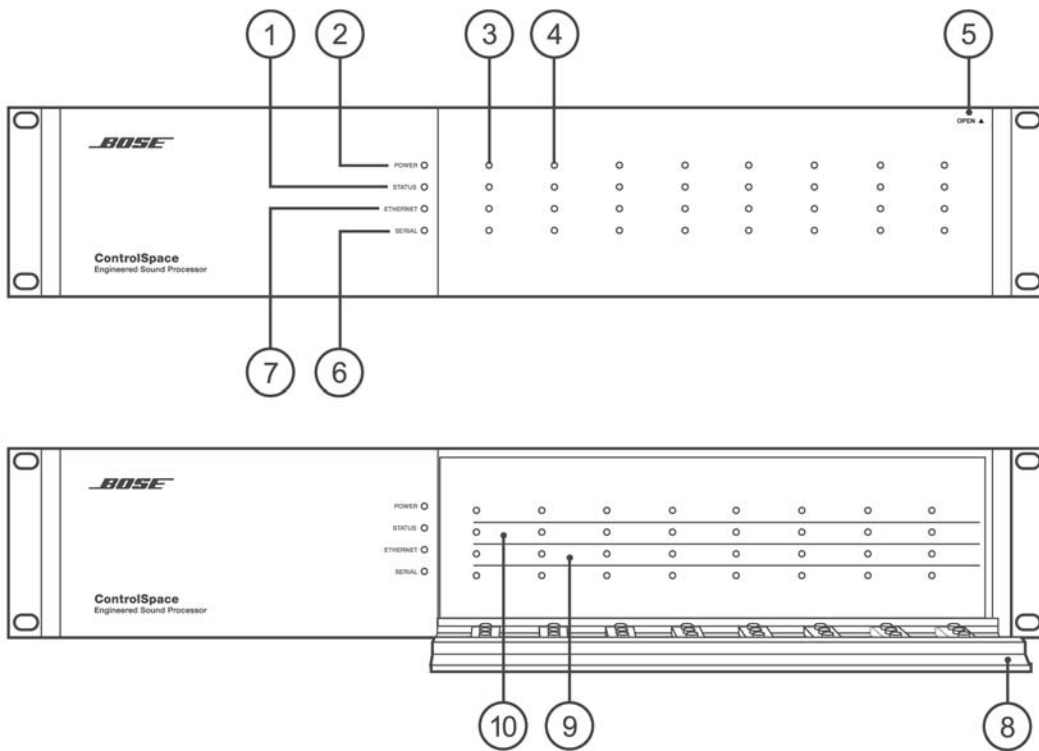

## 1. Status Indicator

- Green = Netlist loaded, operating
- Yellow = DSP resource shortage (delay or cycles)
- Red = Error in netlist
- Off = No netlist loaded

## 2. Power Indicator

- Green = Power on
- Red = Fatal error

## 3. Audio Input Indicator

- Green = Input signal  $> -36\text{dBu}/-60\text{dBFS}$
- Yellow = Input signal  $\geq +4\text{dBu}/-20\text{dBFS}$
- Red = Clipping, input signal  $\geq +18.0\text{dBu}/-6.0\text{dBFS}$

## 4. Audio Output Indicator

- Green = Output signal  $> -36\text{dBu}/-60\text{dBFS}$
- Yellow = Output signal  $\geq +4\text{dBu}/-20\text{dBFS}$
- Red = Clipping, output signal  $\geq +18.0\text{dBu}/-6.0\text{dBFS}$

## 5. Front Door

Shown closed, pull to open

## 6. Serial Indicator

- Red = RS232: Rx/Tx
- Yellow = RS485: CC-16 controller command received
- Green = RS485: CC-16 controller command transmitted

## 7. Ethernet Indicator

- Green = Link
- Yellow = Tx activity
- Red = Rx activity

## 8. Front Door

Shown open

## 9. Audio Output Label Area

Apply labels in this area to indicate the names of the output signals (e.g. "Center Fill")

## 10. Audio Input Label Area

Apply labels in this area to indicate the names of the output signals (e.g. "Podium Mic")

# Rear Panel Controls and Connections

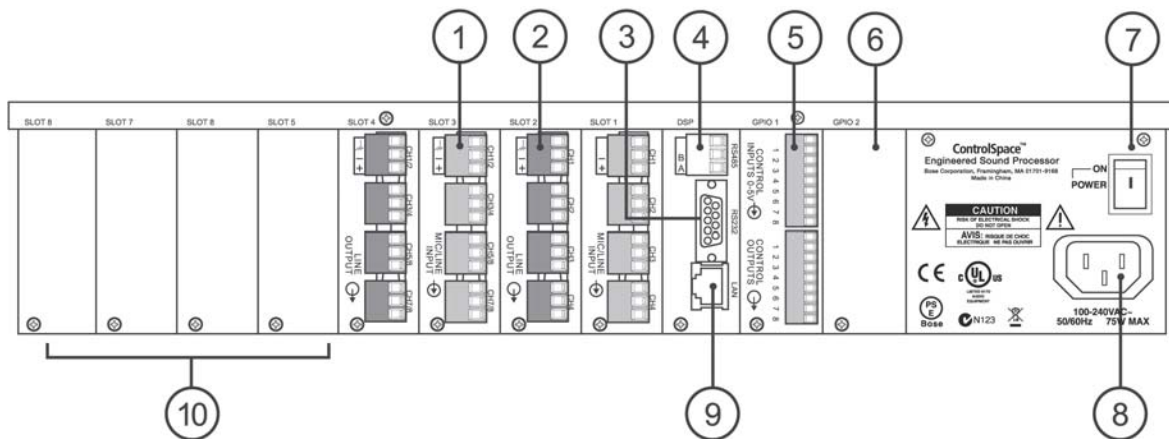

## 1. Mic/Line Inputs

Four balanced mic/line inputs (audio input connectors are green) in slots 1 and 3. These are inputs S1-1 through S1-4 and S3-1 through S3-4 in the ControlSpace™ Designer software

## 2. Line Outputs

Four balanced line outputs (audio output connectors are orange) in slots 2 and 4. These are outputs S2-1 through S2-4 and S4-1 through S4-4 in the Designer software

## 3. RS-232C Connector

DB-9 male (DTE)

## 4. RS-485 Connector

Connect ControlSpace CC-16 controllers

## 5. GPIO Card

Eight general purpose control inputs  
Eight general purpose control outputs

## RS-232C Serial Port

The ESP-88 features a serial port that can be used to send control signals to other equipment (such as a video switcher). The serial port is a DB9 male. The pin-out is shown at right.

## 6. GPIO slot 2

For optional second GPIO card

## 7. Power Switch

ON/OFF AC power

## 8. AC Cord Inlet

Connect the AC cord appropriate for your area

## 9. Ethernet LAN Connector

Connect to your PC with enclosed crossover cable. Or, connect directly to a hub or router with a straight-through cable

## 10. Audio Slots 5 - 8

For optional audio cards

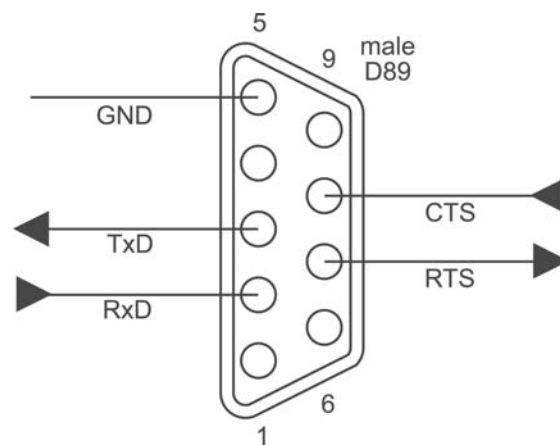

# Rear Panel Controls and Connections

## Mic/Line Inputs

The ESP-88 (base model) includes two “4x4” Mic/Line cards. Each of these cards occupy two slots. The input connectors (green) and the input LEDs appear in the first slot. The output connectors (orange) and LEDs appear in the second slot. A microphone or line level audio source can be connected to the Mic/Line inputs using one of the following cable types.

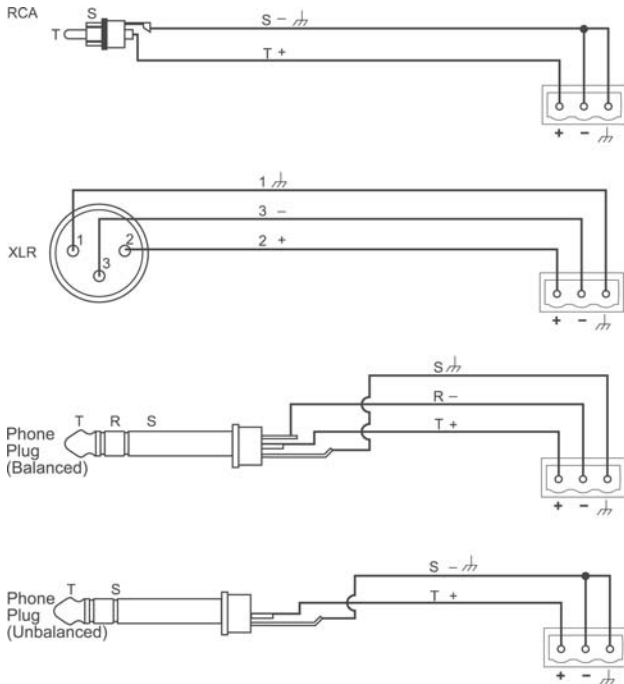

## General Purpose Inputs/Outputs

The ESP-88 (base model) includes one GPIO card in slot 1 providing eight control inputs and eight control outputs. A second card can be added to GPIO slot 2.

## Inputs

Switches and potentiometers can be connected to the control inputs to control various functions in the system. For example, simple ON/OFF switches can be connected and then programmed to invoke presets, select scenes, or invoke a snapshot of a control. Likewise, 10k linear potentiometers can be connected to control gains in the system.

Inputs contain a 5k ohm pull-up resistor allowing SPST switches to be wired from input to ground. Potentiometers can be wired in series from the control input to ground.

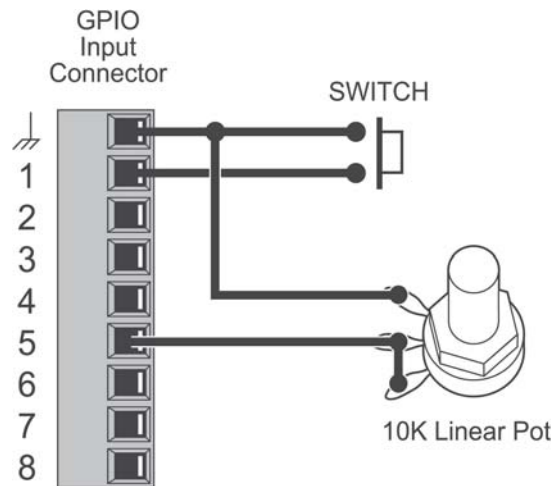

## Outputs

LEDs and relays can be connected to general purpose outputs to indicate state changes in the system (e.g. preset or scene changes).

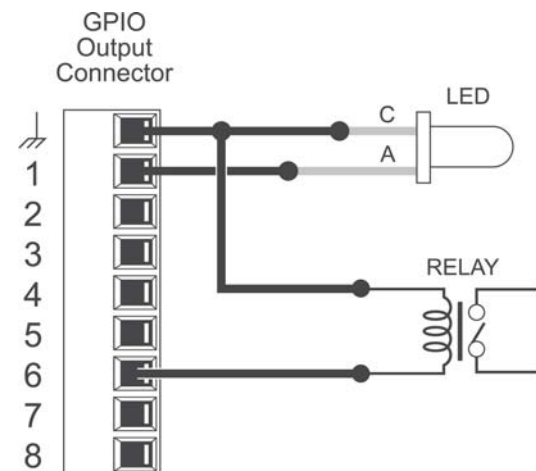

# TEST PROCEDURES

## Audio Processor ESP-88 Standard Version

### 1. Electrical Tests

#### Required Items

- Audio Precision ATS-2 test station
- Aubit ESP-88 test switchbox with cables and adapters
- Bose® CC-16 or CC-64 controller
- IBM Compatible PC with Microsoft® Windows® XP
- LAN Ethernet crossover cable
- DB9F to DB9F Null Modem cable
- Bose® ControlSpace™ software
- ATS-2 test station software
- Microsoft Excel

#### Test Setup Procedures

1. Ensure that the PC has valid IP address [192.168.0.1 – 192.168.0.99]. To set your IP address, click on START go to the CONTROL PANEL and click on NETWORK & DIAL UP CONNECTIONS. Click on MAKE NEW CONNECTION. Make a LAN connection. Click on PROPERTIES, then click on INTERNET PROTOCOL TCP/IP. Set the IP address to be between 192.168.0.1 and 192.168.0.99. The subnet mask will remain 255.255.255.0 and leave DNS settings window blank. Click OK.
  2. Connect the ESP-88 chassis under test to the AuBit switcher and the ATS-2 test station as shown in Figure 7.
  3. If not installed on the PC, install the Bose ControlSpace Designer software. Once the software is installed, click on the icon to start the program.
  4. Once the software opens, load the ESP88 TEST connection.csp file. This is a test file that is has the ESP-88 chassis pre-configured as a straight pass-through to allow test.
- If you don't have this file, perform the following steps to set up the software and hardware for test.

Once you open the ControlSpace software, you should see a blank project window like the one shown below.

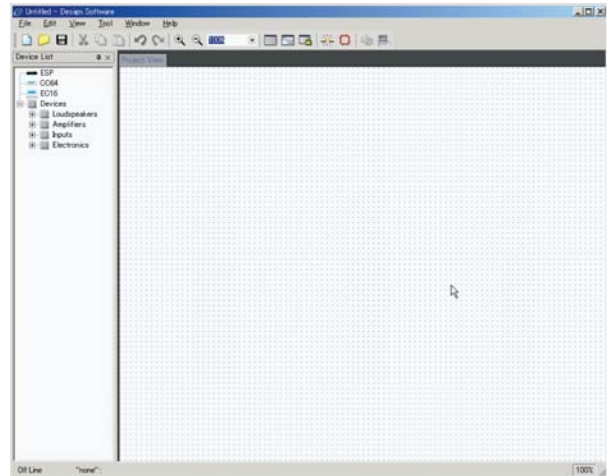

d. Click on "Scan".

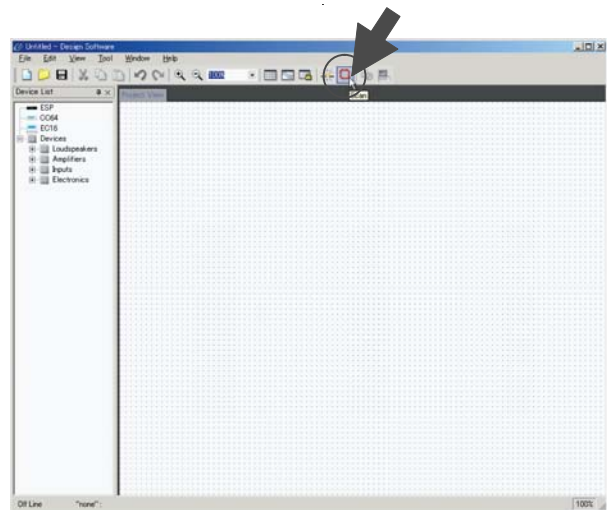

e. The connected ESP will appear on "Project view". This case has no Technic.

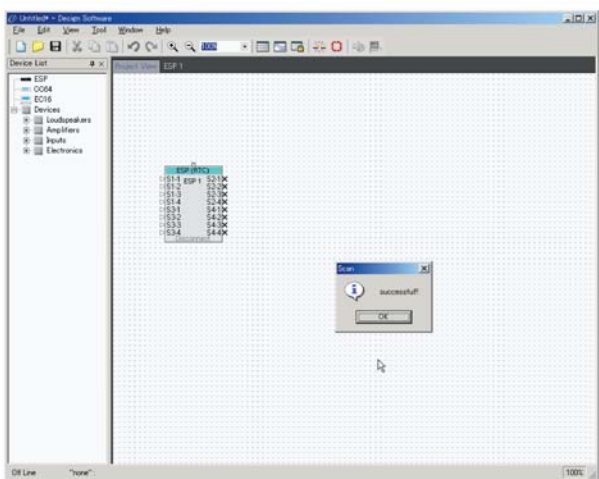



# TEST PROCEDURES

If there is no CC-16 or CC64 controller connected, connect it now. You will also need the power supply for the controller.

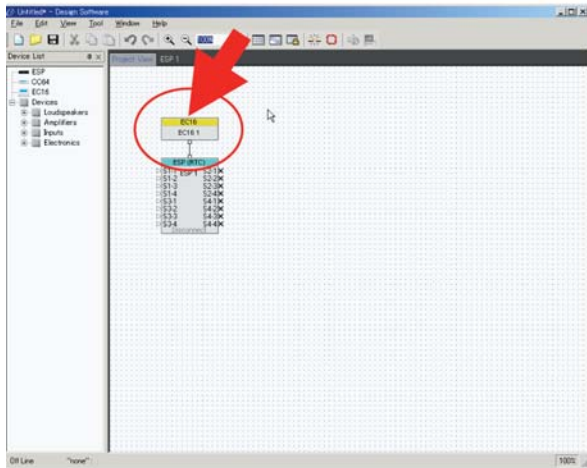

Click on the Properties view

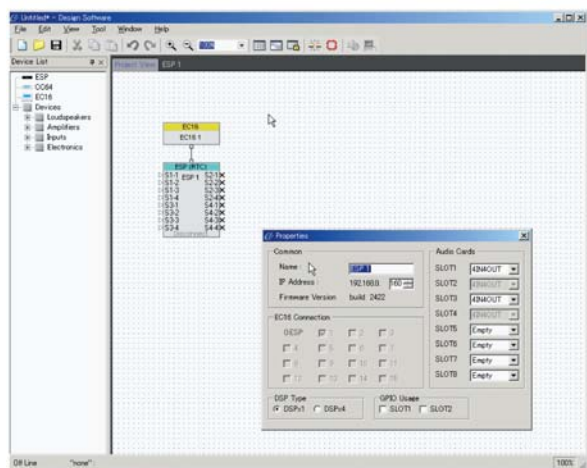

Check Firmware Version on properties dialog box. Select ESP 1 view.

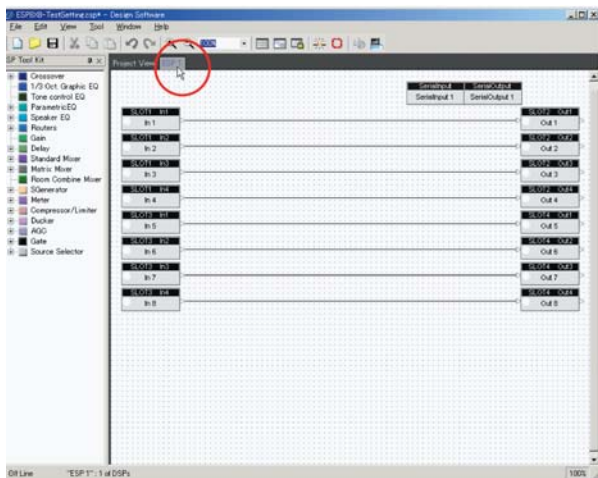

This setup is a straight-through connection for this test. Click the connect icon.

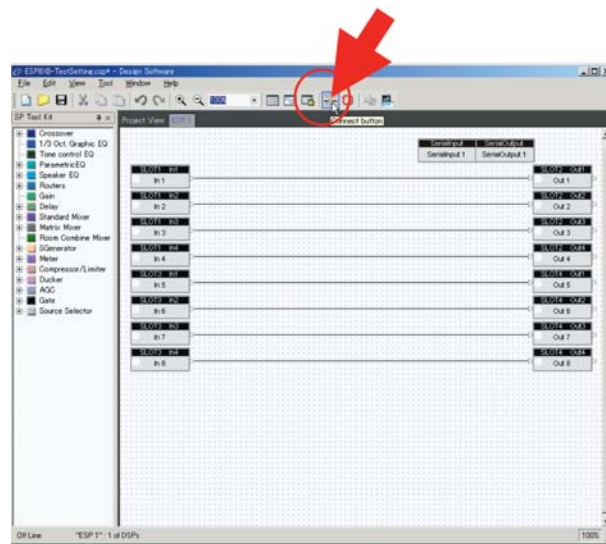

When the connection is completed, the background color will change.

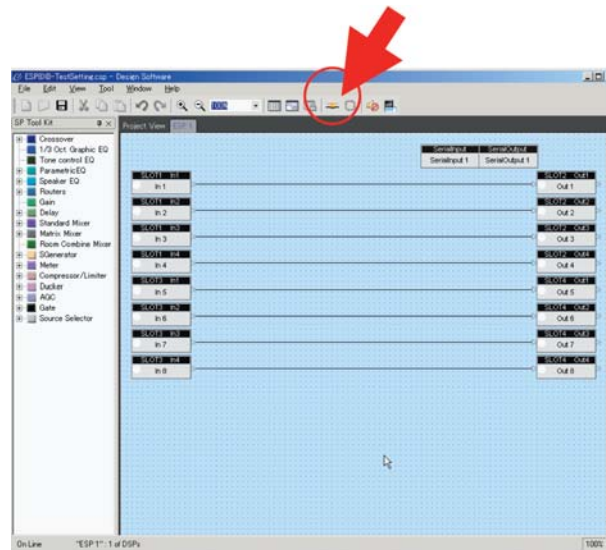

Click the connect icon again. At this point the ESP is settled to the proper configuration for this test.

After disconnect, the ESP-88 chassis must be powered off and powered on again.

This power off sequence is needed by the time test. It is recommended to use same PC that set this configuration and to run the ATS2 macro that will be described later. This will avoid the time difference between the two PC's.

# TEST PROCEDURES

## 4-2. Test Setup for the ControlSpace® ESP-88 Chassis

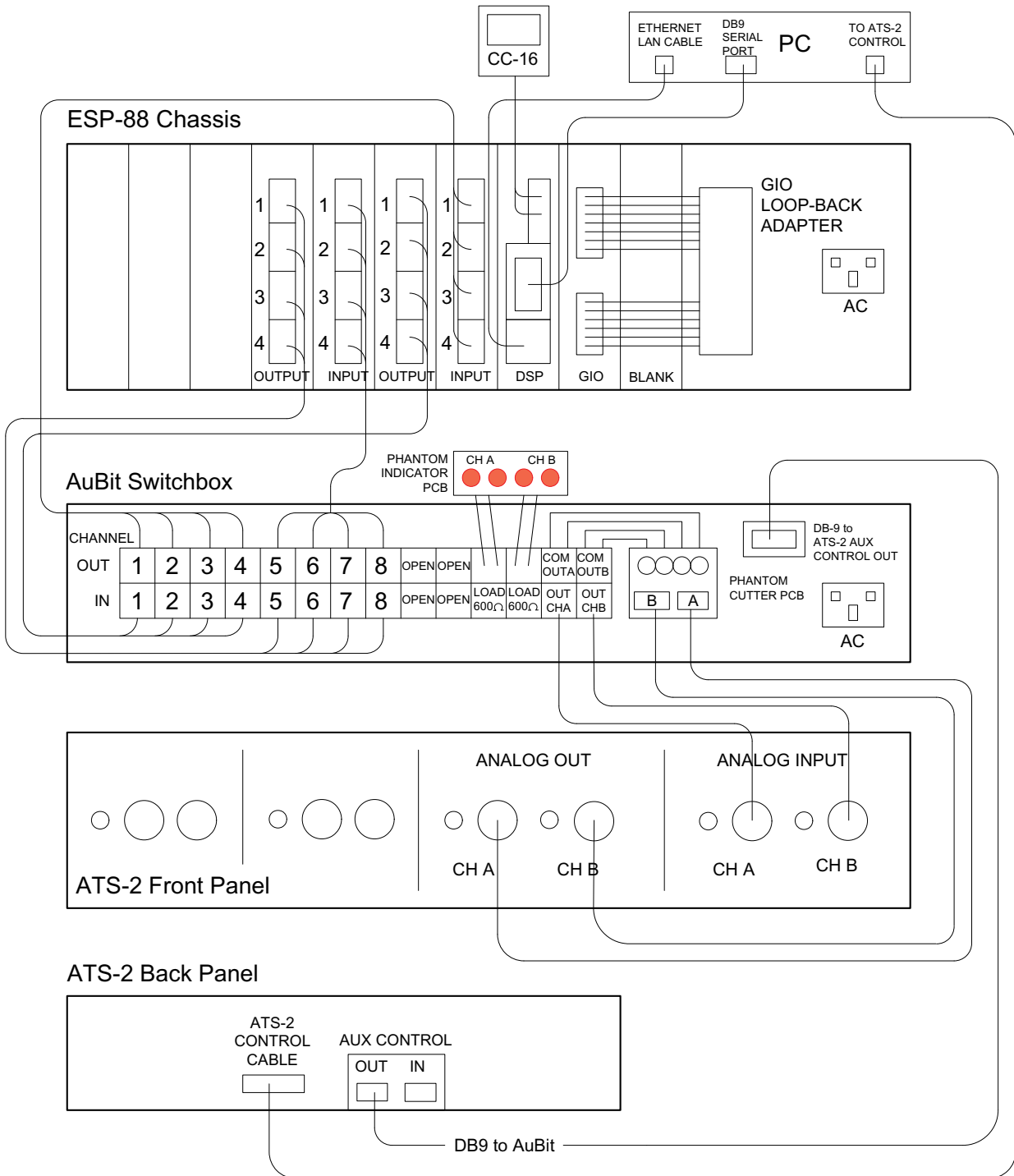

Figure 7. ATS-2, ESP-88 and AuBit Switchbox Test Setup Diagram

# TEST PROCEDURES

Table of connection between the ESP-88 and AuBit switcher

Switcher Outputs	ESP-88	ESP-88	Switcher Inputs
OUT CH1	Slot1 Input CH1	IN CH1	Slot2 Output CH1
OUT CH2	Slot1 Input CH2	IN CH2	Slot2 Output CH2
OUT CH3	Slot1 Input CH3	IN CH3	Slot2 Output CH3
OUT CH4	Slot1 Input CH4	IN CH4	Slot2 Output CH4
OUT CH5	Slot3 Input CH1	IN CH5	Slot4 Output CH1
OUT CH6	Slot3 Input CH2	IN CH6	Slot4 Output CH1
OUT CH7	Slot3 Input CH3	IN CH7	Slot4 Output CH1
OUT CH8	Slot3 Input CH4	IN CH8	Slot4 Output CH1
OUT OPT-1L	NC	IN OPT-1L	NC
OUT OPT-1R	NC	IN OPT-1R	NC
OUT OPT-2L	Phantom Checker CHA	IN OPT-2L	600ohm Load
OUT OPT-2R	Phantom Checker CHB	IN OPT-2R	600ohm Load
COM-L	ATS-2 Analog Output A	COM-L	ATS-2 Analog Input A
COM-R	ATS-2 Analog Output B	COM-R	ATS-2 Analog Input B

Caution ! COM-L and COM-R shall be connected with "Phantom cutter".

ESP-88 Chassis Configuration for test

ESP Slot	Card	Description
GIO2	Blank	Empty slot
GIO1	GIO	With 2.2k ohm Loop back cable.
DSP	DSP Main Card	Main card only - no expansion card
IO Slot 1	4x4 Main card	MIC/Line Input card
IO Slot 2	4x4 Output card	Line output card
IO Slot 3	4x4 Main card	MIC/Line Input card
IO Slot 4	4x4 Output card	Line output card
IO Slot 5	Blank	Empty slot
IO Slot 6	Blank	Empty slot
IO Slot 7	Blank	Empty slot
IO Slot 8	Blank	Empty slot

# TEST PROCEDURES

## Test Connection Photographs



Phantom Cutter



Connection of Phantom Cutter

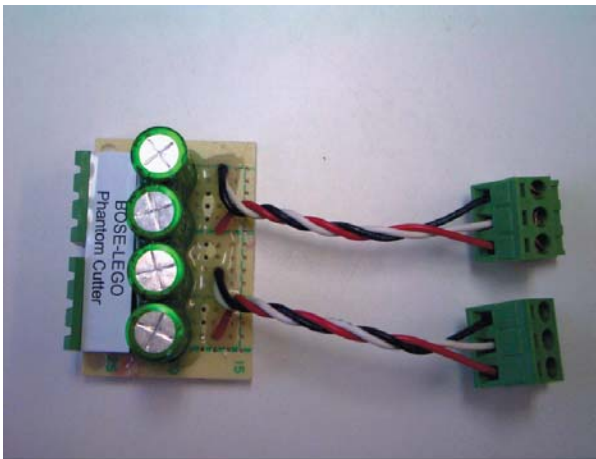

GIO 2.2k ohm loop back cable

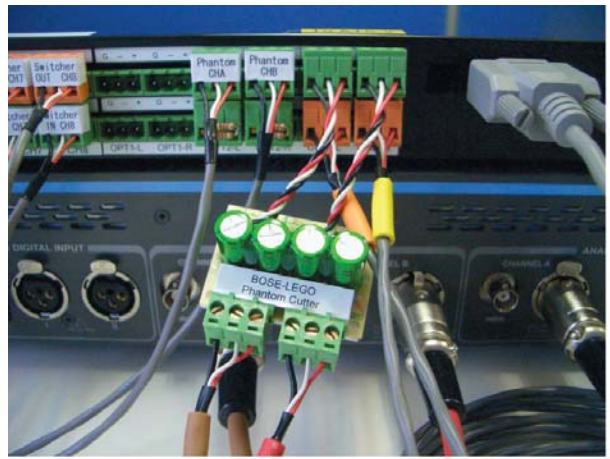



# TEST PROCEDURES

4-3. The order of testing. The table below lists the tests that are automatically performed by the ATS-2 test station test macro.

No	Test No	Test Gain or test item	Test Channel	1k	20	20k
1	5-1	Input 0dB / Output +4dBu	Input 1/2 ~ Output 1/2	Do	Do	Do
2			Input 3/4 ~ Output 3/4	Do	Do	Do
3			Input 5/6 ~ Output 5/6	Do	Do	Do
4			Input 7/8 ~ Output 7/8	Do	Do	Do
5	5-2	Input +14dB / Output +4dBu	Input 1/2 ~ Output 1/2	Do	-	-
6			Input 3/4 ~ Output 3/4	Do	-	-
7			Input 5/6 ~ Output 5/6	Do	-	-
8			Input 7/8 ~ Output 7/8	Do	-	-
9	5-3	Input +24dB / Output +4dBu	Input 1/2 ~ Output 1/2	Do	-	-
10			Input 3/4 ~ Output 3/4	Do	-	-
11			Input 5/6 ~ Output 5/6	Do	-	-
12			Input 7/8 ~ Output 7/8	Do	-	-
13	5-4	Input +42dB / Output +4dBu	Input 1/2 ~ Output 1/2	Do	-	-
14			Input 3/4 ~ Output 3/4	Do	-	-
15			Input 5/6 ~ Output 5/6	Do	-	-
16			Input 7/8 ~ Output 7/8	Do	-	-
17	5-5	Input 48dB / Output +4dBu	Input 1/2 ~ Output 1/2	Do	Do	Do
18			Input 3/4 ~ Output 3/4	Do	Do	Do
19			Input 5/6 ~ Output 5/6	Do	Do	Do
20			Input 7/8 ~ Output 7/8	Do	Do	Do
21	5-6	Input 54dB / Output +4dBu	Input 1/2 ~ Output 1/2	Do	-	-
22			Input 3/4 ~ Output 3/4	Do	-	-
23			Input 5/6 ~ Output 5/6	Do	-	-
24			Input 7/8 ~ Output 7/8	Do	-	-
25	5-7	Input 64dB / Output +4dBu	Input 1/2 ~ Output 1/2	Do	Do	Do
26			Input 3/4 ~ Output 3/4	Do	Do	Do
27			Input 5/6 ~ Output 5/6	Do	Do	Do
28			Input 7/8 ~ Output 7/8	Do	Do	Do
29	5-8	Input 0dB / Output -10dBu	Input 1/2 ~ Output 1/2	Do	Do	Do
30			Input 3/4 ~ Output 3/4	Do	Do	Do
31			Input 5/6 ~ Output 5/6	Do	Do	Do
32			Input 7/8 ~ Output 7/8	Do	Do	Do
33	6	Phantom test (Hand Pass/Fail)	Input 1 ~ 8	-	-	-
34	7	GIO	GIO bit 0 ~ 7	-	-	-
35	8	Time	ESP internal time	-	-	-
36	9	LAN				
37	10	RS232C				
38	11	RS485(Hand Pass/Fail)				



# TEST PROCEDURES

## 4-4. Fundamental Setting of ATS-2

### 4-4-1. Analog Generator Setting.

Item	Setting
Wave form	Sine(Normal)
Frequency	1kHz
Out puts	A/B-ON
Track	Track-A
Amplitude	+4.00dBu
Configuration	Bal XLR
Z-Out(Ohms)	40

### 4-4-2. Analog Input Setting.

Item	Setting
Source	XLR-Bal (Both A/B Channel)
Peak Monitor	Set the units "dBu"
Auto Range	Check
DC	No Check

### 4-4-3. Analyzer Setting.

Item	Setting
Instrument	Audio Analyzer
Input	Analog
Level	Set the units "dBu"
Frequency	Set the units "kHz"
Range	Check both
Measurement Function	THD+N Ratio
Function	Set the units "%"
Range	Check both
Detect	Auto-RMS
Band width	22Hz~20kHz LPF
BP/BR filter	Sweep Track
frequency	
Filter	"A" weighting

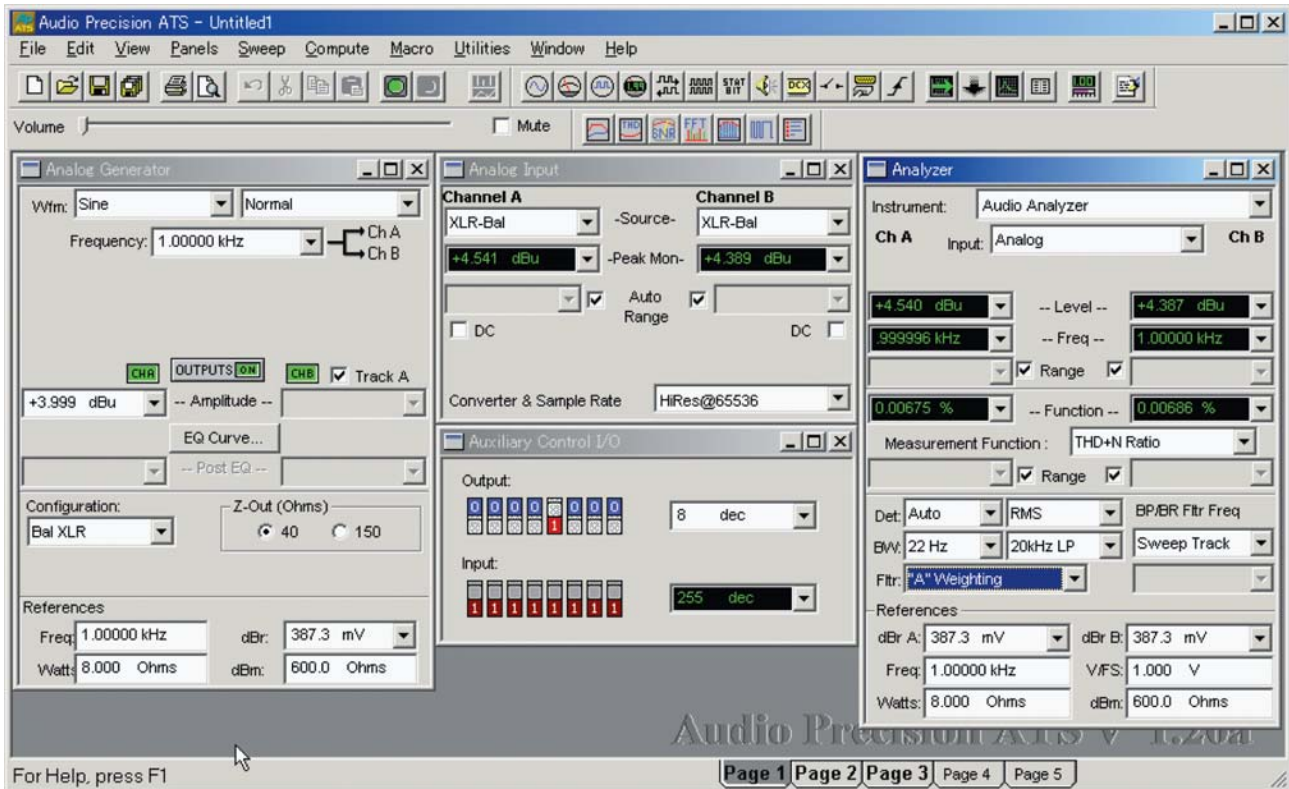

# TEST PROCEDURES

## 4-5. Automatic test setting on ATS2.

Load the ATS2 macro file “ESP88 TestMacro.atsb”. Click on the Macro Editor button. The Macro Editor window shown at the bottom of the page will open. **CAUTION:** Do not change any of the text in the Macro Editor window, or you will change the test parameters, corrupting the test file and causing the test to fail.

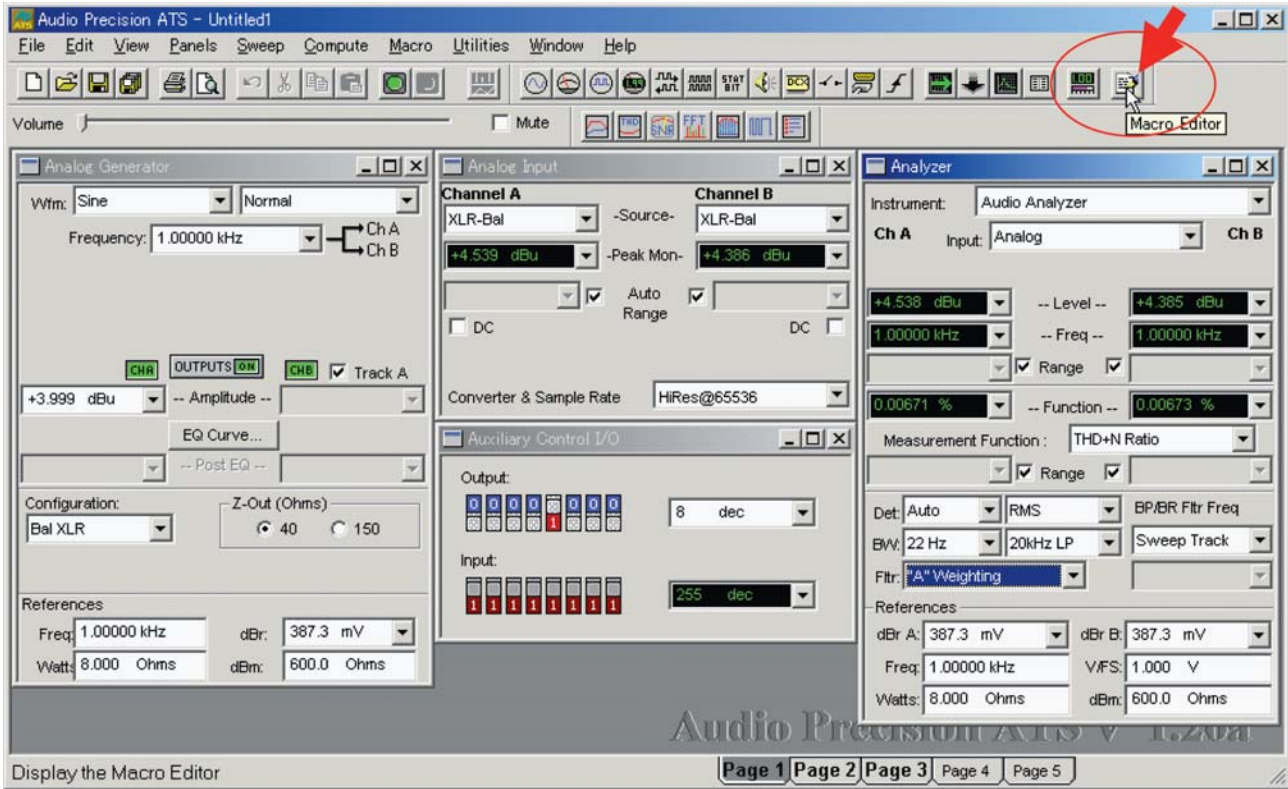

Click on the START/RESUME button in the Macro Editor window toolbar.

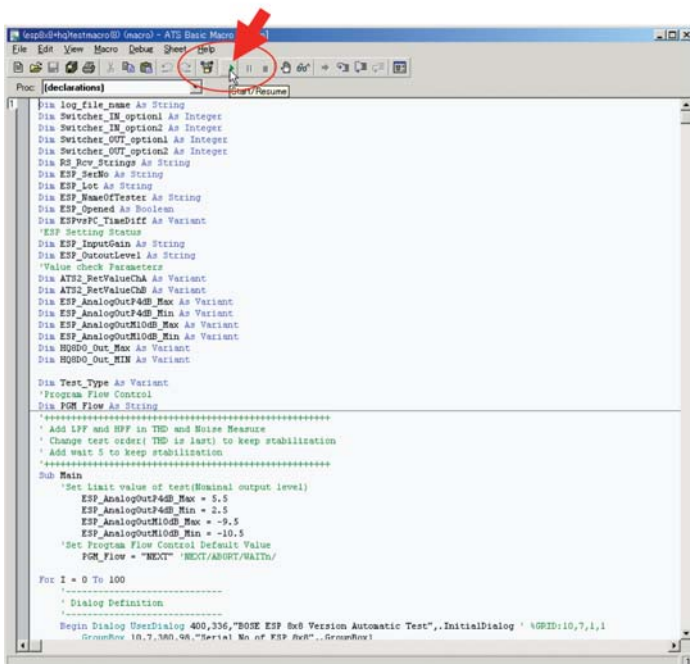

# TEST PROCEDURES

## 4-6. About Automatic test setting on ATS2.

This macro file “ESP88 TestMacro.atsb” can measure all items listed in section 4-3. The order of testing.

Audio quality can be measured and logged automatically.

When you click on the START/RESUME button in the Macro Editor window toolbar, the dialog box shown at right will appear on the screen. Make sure the ESP 8X8 Version radio button is checked. Input the serial number, lot number, tester's name and push START TEST button.

Once you click the start button, the file save dialog box will appear. The serial number is used for the file name. There is no need to change the file name, but if you wish to change the directory you save to, select the proper directory.

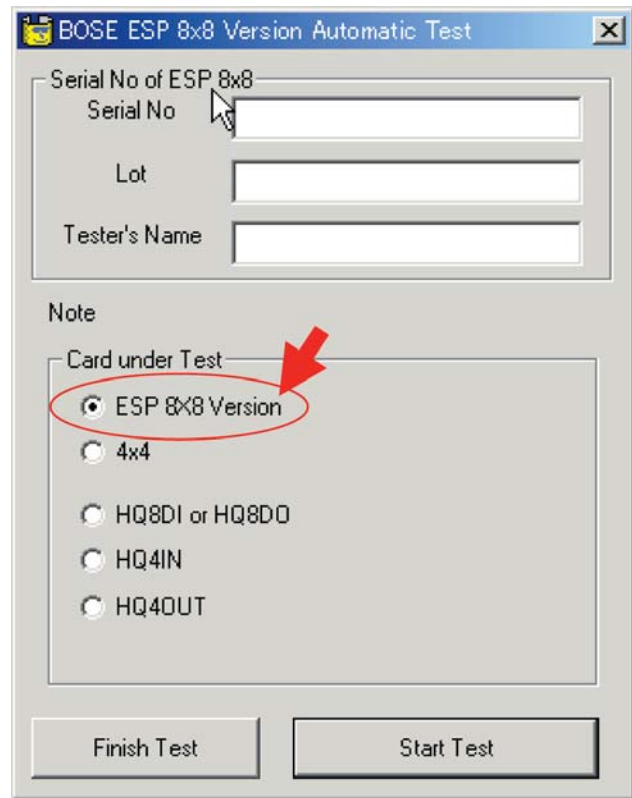

If a test fails, the dialog box at right will appear on the screen and ask if you would like to continue or not.

This message show the ESP that is tested has a fault. If you would like to get information for repair by saving a log file, you can continue by pushing the YES button to generate a log file. You can terminate the test by pushing the NO button to end the test.

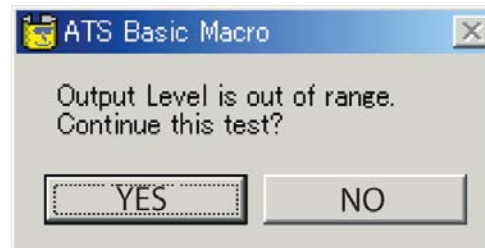

The dialog box at right shows the progress of the test.

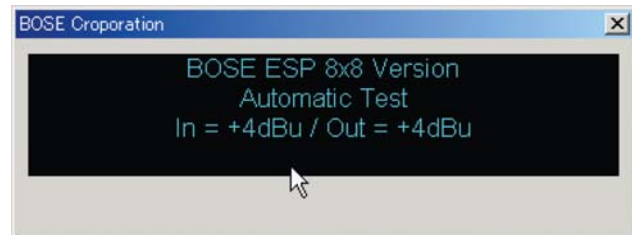

This “Auxiliary Control I/O” dialog box shows the status of Aubit switcher.

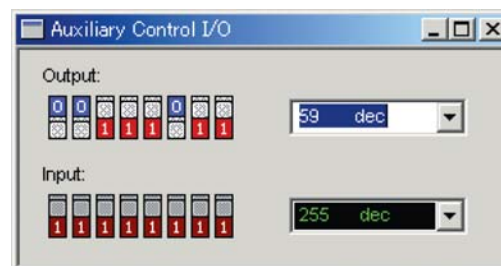

# TEST PROCEDURES

## 4-7. Phantom Power test on the ATS2.

The Phantom test is done by the Phantom checker hardware. This test will proceed automatically.

## 4-8. RS485 test on the ATS2.

The RS485 test is performed by checking to see if the unit can see the CC-16 controller that is connected to the RS485 connector.

The CC-16 icon will appear in the ControlSpace® test window when the CC-16 is connected to ESP-88.

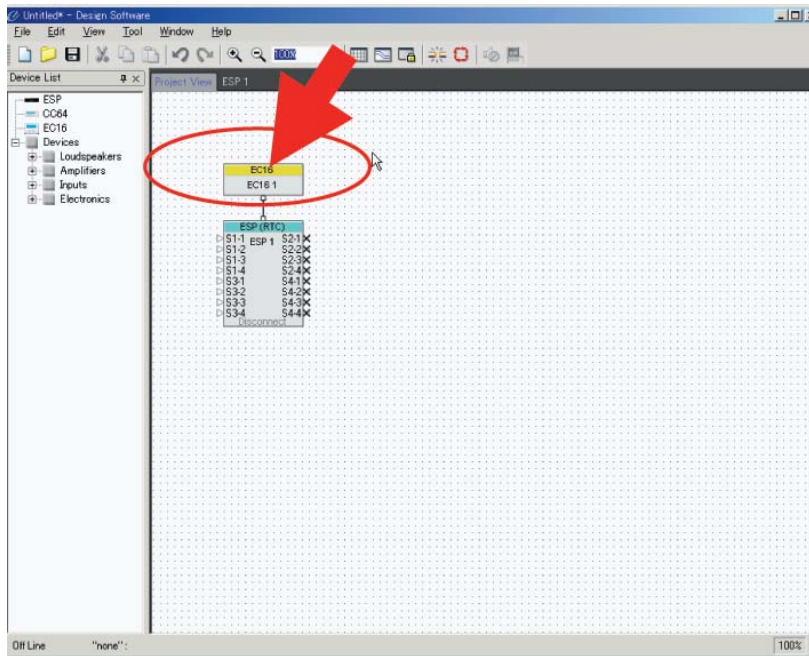

This test will proceed automatically.

When “EC16” is detected, “Pass” is logged to the log file automatically.

When “EC16” is not detected, “Fail” is logged to the log file automatically.

The address of the CC-16 should be set anywhere from 1 to 15. Refer to the diagram below.

When the CC-16 controller is detected by the software through the chassis, this test will pass.

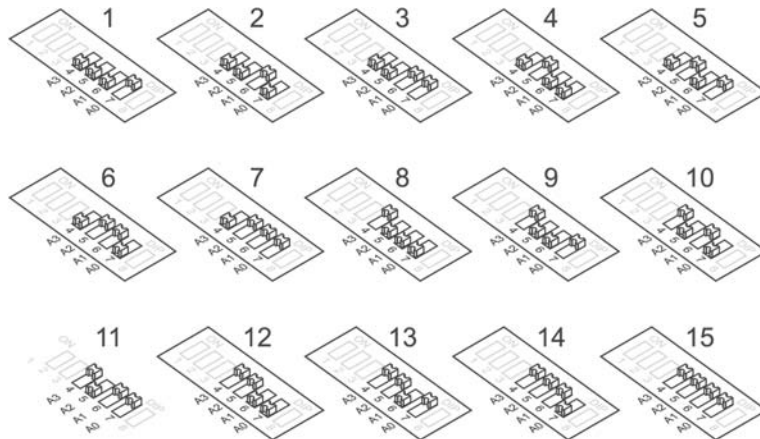

**CC-16 DIP Switch Settings**



# TEST PROCEDURES

## 4-9. Test log file.

This test will be saved automatically as a text file with the file name specified in step 4.6.  
The text file format is as shown below.

```
LEGO 8x8 Standard Version TEST
Serial No=2035623Z434500026AE
Lot=2005/06
Tester's Name=N,Maeda(AuBit)
Logged Date = 2005,06,23
Start Time = 22:33:40
-----
21.[MAC-ADDR] = 00-0C-8A-00-11-11
22.[IP-ADDR] = 192.168.0.160
32.[Firmware-version] = 2755
33.[number-of-DSPs] = 1
-----
Gain Setting= IN=+4dBu / OUT=+4dBu
Measure CH = IN=CH 1(L/R) - OUT=CH 1(L/R)
AMPL(Analog),CHA=3.9303,CHB=3.7633,OSC-Level= 4,OSC-Frq= 1000,Filt=None,Unit=dBu
AMPL(Analog),CHA=3.2516,CHB=2.8487,OSC-Level= 4,OSC-Frq=
20000,Filt=None,Unit=dBu
AMPL(Analog),CHA=3.4804,CHB=3.3147,OSC-Level= 4,OSC-Frq= 20,Filt=None,Unit=dBu
NOIS(Analog),CHA=-81.548,CHB=-80.5375,OSC-Level= ,OSC-Frq= ,Filt=AWTG,Unit=dBu
THD(Analog),CHA=.013491,CHB=.011558,OSC-Level= 23.5,OSC-Frq=
1000,Filt=AWTG,Unit=%
THD(Analog),CHA=.007371,CHB=.009276,OSC-Level= 4,OSC-Frq= 1000,Filt=AWTG,Unit=%
Measure CH = IN=CH 2(L/R) - OUT=CH 2(L/R)
AMPL(Analog),CHA=3.9665,CHB=3.9353,OSC-Level= 4,OSC-Frq= 1000,Filt=None,Unit=dBu
AMPL(Analog),CHA=2.9984,CHB=3.161,OSC-Level= 4,OSC-Frq= 20000,Filt=None,Unit=dBu
AMPL(Analog),CHA=3.5142,CHB=3.4718,OSC-Level= 4,OSC-Frq= 20,Filt=None,Unit=dBu
NOIS(Analog),CHA=-81.4168,CHB=-81.403,OSC-Level= ,OSC-Frq= ,Filt=AWTG,Unit=dBu
THD(Analog),CHA=.01758,CHB=.019736,OSC-Level= 23.5,OSC-Frq=
1000,Filt=AWTG,Unit=%
THD(Analog),CHA=.005462,CHB=.007725,OSC-Level= 4,OSC-Frq= 1000,Filt=AWTG,Unit=%
Measure CH = IN=CH 3(L/R) - OUT=CH 3(L/R)
AMPL(Analog),CHA=3.9494,CHB=3.9122,OSC-Level= 4,OSC-Frq= 1000,Filt=None,Unit=dBu
AMPL(Analog),CHA=2.7318,CHB=3.0089,OSC-Level= 4,OSC-Frq=
20000,Filt=None,Unit=dBu
AMPL(Analog),CHA=3.5008,CHB=3.4623,OSC-Level= 4,OSC-Frq= 20,Filt=None,Unit=dBu
NOIS(Analog),CHA=-81.677,CHB=-79.271,OSC-Level= ,OSC-Frq= ,Filt=AWTG,Unit=dBu
THD(Analog),CHA=.02402,CHB=.023341,OSC-Level= 23.5,OSC-Frq=
1000,Filt=AWTG,Unit=%
THD(Analog),CHA=.005817,CHB=.010444,OSC-Level= 4,OSC-Frq= 1000,Filt=AWTG,Unit=%
Measure CH = IN=CH 4(L/R) - OUT=CH 4(L/R)
AMPL(Analog),CHA=3.8893,CHB=3.9235,OSC-Level= 4,OSC-Frq= 1000,Filt=None,Unit=dBu
AMPL(Analog),CHA=2.9661,CHB=3.0667,OSC-Level= 4,OSC-Frq=
20000,Filt=None,Unit=dBu
AMPL(Analog),CHA=3.4386,CHB=3.4648,OSC-Level= 4,OSC-Frq= 20,Filt=None,Unit=dBu
NOIS(Analog),CHA=-81.408,CHB=-81.4305,OSC-Level= ,OSC-Frq= ,Filt=AWTG,Unit=dBu
THD(Analog),CHA=.021664,CHB=.022501,OSC-Level= 23.5,OSC-Frq=
```



# TEST PROCEDURES

4-10. Pass/Fail evaluation and report of this test.

The log file data must be checked for each item.

The Excel test file “ESPTestReporter.xls” can check all of the items that are logged. This file has a macro to load the data from the log data text (.txt) file.

**Total Pass/Fail result.**

**AuBit**

Device under test: \_\_\_\_\_ According to OT1-1

Serial Number: \_\_\_\_\_  
 Lot: \_\_\_\_\_  
 Date of test: \_\_\_\_\_  
 Tester's Name: \_\_\_\_\_

**Result FAIL**

**Here is criteria.**

**Total Result FALSE**

		CH1	CH2	CH3	CH4	CH5	CH6	CH7	CH8
5-1.(GV=0dB)	AMPL								
	Nois								
	FRQ20K								
	FRQ20								
	THDN								
5-2.(GV=+14dB)	AMPL								
	Nois								
	FRQ20K								
	FRQ20								
	THDN								
5-3.(GV=+24dB)	AMPL								
	Nois								
	FRQ20K								
	FRQ20								
	THDN								
5-4.(GV=+42dB)	AMPL								
	Nois								
	FRQ20K								
	FRQ20								
	THDN								
5-5.(GV=+48dB)	AMPL								
	Nois								
	FRQ20K								
	FRQ20								
	THDN								
5-6.(GV=+54dB)	AMPL								
	Nois								
	FRQ20K								
	FRQ20								
	THDN								
5-7.(GV=+64dB)	AMPL								
	Nois								
	FRQ20K								
	FRQ20								
	THDN								
5-8.OUT-10dBu (GV=+0dB)	AMPL								
	Nois								
	FRQ20K								
	FRQ20								
	THDN								
6.Phantom test	Pass/Fail								
7.GIO test(Full)	%								
7.GIO test(Half)	%								

**Logged data will be loaded in this area.**

		Total	Max	Min	CH1	CH2	CH3	CH4	CH5	CH6	CH7	CH8
5-1.(GV=0dB)	AMPL	FALSE	5.5	2.5	FALSE	FALSE	FALSE	FALSE	FALSE	FALSE	FALSE	FALSE
	Nois	FALSE	-77	-200	FALSE	FALSE	FALSE	FALSE	FALSE	FALSE	FALSE	FALSE
	FRQ20K	FALSE	4.5	1.5	FALSE	FALSE	FALSE	FALSE	FALSE	FALSE	FALSE	FALSE
	FRQ20	FALSE	5.5	2.5	FALSE	FALSE	FALSE	FALSE	FALSE	FALSE	FALSE	FALSE
	THDN	FALSE	0.015	0	FALSE	FALSE	FALSE	FALSE	FALSE	FALSE	FALSE	FALSE
5-2.(GV=+14dB)	AMPL	FALSE	5.5	2.5	FALSE	FALSE	FALSE	FALSE	FALSE	FALSE	FALSE	FALSE
	Nois	FALSE	-77	-200	FALSE	FALSE	FALSE	FALSE	FALSE	FALSE	FALSE	FALSE
	FRQ20K	FALSE	4.5	1.5	FALSE	FALSE	FALSE	FALSE	FALSE	FALSE	FALSE	FALSE
	FRQ20	FALSE	5.5	2.5	FALSE	FALSE	FALSE	FALSE	FALSE	FALSE	FALSE	FALSE
	THDN	FALSE	0.015	0	FALSE	FALSE	FALSE	FALSE	FALSE	FALSE	FALSE	FALSE
5-3.(GV=+24dB)	AMPL	FALSE	5.5	2.5	FALSE	FALSE	FALSE	FALSE	FALSE	FALSE	FALSE	FALSE
	Nois	FALSE	-77	-200	FALSE	FALSE	FALSE	FALSE	FALSE	FALSE	FALSE	FALSE
	FRQ20K	FALSE	4.5	1.5	FALSE	FALSE	FALSE	FALSE	FALSE	FALSE	FALSE	FALSE
	FRQ20	FALSE	5.5	2.5	FALSE	FALSE	FALSE	FALSE	FALSE	FALSE	FALSE	FALSE
	THDN	FALSE	0.015	0	FALSE	FALSE	FALSE	FALSE	FALSE	FALSE	FALSE	FALSE
5-4.(GV=+42dB)	AMPL	FALSE	5.5	2.5	FALSE	FALSE	FALSE	FALSE	FALSE	FALSE	FALSE	FALSE
	Nois	FALSE	-73	-200	FALSE	FALSE	FALSE	FALSE	FALSE	FALSE	FALSE	FALSE
	FRQ20K	FALSE	4.5	1.5	FALSE	FALSE	FALSE	FALSE	FALSE	FALSE	FALSE	FALSE
	FRQ20	FALSE	5.5	2.5	FALSE	FALSE	FALSE	FALSE	FALSE	FALSE	FALSE	FALSE
	THDN	FALSE	0.02	0	FALSE	FALSE	FALSE	FALSE	FALSE	FALSE	FALSE	FALSE
5-5.(GV=+48dB)	AMPL	FALSE	5.5	2.5	FALSE	FALSE	FALSE	FALSE	FALSE	FALSE	FALSE	FALSE
	Nois	FALSE	-68	-200	FALSE	FALSE	FALSE	FALSE	FALSE	FALSE	FALSE	FALSE
	FRQ20K	FALSE	3.5	1	FALSE	FALSE	FALSE	FALSE	FALSE	FALSE	FALSE	FALSE
	FRQ20	FALSE	5.5	2.5	FALSE	FALSE	FALSE	FALSE	FALSE	FALSE	FALSE	FALSE
	THDN	FALSE	0.02	0	FALSE	FALSE	FALSE	FALSE	FALSE	FALSE	FALSE	FALSE
5-6.(GV=+54dB)	AMPL	FALSE	5.5	2.5	FALSE	FALSE	FALSE	FALSE	FALSE	FALSE	FALSE	FALSE
	Nois	FALSE	-63	-200	FALSE	FALSE	FALSE	FALSE	FALSE	FALSE	FALSE	FALSE
	FRQ20K	FALSE	3.5	1	FALSE	FALSE	FALSE	FALSE	FALSE	FALSE	FALSE	FALSE
	FRQ20	FALSE	5.5	2.5	FALSE	FALSE	FALSE	FALSE	FALSE	FALSE	FALSE	FALSE
	THDN	FALSE	0.12	0	FALSE	FALSE	FALSE	FALSE	FALSE	FALSE	FALSE	FALSE
5-7.(GV=+64dB)	AMPL	FALSE	5.5	2.5	FALSE	FALSE	FALSE	FALSE	FALSE	FALSE	FALSE	FALSE
	Nois	FALSE	-52	-200	FALSE	FALSE	FALSE	FALSE	FALSE	FALSE	FALSE	FALSE
	FRQ20K	FALSE	3.5	1	FALSE	FALSE	FALSE	FALSE	FALSE	FALSE	FALSE	FALSE
	FRQ20	FALSE	5.5	2.5	FALSE	FALSE	FALSE	FALSE	FALSE	FALSE	FALSE	FALSE
	THDN	FALSE	0.12	0	FALSE	FALSE	FALSE	FALSE	FALSE	FALSE	FALSE	FALSE
5-8.OUT-10dBu (GV=+0dB)	AMPL	FALSE	-9	-11	FALSE	FALSE	FALSE	FALSE	FALSE	FALSE	FALSE	FALSE
	Nois	FALSE	-77	-200	FALSE	FALSE	FALSE	FALSE	FALSE	FALSE	FALSE	FALSE
	FRQ20K	FALSE	-8.5	-12	FALSE	FALSE	FALSE	FALSE	FALSE	FALSE	FALSE	FALSE
	FRQ20	FALSE	-8.5	-11.5	FALSE	FALSE	FALSE	FALSE	FALSE	FALSE	FALSE	FALSE
	THDN	FALSE	0.02	0	FALSE	FALSE	FALSE	FALSE	FALSE	FALSE	FALSE	FALSE
6.Phantom test	Pass/Fail	FALSE	Pass	FALSE	FALSE	FALSE	FALSE	FALSE	FALSE	FALSE	FALSE	
7.GIO test(Full)	%	FALSE	100	98	FALSE	FALSE	FALSE	FALSE	FALSE	FALSE	FALSE	
7.GIO test(Half)	%	FALSE	48	45	FALSE	FALSE	FALSE	FALSE	FALSE	FALSE	FALSE	

**Here is pass/fail result of each item.**

		Date diff	Time Diff
8.Time test	Value	100	100
9.LAN	Check		
10.RS232C	Check		
11.RS485	Check		

		Max	Min
8.Time test	Date diff	FALSE	0.1 -0.1
	Time Diff	FALSE	5 -5
9.LAN	Check	FALSE	Pass
10.RS232C	Check	FALSE	Pass
11.RS485	Check	FALSE	Pass

**Logged MAC address.**

MAC-ADDR	IP-ADDR

The example above shows a test that failed because of no data.

The method to load the log data is below.

- Open the Excel test file, “ESPTestReporter.xls”. Be sure to click ENABLE MACROS when the dialog box opens.
- Once the file is open, click on TOOLS / MACRO / MACROS. When the macro dialog box opens, you should see a macro named “TestLogOpen”. Select this macro and click RUN. When the File Open dialog box opens, browse to the location of the test text (.txt) file you created and select it. Click OPEN. At this point the test data will automatically be loaded into the Excel sheet.

If the item is passed, the corresponded cell will be changed to TRUE.

If the item is failed, the corresponded cell will be kept to FALSE.

After loading , pass/fail will be summed to the RESULT cell.

The macro will default to a blank sheet after the results have been loaded. You must open the .xls file that was created as a result of loading the test text (.txt) file. It will be the same name as the .txt file with an .xls extension. Once you open this file in Excel you will be able to view the results, PASS or FAIL, and view the parameters measured. All tests must be passed.

# TEST PROCEDURES

This is an example of the PASSED ESP-88 chassis test data in Excel format.

## AuBit

Device under test		According to OT1-400338	
Serial Number	ESP-1	Result	Passed
Lot			
Date of test	2005.03.13		
Tester's Name			

		CH1	CH2	CH3	CH4	CH5	CH6	CH7	CH8
5-1.(GV=0dB)	AMPL	4.17	4.02	3.94	4.11	3.92	3.94	4.00	3.95
	Nois	-80.03	-80.13	-80.05	-80.04	-81.30	-81.23	-81.30	-81.32
	FRQ20K	3.39	3.08	3.05	3.15	2.87	2.98	2.74	3.04
	FRQ20	3.66	3.50	3.41	3.61	3.44	3.47	3.54	3.48
	THDN	0.0067	0.0068	0.0076	0.0075	0.0068	0.0068	0.0067	0.0067
19.5dBu	0.0225	0.0223	0.0234	0.0214	0.0278	0.0265	0.0276	0.0278	
5-2.(GV=+14dB)	AMPL	3.94	3.76	3.68	3.89	3.68	3.72	3.75	3.71
	Nois	-79.97	-80.03	-80.06	-80.18	-81.24	-81.27	-81.23	-81.20
	FRQ20K	3.97	3.84	3.78	3.96	3.82	3.85	3.89	3.80
5-3.(GV=+24dB)	AMPL	3.97	3.84	3.78	3.96	3.82	3.85	3.89	3.80
	Nois	-79.91	-79.94	-79.79	-80.04	-81.16	-81.06	-81.11	-81.00
	FRQ20K	3.97	3.84	3.78	3.96	3.82	3.85	3.89	3.80
5-4.(GV=+42dB)	AMPL	4.17	4.02	3.85	4.05	4.20	4.24	4.02	3.95
	Nois	-75.36	-75.33	-75.65	-75.46	-75.77	-75.69	-75.95	-75.88
	FRQ20K	4.14	4.00	3.81	4.01	4.24	4.29	4.01	3.93
5-5.(GV=+48dB)	AMPL	-70.65	-70.71	-71.07	-70.96	-71.02	-70.78	-71.33	-71.17
	Nois	2.15	1.83	1.74	1.87	1.98	2.11	1.65	1.92
	FRQ20K	3.63	3.48	3.28	3.50	3.76	3.92	3.55	3.46
	THDN	0.0181	0.0180	0.0181	0.0185	0.0171	0.0174	0.0170	0.0173
	19.5dBu	0.0307	0.0298	0.0321	0.0298	0.0261	0.0244	0.0274	0.0262
5-6.(GV=+54dB)	AMPL	4.10	3.98	3.79	3.97	4.24	4.30	3.99	3.90
	Nois	-85.13	-85.21	-85.43	-85.32	-85.31	-85.18	-85.61	-85.55
	FRQ20K	3.95	3.82	3.63	3.80	4.07	4.13	3.82	3.74
5-7.(GV=+64dB)	AMPL	-55.36	-55.46	-55.81	-55.52	-55.53	-55.33	-55.90	-55.83
	Nois	1.9893	1.6630	1.5625	1.6647	1.8007	1.9400	1.4385	1.7218
	FRQ20K	3.5075	3.3655	3.1639	3.3625	3.6615	3.7238	3.4205	3.3315
	THDN	0.1047	0.1060	0.1036	0.1044	0.1003	0.1019	0.0990	0.1022
	19.5dBu	0.0302	0.0295	0.0294	0.0283	0.0294	0.0248	0.0255	0.0244
5-8.OUT-10dBu (GV=+0dB)	AMPL	-10.06	-10.17	-10.24	-10.09	-10.21	-10.19	-10.12	-10.15
	Nois	-87.79	-86.46	-86.29	-86.78	-95.11	-94.26	-94.19	-94.29
	FRQ20K	-10.6787	-10.9588	-10.9902	-10.8853	-11.1060	-10.9971	-11.2146	-10.8934
	THDN	-10.5730	-10.6629	-10.7810	-10.5954	-10.6889	-10.6588	-10.5831	-10.6263
	19.5dBu	0.0074	0.0085	0.0159	0.0151	0.0060	0.0074	0.0065	0.0063
6.Phantom test	Pass/Fail	Pass	Pass	Pass	Pass	Pass	Pass	Pass	Pass
7.GIO test(Full)	%	99.90	99.90	99.90	99.90	99.90	99.90	99.90	99.90
7.GIO test(Harf)	%	46.29	46.19	46.39	46.19	46.00	46.39	46.19	46.29

Total Result	TRUE
--------------	------

		Total	Max	Min	CH1	CH2	CH3	CH4	CH5	CH6	CH7	CH8
5-1.(GV=0dB)	AMPL	TRUE	5.5	2.5	TRUE	TRUE	TRUE	TRUE	TRUE	TRUE	TRUE	TRUE
	Nois	TRUE	-77	-200	TRUE	TRUE	TRUE	TRUE	TRUE	TRUE	TRUE	TRUE
	FRQ20K	TRUE	4.5	1.5	TRUE	TRUE	TRUE	TRUE	TRUE	TRUE	TRUE	TRUE
	FRQ20	TRUE	5.5	2.5	TRUE	TRUE	TRUE	TRUE	TRUE	TRUE	TRUE	TRUE
	THDN	TRUE	0.015	0	TRUE	TRUE	TRUE	TRUE	TRUE	TRUE	TRUE	TRUE
19.5dBu	TRUE	1.5	0	TRUE	TRUE	TRUE	TRUE	TRUE	TRUE	TRUE	TRUE	
5-2.(GV=+14dB)	AMPL	TRUE	5.5	2.5	TRUE	TRUE	TRUE	TRUE	TRUE	TRUE	TRUE	TRUE
	Nois	TRUE	-77	-200	TRUE	TRUE	TRUE	TRUE	TRUE	TRUE	TRUE	TRUE
	FRQ20K	TRUE	5.5	2.5	TRUE	TRUE	TRUE	TRUE	TRUE	TRUE	TRUE	TRUE
5-3.(GV=+24dB)	AMPL	TRUE	5.5	2.5	TRUE	TRUE	TRUE	TRUE	TRUE	TRUE	TRUE	TRUE
	Nois	TRUE	-77	-200	TRUE	TRUE	TRUE	TRUE	TRUE	TRUE	TRUE	TRUE
	FRQ20K	TRUE	5.5	2.5	TRUE	TRUE	TRUE	TRUE	TRUE	TRUE	TRUE	TRUE
5-4.(GV=+42dB)	AMPL	TRUE	5.5	2.5	TRUE	TRUE	TRUE	TRUE	TRUE	TRUE	TRUE	TRUE
	Nois	TRUE	-73	-200	TRUE	TRUE	TRUE	TRUE	TRUE	TRUE	TRUE	TRUE
	FRQ20K	TRUE	5.5	2.5	TRUE	TRUE	TRUE	TRUE	TRUE	TRUE	TRUE	TRUE
5-5.(GV=+48dB)	AMPL	TRUE	5.5	2.5	TRUE	TRUE	TRUE	TRUE	TRUE	TRUE	TRUE	TRUE
	Nois	TRUE	-68	-200	TRUE	TRUE	TRUE	TRUE	TRUE	TRUE	TRUE	TRUE
	FRQ20K	TRUE	3.5	1.5	TRUE	TRUE	TRUE	TRUE	TRUE	TRUE	TRUE	TRUE
	FRQ20	TRUE	5.5	2.5	TRUE	TRUE	TRUE	TRUE	TRUE	TRUE	TRUE	TRUE
	THDN	TRUE	0.02	0	TRUE	TRUE	TRUE	TRUE	TRUE	TRUE	TRUE	TRUE
19.5dBu	TRUE	1.5	0	TRUE	TRUE	TRUE	TRUE	TRUE	TRUE	TRUE	TRUE	
5-6.(GV=+54dB)	AMPL	TRUE	5.5	2.5	TRUE	TRUE	TRUE	TRUE	TRUE	TRUE	TRUE	TRUE
	Nois	TRUE	-63	-200	TRUE	TRUE	TRUE	TRUE	TRUE	TRUE	TRUE	TRUE
	FRQ20K	TRUE	5.5	2.5	TRUE	TRUE	TRUE	TRUE	TRUE	TRUE	TRUE	TRUE
5-7.(GV=+64dB)	AMPL	TRUE	5.5	2.5	TRUE	TRUE	TRUE	TRUE	TRUE	TRUE	TRUE	TRUE
	Nois	TRUE	-52	-200	TRUE	TRUE	TRUE	TRUE	TRUE	TRUE	TRUE	TRUE
	FRQ20K	TRUE	3.5	1	TRUE	TRUE	TRUE	TRUE	TRUE	TRUE	TRUE	TRUE
	FRQ20	TRUE	5.5	2.5	TRUE	TRUE	TRUE	TRUE	TRUE	TRUE	TRUE	TRUE
	THDN	TRUE	0.12	0	TRUE	TRUE	TRUE	TRUE	TRUE	TRUE	TRUE	TRUE
19.5dBu	TRUE	1.5	0	TRUE	TRUE	TRUE	TRUE	TRUE	TRUE	TRUE	TRUE	
5-8.OUT-10dBu (GV=+0dB)	AMPL	TRUE	-9	-11	TRUE	TRUE	TRUE	TRUE	TRUE	TRUE	TRUE	TRUE
	Nois	TRUE	-77	-200	TRUE	TRUE	TRUE	TRUE	TRUE	TRUE	TRUE	TRUE
	FRQ20K	TRUE	-8.5	-11.5	TRUE	TRUE	TRUE	TRUE	TRUE	TRUE	TRUE	TRUE
	FRQ20	TRUE	-8.5	-11.5	TRUE	TRUE	TRUE	TRUE	TRUE	TRUE	TRUE	TRUE
	THDN	TRUE	0.02	0	TRUE	TRUE	TRUE	TRUE	TRUE	TRUE	TRUE	TRUE
19.5dBu	TRUE	1.5	0	TRUE	TRUE	TRUE	TRUE	TRUE	TRUE	TRUE	TRUE	
6.Phantom test	Pass/Fail	TRUE	Pass	TRUE	TRUE	TRUE	TRUE	TRUE	TRUE	TRUE	TRUE	TRUE
7.GIO test(Full)	%	TRUE	100	98	TRUE	TRUE	TRUE	TRUE	TRUE	TRUE	TRUE	TRUE
7.GIO test(Harf)	%	TRUE	48	45	TRUE	TRUE	TRUE	TRUE	TRUE	TRUE	TRUE	TRUE

		Date diff	Time Diff
8.Time test	Value	0	1
9.LAN	Check	Pass	
10.RS232C	Check	Pass	
11.RS485	Check	Pass	

		Max	Min
8.Time test	Date diff	TRUE	0.1
	Time Diff	TRUE	-5
9.LAN	Check	TRUE	Pass
10.RS232C	Check	TRUE	Pass
11.RS485	Check	TRUE	Pass

### 5. Testing method and criteria.

**Note:** The information in the following pages is provided for reference only. You will not need to set the ATS2 manually to perform these tests.

This section describes the settings and criteria of each of the tests to be performed. The setting of the ATS-2 test station will be done automatically by the ATS2 Macro.

#### 5-1. Gain at 0dB

ESP Setting: Set all channel gains to = 0dB. (Command on COM = ^BA{1/2}{L/R}00^C)

AMPL(1kHz)  
ATS2 Settings

Item	Setting
Frequency	1kHz
Amplitude	+4.00dBu
B/W	<10HZ / FS/2
Filter	None

Test Limits

Item	Upper limit	Lower limit
Level	+5.5dBu	+2.5dBu

# TEST PROCEDURES

Noise Test  
ATS2 Settings

Item	Setting
Frequency	--
Amplitude	Off
B/W	22HZ / 22KHz LPF
Filter	"A" Weighting

Test Limits

Item	Upper limit	Lower limit
Level	-77dBu	-200dBu

FRQ20kHz  
ATS2 Settings

Item	Setting
Frequency	20kHz
Amplitude	+4.00dBu
B/W	<10HZ / FS/2
Filter	None

Test Limits

Item	Upper limit	Lower limit
Level	+4.5dBu	+1.5dBu

FRQ20Hz  
ATS2 Settings

Item	Setting
Frequency	20Hz
Amplitude	+4.00dBu
B/W	<10HZ / FS/2
Filter	None

Test Limits

Item	Upper limit	Lower limit
Level	+5.5dBu	+2.5dBu

THDN  
ATS2 Settings

Item	Setting
Frequency	1kHz
Amplitude	+4.00dBu
B/W	22HZ / 22KHz LPF
Filter	"A" Weighting

Test Limits

Item	Upper limit	Lower limit
Function(THD+N)	0.015%	0

# TEST PROCEDURES

19.5dBu  
ATS2 Settings

Item	Setting
Frequency	1kHz
Amplitude	+23.5dBu (Nominal +19.5dB)
B/W	22HZ / 22KHz LPF
Filter	"A" Weighting

Test Limits

Item	Upper limit	Lower limit
Function(THD+N)	1.5%	0

Perform these tests for channels 1 through 8.

5-2.Gain at 14dB

ESP Setting: Set all channel gains to = 14dB.

(Command on COM = ^BA{1/2}{L/R}14^C)

AMPL(1kHz)  
ATS2 Settings

Item	Setting
Frequency	1kHz
Amplitude	-10.00dBu
B/W	<10HZ / FS/2
Filter	None

Test Limits

Item	Upper limit	Lower limit
Level	+5.5dBu	+2.5dBu

Noise  
ATS2 Settings

Item	Setting
Frequency	--
Amplitude	Off
B/W	22HZ / 22KHz LPF
Filter	"A" Weighting

Test Limits

Item	Upper limit	Lower limit
Level	-77dBu	-200dBu

Perform this test on channels 1 through 8.

# TEST PROCEDURES

## 5-3.Gain 24dB

ESP-88 Chassis Settings: Set all channel gains to = 24dB.

(Command on COM = ^BA{1/2}{L/R}24^C)

AMPL(1kHz)

ATS2 Settings

Item	Setting
Frequency	1kHz
Amplitude	-20.00dBu
B/W	<10HZ / FS/2
Filter	None

Test Limits

Item	Upper limit	Lower limit
Level	+5.5dBu	+2.5dBu

Noise

ATS2 Settings

Item	Setting
Frequency	--
Amplitude	Off
B/W	22HZ / 22KHz LPF
Filter	"A" Weighting

Test Limits

Item	Upper limit	Lower limit
Level	-77dBu	-200dBu

Perform this test on channels 1 through 8.

## 5-4.Gain 42dB

ESP Settings: Set all channel gains to = 42dB.

(Command on COM = ^BA{1/2}{L/R}42^C)

AMPL(1kHz)

ATS2 Settings

Item	Setting
Frequency	1kHz
Amplitude	-38.00dBu
B/W	<10HZ / FS/2
Filter	None

Test Limits

Item	Upper limit	Lower limit
Level	+5.5dBu	+2.5dBu



# TEST PROCEDURES

Noise

ATS2 Settings

Item	Setting
Frequency	--
Amplitude	Off
B/W	22HZ / 22KHz LPF
Filter	"A" Weighting

Test Limits

Item	Upper limit	Lower limit
Level	-73dBu	-200dBu

Perform this test on channels 1 through 8.

5-5. Gain 48dB

ESP Settings: Set all channel gains to = 48dB.

(Command on COM = ^BA{1/2}{L/R}48^C)

AMPL(1kHz)

ATS2 Settings

Item	Setting
Frequency	1kHz
Amplitude	-44.00dBu
B/W	<10HZ / FS/2
Filter	None

Test Limits

Item	Upper limit	Lower limit
Level	+5.5dBu	+2.5dBu

Noise

ATS2 Settings

Item	Setting
Frequency	--
Amplitude	Off
B/W	22HZ / 22KHz LPF
Filter	"A" Weighting

Test Limits

Item	Upper limit	Lower limit
Level	-68dBu	-200dBu

# TEST PROCEDURES

FRQ20kHz  
ATS2 Settings

Item	Setting
Frequency	20kHz
Amplitude	-44.00dBu
B/W	<10HZ / FS/2
Filter	None

Test Limits

Item	Upper limit	Lower limit
Level	+3.5dBu	+1.0dBu

FRQ20Hz  
ATS2 Settings

Item	Setting
Frequency	20Hz
Amplitude	-44.00dBu
B/W	<10HZ / FS/2
Filter	None

Test Limits

Item	Upper limit	Lower limit
Level	+5.5dBu	+2.5dBu

THDN  
ATS2 Settings

Item	Setting
Frequency	1kHz
Amplitude	-44.00dBu
B/W	22HZ / 22KHz LPF
Filter	"A" Weighting

Test Limits

Item	Upper limit	Lower limit
Function(THD+N)	0.02%	0

19.5dBu  
ATS2 Settings

Item	Setting
Frequency	1kHz
Amplitude	-24.5dBu (Nominal +19.5dB)
B/W	22HZ / 22KHz LPF
Filter	"A" Weighting

Test Limits

Item	Upper limit	Lower limit
Function(THD+N)	1.5%	0

Perform this test on channels 1 through 8.

# TEST PROCEDURES

## 5-6.Gain 54dB

ESP Setting: Set all channel gains to = 54dB.

(Command on COM = ^BA{1/2}{L/R}54^C)

AMPL(1kHz)

ATS2 Settings

Item	Setting
Frequency	1kHz
Amplitude	-50.00dBu
B/W	<10HZ / FS/2
Filter	None

Test Limits

Item	Upper limit	Lower limit
Level	+5.5dBu	+2.5dBu

Noise

ATS2 Settings

Item	Setting
Frequency	--
Amplitude	Off
B/W	22HZ / 22KHz LPF
Filter	"A" Weighting

Test Limits

Item	Upper limit	Lower limit
Level	-63dBu	-200dBu

Perform this test on channels 1 through 8.

## 5-7.Gain 64dB

ESP Setting: Set all channel gains to = 64dB.

(Command on COM = ^BA{1/2}{L/R}64^C)

AMPL(1kHz)

ATS2 Settings

Item	Setting
Frequency	1kHz
Amplitude	-60.00dBu
B/W	<10HZ / FS/2
Filter	None

Test Limits

Item	Upper limit	Lower limit
Level	+5.5dBu	+2.5dBu

# TEST PROCEDURES

Noise

ATS2 Settings

Item	Setting
Frequency	--
Amplitude	Off
B/W	22HZ / 22KHz LPF
Filter	"A" Weighting

Test Limits

Item	Upper limit	Lower limit
Level	-52dBu	-200dBu

FRQ20kHz

ATS2 Settings

Item	Setting
Frequency	20kHz
Amplitude	-60.00dBu
B/W	<10HZ / FS/2
Filter	None

Test Limits

Item	Upper limit	Lower limit
Level	+3.5dBu	+1.0dBu

FRQ20Hz

ATS2 Settings

Item	Setting
Frequency	20Hz
Amplitude	-60.00dBu
B/W	<10HZ / FS/2
Filter	None

Test Limits

Item	Upper limit	Lower limit
Level	+5.5dBu	+2.5dBu

THDN

ATS2 Settings

Item	Setting
Frequency	1kHz
Amplitude	-60.00dBu
B/W	22HZ / 22KHz LPF
Filter	"A" Weighting

Test Limits

Item	Upper limit	Lower limit
Function(THD+N)	0.12%	0

# TEST PROCEDURES

19.5dBu  
ATS2 Settings

Item	Setting
Frequency	1kHz
Amplitude	-40.5 dBu (Nominal +19.5dB)
B/W	22HZ / 22KHz LPF
Filter	"A" Weighting

Test Limits

Item	Upper limit	Lower limit
Function(THD+N)	1.5%	0

Perform this test on channels 1 through 8.

5-8.Gain 0dB and Output Level -10dB

ESP Setting: Set all channel gains to = 0dB. (Command on COM = ^BA{1/2}{L/R}00^C)

ESP Setting: Set all channel output levels to = -10dB. (Command on COM = ^BL{1/2}{L/R}0^C)

AMPL(1kHz)  
ATS2 Settings

Item	Setting
Frequency	1kHz
Amplitude	+4.00dBu
B/W	<10HZ / FS/2
Filter	None

Test Limits

Item	Upper limit	Lower limit
Level	-9.0dBu	-11.0dBu

Noise  
ATS2 Settings

Item	Setting
Frequency	--
Amplitude	Off
B/W	22HZ / 22KHz LPF
Filter	"A" Weighting

Test Limits

Item	Upper limit	Lower limit
Level	-77dBu	-200dBu



# TEST PROCEDURES

FRQ20kHz  
ATS2 Settings

Item	Setting
Frequency	20kHz
Amplitude	+4.00dBu
B/W	<10HZ / FS/2
Filter	None

Test Limits

Item	Upper limit	Lower limit
Level	-8.5dBu	-11.5dBu

FRQ20Hz  
ATS2 Settings

Item	Setting
Frequency	20Hz
Amplitude	+4.00dBu
B/W	<10HZ / FS/2
Filter	None

Test Limits

Item	Upper limit	Lower limit
Level	-8.5dBu	-11.5dBu

THDN  
ATS2 Settings

Item	Setting
Frequency	1kHz
Amplitude	+4.00dBu
B/W	22HZ / 22KHz LPF
Filter	"A" Weighting

Test Limits

Item	Upper limit	Lower limit
Function(THD+N)	0.02%	0

19.5dBu  
ATS2 Settings

Item	Setting
Frequency	1kHz
Amplitude	+23.5dBu (Nominal +19.5dB)
B/W	22HZ / 22KHz LPF
Filter	"A" Weighting

Test Limits

Item	Upper limit	Lower limit
Function(THD+N)	1.5%	0

Perform this test on channels 1 through 8.

# TEST PROCEDURES

## 6. Phantom test

The phantom test will be done after the audio tests.

Pass/Fail is detected by "Phantom Checker".

This phantom checker is modified a GIO used to measure the voltage of the phantom power.

### Test Limits

Item	Pass	Fail
Hot and Cold line (CH 1/2/3/4)	Measured channel More than 13V	Measured channel Lower than 13V
	Opposite channel Lower than 2V	Opposite channel More than 2V

Perform these tests for channels 1 through 4.

Refer to section "4-7. About Phantomtest on ATS2".

## 7. GIO test.

This GIO test will be done by the ATS2 macro automatically.

This test requires the GIO 2.2k ohm loop back cable.

The GIO settings are as follows.

ESP Setting: Set GIO outputs.

(Command on COM = ^BO{0~7}{0/1}^C)

ESP Setting: Get the value of GIO input .

(Command on COM = ^BI^C)

### Test Limits

Item	Upper limit	Lower limit
GIO test (Full)	100%	95%
GIO test (Half)	48%	45%

Perform this test for ports 0 through 7.

## 8. Time test.

This time test will be done by the ATS2 macro automatically.

In this test, the time that is stored on the ESP is compared with the PC time by the ATS2 macro.

ESP Setting : Get time report from ESP.

(Command on COM = t )

### Test Limits

Item	Upper limit	Lower limit
Date diff	0	0
Time diff	+3	-3

# TEST PROCEDURES

## 9. LAN Test.

The configuration of ESP is done by the Local Area Network (LAN).

Therefore LAN communication can be confirmed by the ESP and can be settled by the design tool and that can measure it in the correct situation.

Test Limits

Item	Pass	Fail
LAN	ATS2 macro can reach this item.	Cannot reach.

## 10. RS-232C Test.

The measurement by ATS2 macro is done using the RS232C line.

Therefore RS232C communication can be confirmed by the ESP and it can be measured in the correct situation.

Test Limits

Item	Pass	Fail
RS232C	ATS2 macro can reach this item.	Can not reach.

## 11. RS-485 Test.

This RS-485 test will come after above inspection.

Pass/Fail is detected by automatically.

Refer to section "4-8. About RS485 test on ATS2".

When "EC16" could be found in the sequence of ESP setting(refer to section 4), this test is passed.

Test Limits

Item	Pass	Fail
RS485	"EC16" could be found in design tool.	Can not found.

## 12. Phantom Power Test

The test will prompt you to check to see if the A or B red LEDs on the phantom cutter PCB are lit or not. Respond to the prompts as needed. If the LEDs are lit properly for all 8 channels, the test will be completed.

## 13. Test Completion.

Once all of the tests are completed, the dialog box shown below will appear.

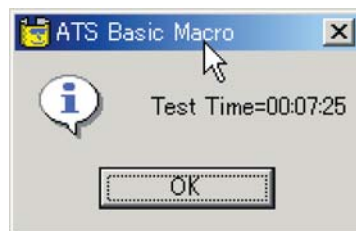

Click the OK button to end the test. You will get the dialog box shown above. Click OK.

# TEST PROCEDURES

Once the test is complete, open the ControlSpace™ software and set the ESP-88 chassis so that there is no connection, as shown in the examples below. This must be done so that the chassis will not be configured for pass-through when it gets back to the customer.

Setting of outside of ESP

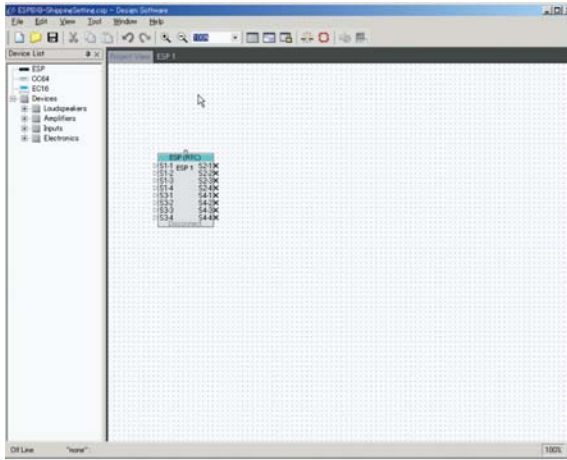

No connection

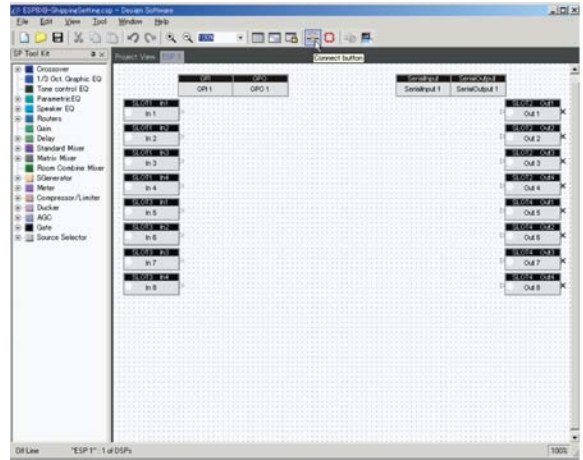

Write no connection by “connecting”. And disconnect.

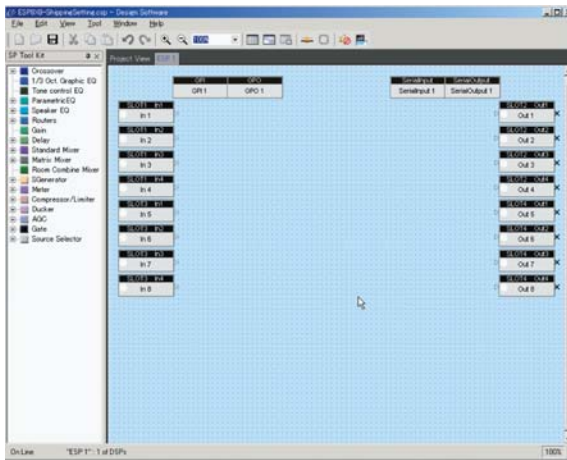

Push ok button on ATS Basic Macro dialog.  
Then return to first dialog, choose finish or continue.

# TEST PROCEDURES

13. Viewing the test results.

The log data that was obtained by the ATS2 macro must be evaluated by opening the Excel sheet that was described in section “4-10. Pass/Fail evaluation and report of this test.”

## AuBit

Device under test	
Serial Number	ESP-1
Lot	
Date of test	2005,03,13
Tester's Name	

According to OT1-400338

Result **Passed**

	CH1	CH2	CH3	CH4	CH5	CH6	CH7	CH8	
5-1.(GV=0dB)	AMPL	4.17	4.02	3.94	4.11	3.92	3.94	4.00	3.95
	Nois	-80.03	-80.13	-80.05	-80.04	-81.30	-81.23	-81.30	-81.32
	FRQ20K	3.39	3.08	3.05	3.15	2.87	2.98	2.74	3.04
	FRQ20	3.66	3.50	3.41	3.61	3.44	3.47	3.54	3.48

When this sheet shows that the unit has passed test, it can be returned to the customer.

If the test is failed, retest or repair the ESP.

## AuBit

Device under test	
Serial Number	
Lot	
Date of test	
Tester's Name	

According to OT1-400338

Result **FAIL**

	CH1	CH2	CH3	CH4	CH5	CH6	CH7	CH8
5-1.(GV=0dB)	AMPL							
	Nois							
	FRQ20K							
	FRQ20							

Print out the results of the Excel sheet and place it with the unit to be shipped back to the customer. The passed Excel test sheet and text (.txt) log file should be archived so that there is a record of the unit passing test.



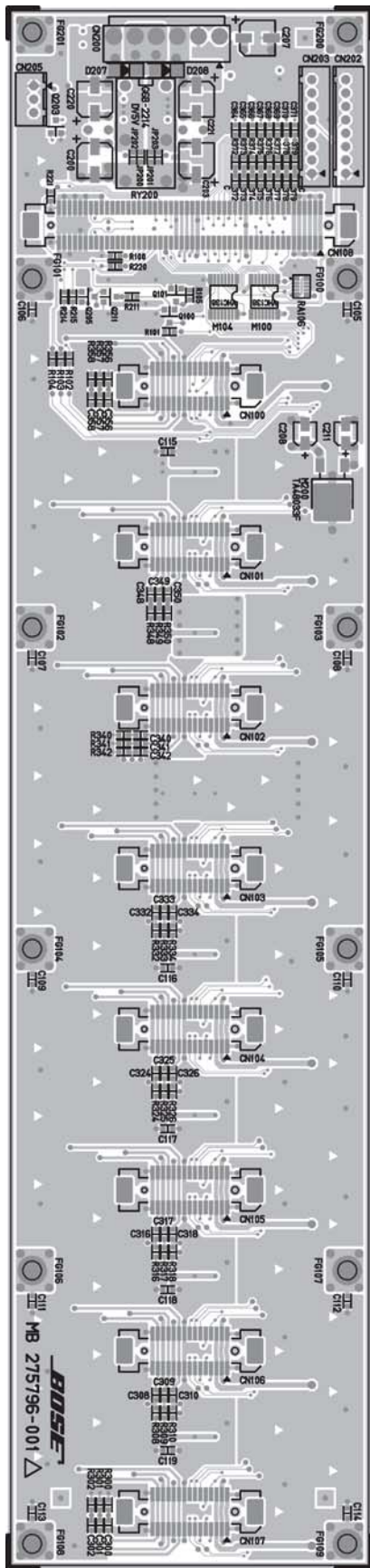

Figure 8. Motherboard Top Etch Layout Diagram

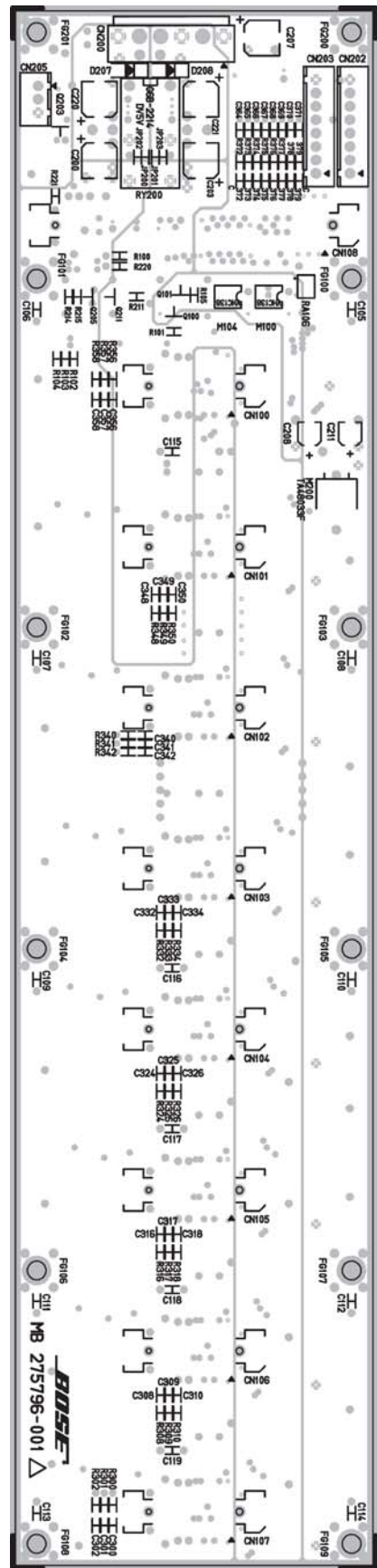

Figure 9. Motherboard VCC Etch Layout Diagram

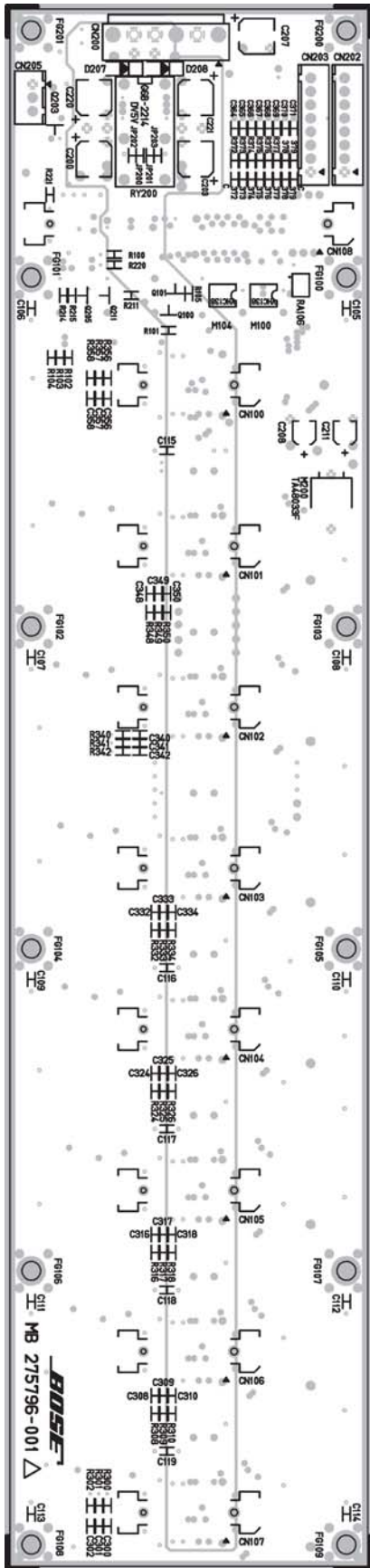

Figure 10. Motherboard GND Etch Layout Diagram

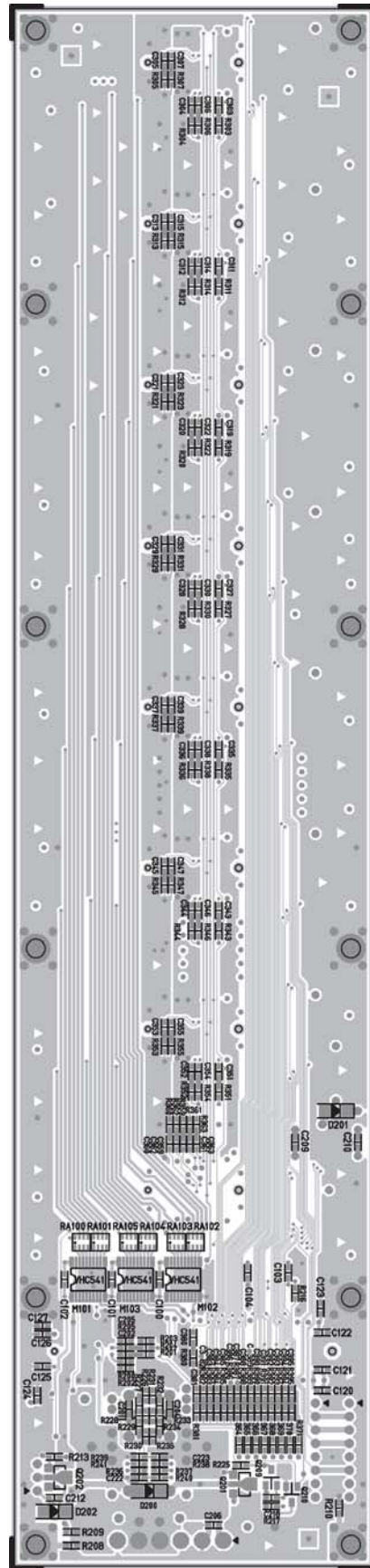

Figure 11. Motherboard Bottom Etch Layout Diagram

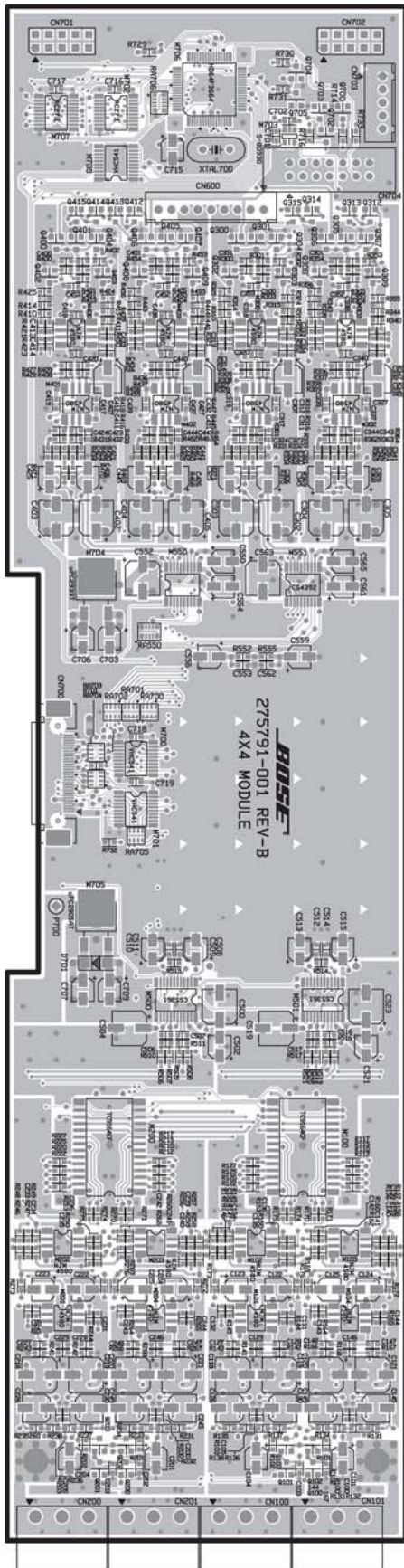

Figure 12. MIC/Line Input PCB Topside Etch Layout Diagram

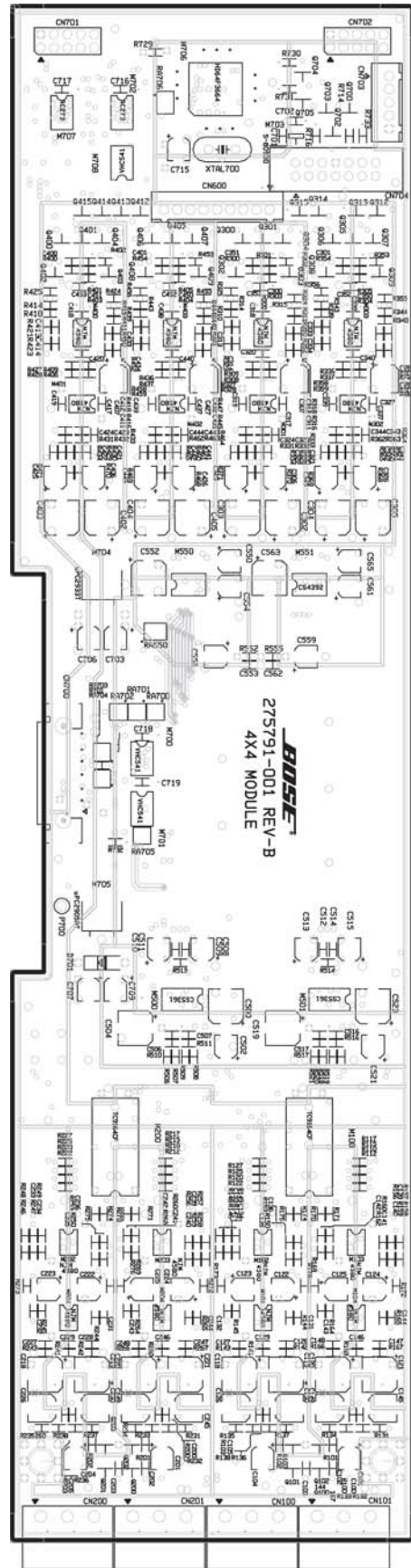

Figure 13. MIC/Line Input PCB VCC Etch Layout Diagram





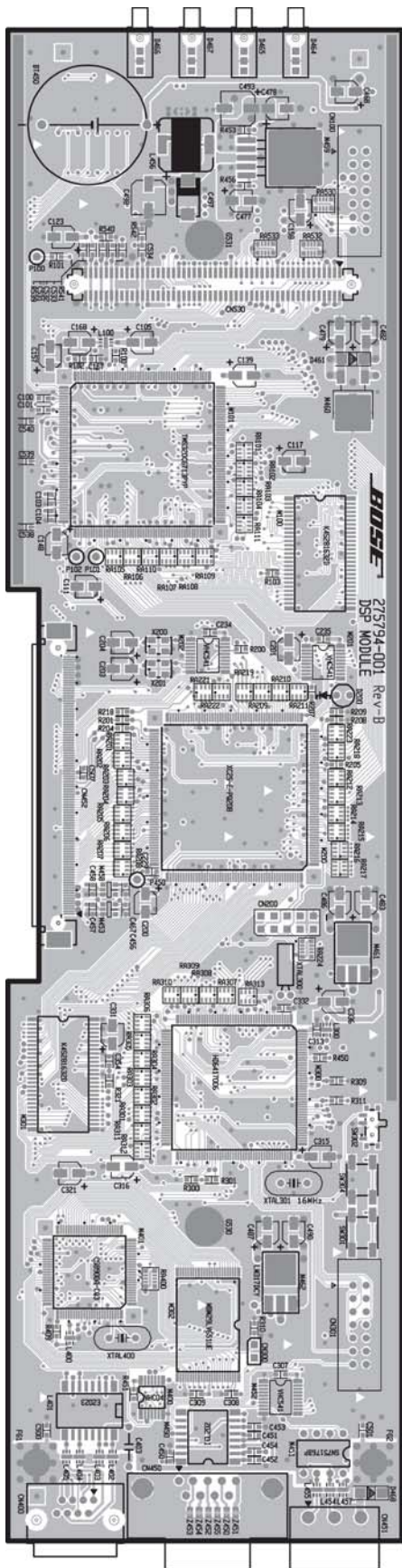

Figure 16. DSP PCB Topside Etch Layout Diagram

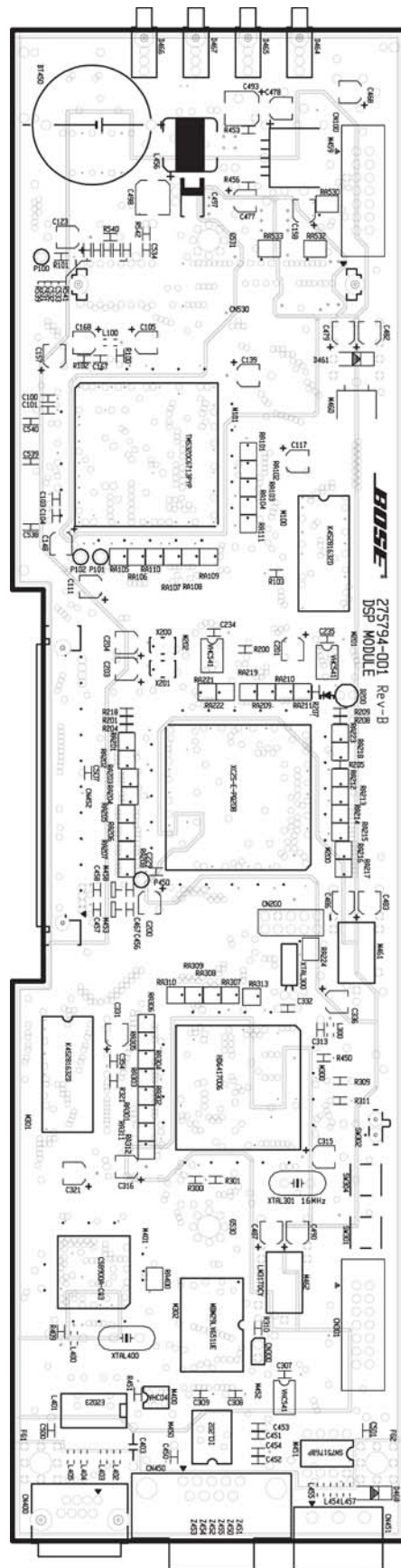

Figure 17. DSP PCB VCC Etch Layout Diagram



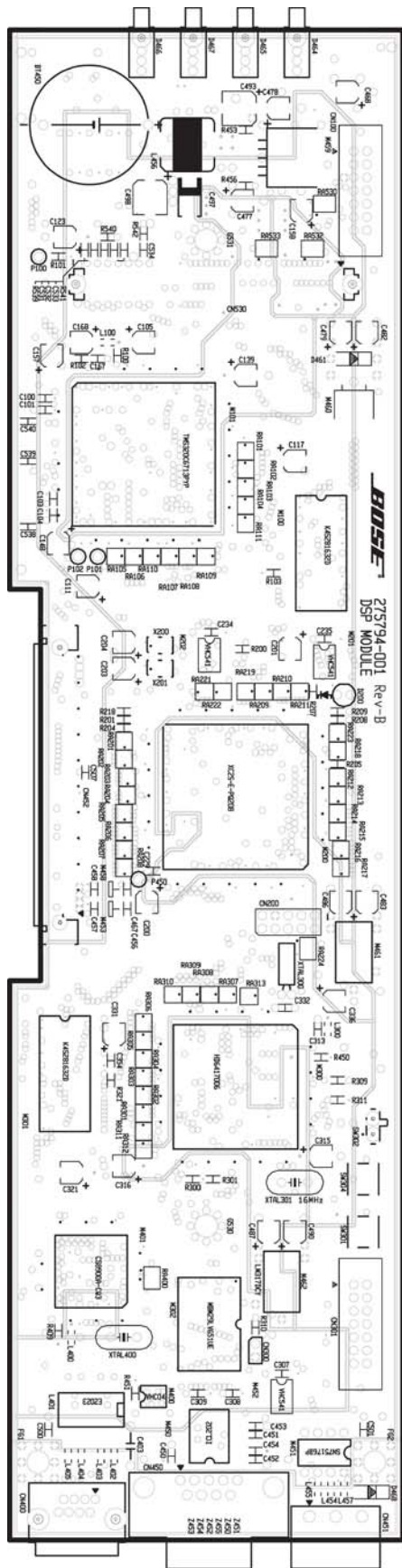

Figure 18. DSP PCB GND Etch Layout Diagram

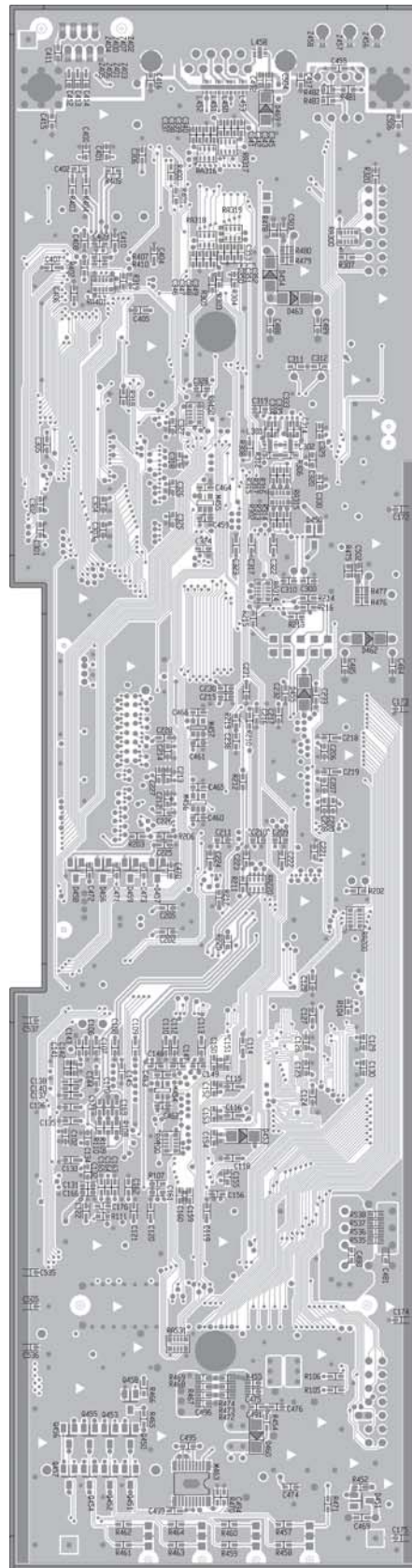

Figure 19. DSP PCB Bottom Etch Layout Diagram

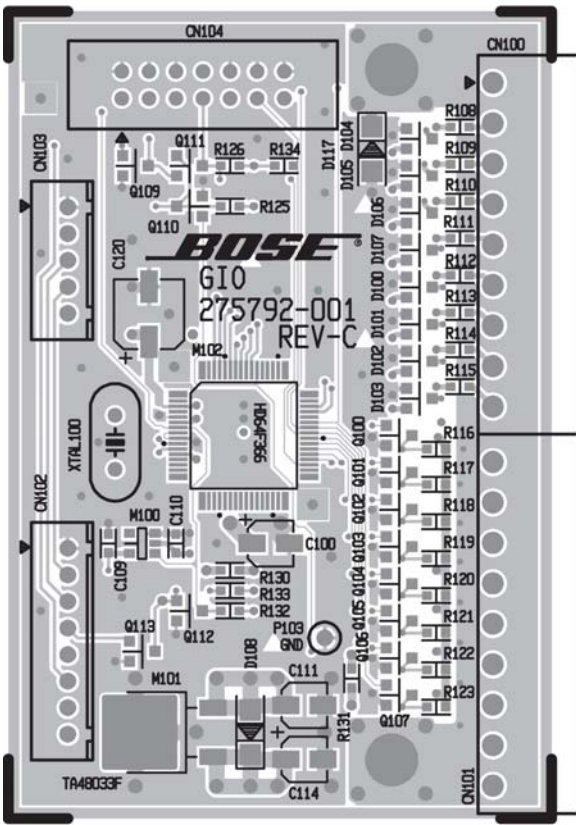

Figure 20. GPIO PCB Topside Etch Layout Diagram

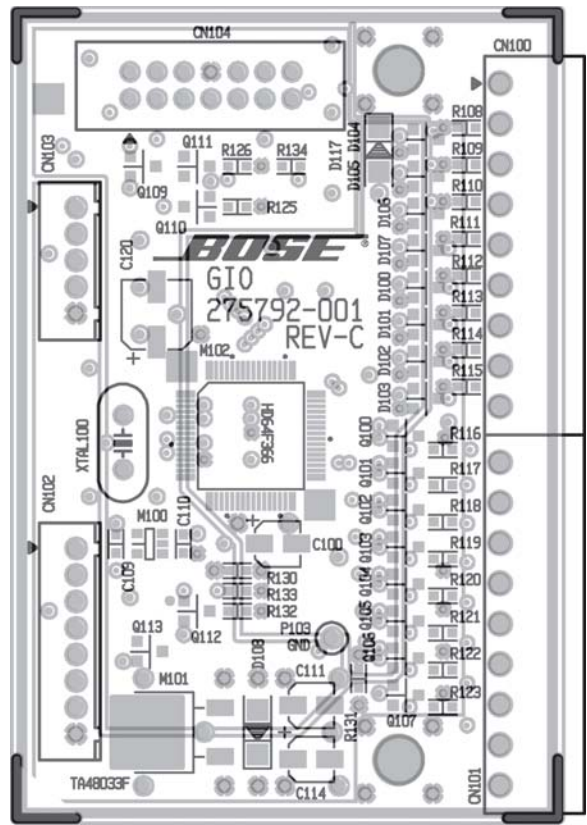

Figure 21. GPIO PCB VCC Etch Layout Diagram

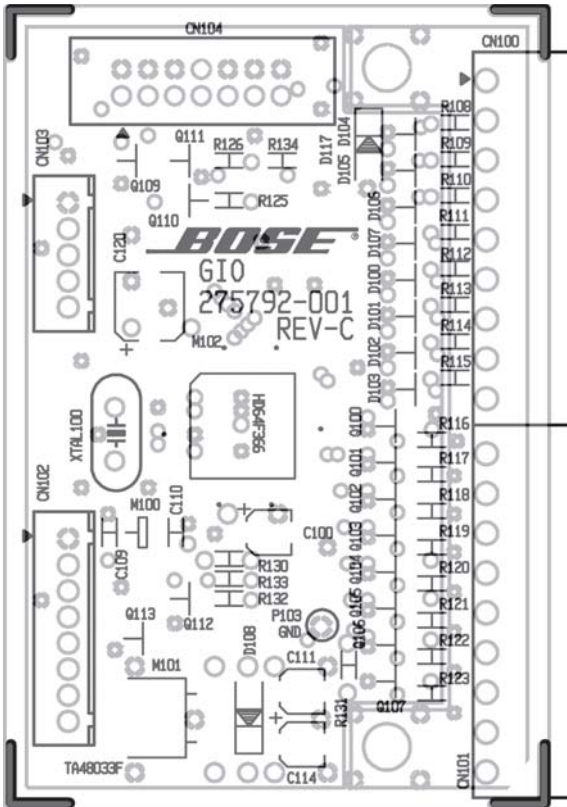

Figure 22. GPIO PCB GND Etch Layout Diagram

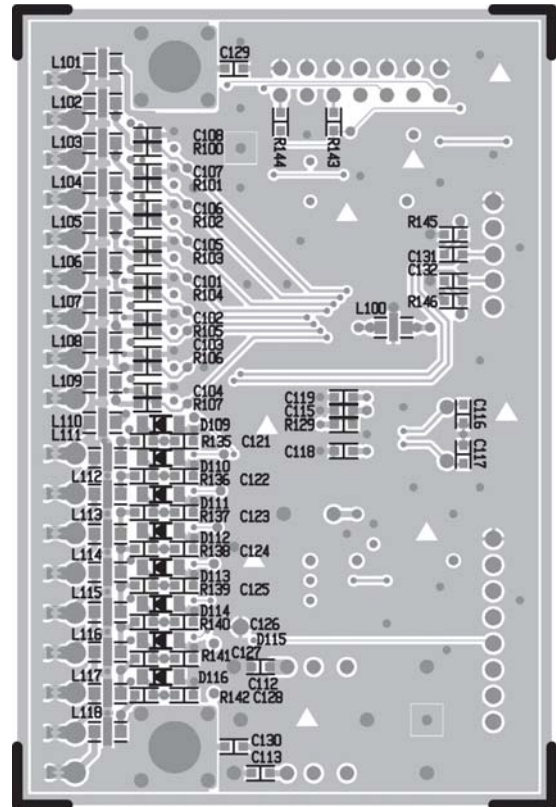

Figure 23. GPIO PCB Bottom Etch Layout Diagram

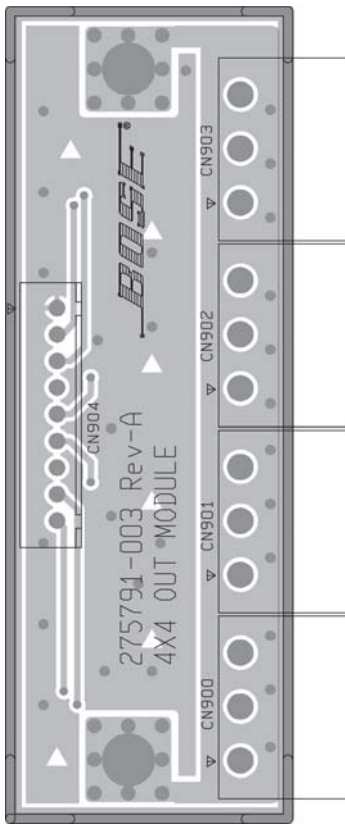

Figure 24. Output PCB Topside Etch Layout Diagram

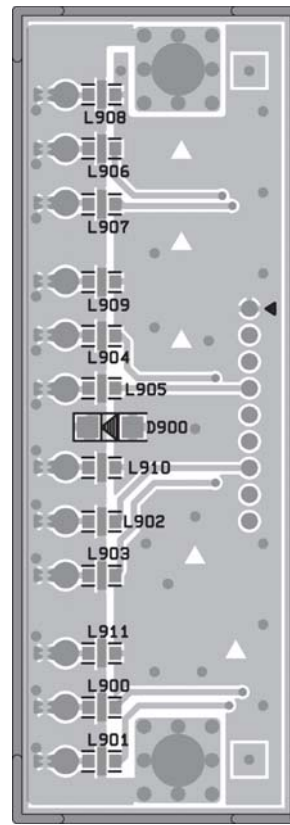

Figure 25. Output PCB Bottom Etch Layout Diagram

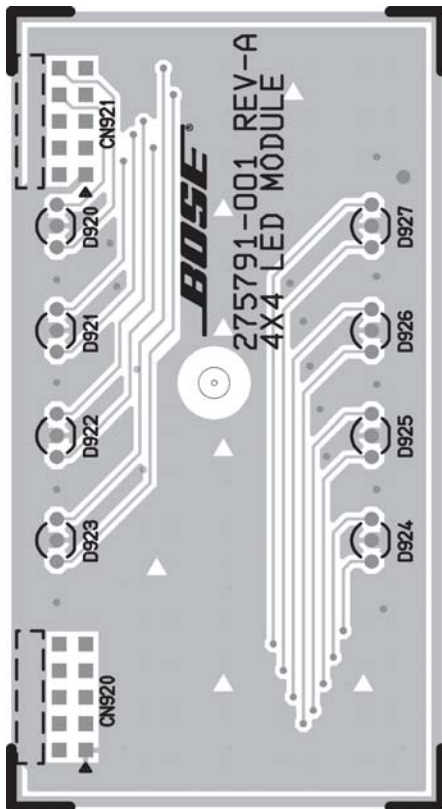

Figure 26. LED PCB Topside Etch Layout Diagram

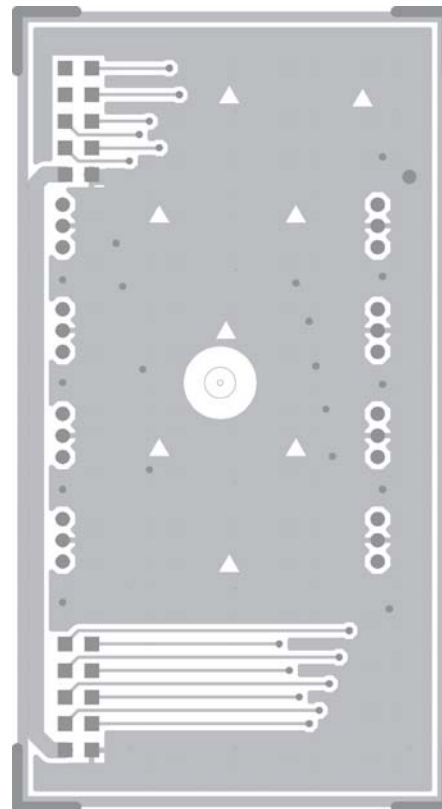

Figure 27. LED PCB Bottom Etch Layout Diagram



# DC Power Supply +5V Adjustment Procedures

## Integrated Power Devices (IPD) Power Supply +5VDC Voltage Adjustment Procedure

**CAUTION:** Dangerous voltages are present when the chassis is powered up and the top cover is off. Use care when performing the below procedure.

**Note:** This procedure is to be performed on ESP-88 / ESP-88C chassis using the IPD power supply only. The power supply is labeled with the name of the manufacturer on the side of the supply.

**Note:** The IPD power supply is set to +5Vdc at the factory. The ESP-88 and ESP-88C chassis requires +5.2Vdc to operate properly. Measure the DC voltage level using the following procedure. Adjust the 5 volt level if needed.

1. Remove the chassis top cover. Check to see if the chassis is using the original wiring harness. The original wiring harness uses a translucent body connector at the DC power supply end. The upgraded harnesses use a solid white connector. The examples shown at right are for units with the IPD supply.

If the wiring harness connector has a translucent plastic body, unplug it from the power supply and motherboard and discard it. Install the upgraded harness Bose® part number 318938-001S.

**Note:** The wiring harnesses for the IPD and Astec supplies are NOT interchangeable. They have different wiring connections. Be sure to use the correct harness for your chassis.

2. With the top cover removed and AC mains voltage applied, measure the +5Vdc level at the DC output connector on the power supply. Place the positive (+) probe on the red wire at the pin 1 location. Place the negative (-) probe on the black wire at the pin 2 location.

If the DC voltage level reads less than +5.2Vdc, adjust the +5 Volt potentiometer clockwise until the meter reads +5.2Vdc.

3. Turn off AC mains to the chassis.

4. Replace the top cover.

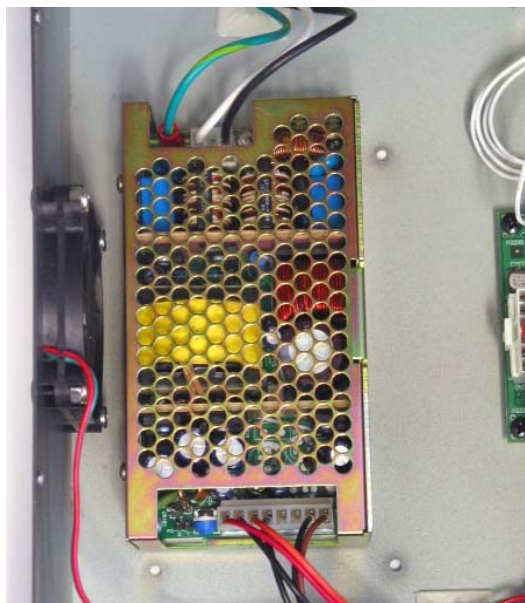

Astec Power Supply

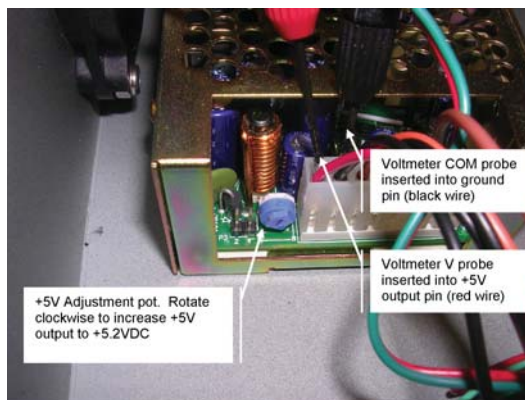
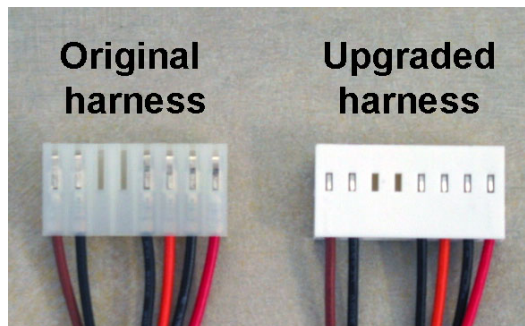

# DC Power Supply +5V Adjustment Procedures

## Astec Power Supply +5VDC Voltage Adjustment Procedure

**CAUTION:** Dangerous voltages are present when the chassis is powered up and the top cover is off. Use care when performing the below procedure.

**Note:** This procedure is to be performed on ESP-88C and ESP-00 chassis using the Astec power supply only. The Astec power supply uses a silver color cage. Refer to the photo at right.

The Astec power supply is set to +5Vdc at the factory. The ESP-88C and ESP-00 chassis require +5.2Vdc to operate properly. Measure the DC voltage level using the following procedure. Adjust the 5 volt level if needed.

1. Remove the chassis top cover. Check to see if the chassis is using the original wiring harness. The original wiring harness uses a translucent body connector at the DC power supply end. The upgraded harnesses use a solid white connector. The examples shown at right are for units with the IPD supply.

If the wiring harness connector has a translucent plastic body, unplug it from the power supply and motherboard and discard it. Install the upgraded harness Bose® part number 318935-001S.

**Note:** The wiring harnesses for the IPD and Astec supplies are NOT interchangeable. They have different wiring connections. Be sure to use the correct harness for your chassis.

Remove the four screws located on the sides of the power supply that secure the top half of the power supply cage. Lift off the cage top.

2. With AC mains voltage applied, measure the +5Vdc level at the DC output connector on the power supply. Place the positive (+) probe on the red wire at the pin 2 location. Place the negative (-) probe on the black wire at the pin 3 location.

3. If the DC voltage level reads less than +5.2Vdc, adjust the +5 Volt potentiometer clockwise until the meter reads +5.2Vdc.

4. Turn off AC mains to the chassis.

5. Re-assemble the power supply and replace the chassis top cover.

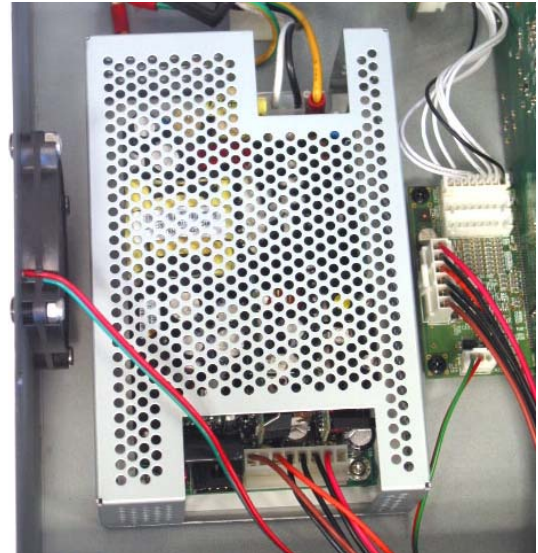

IPD Power Supply

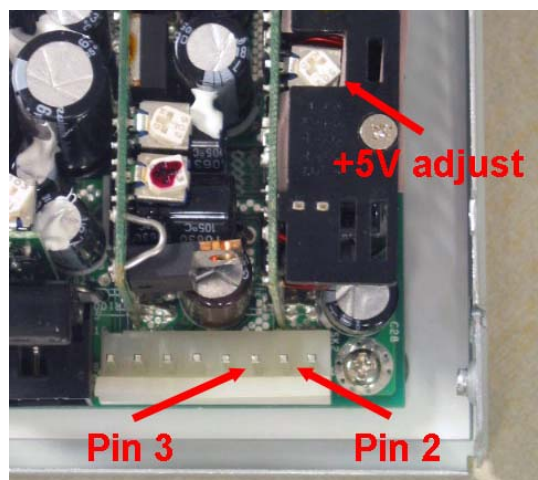
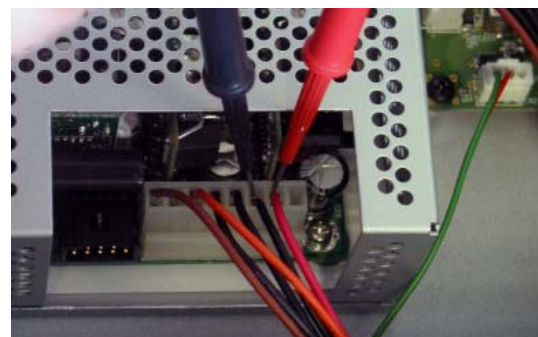
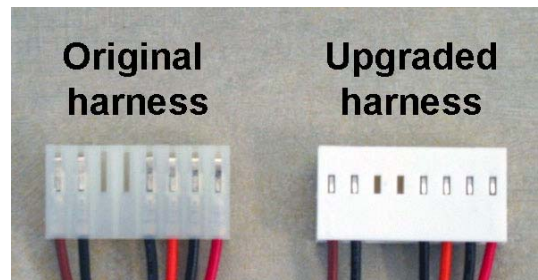



# TROUBLESHOOTING

Symptom	Possible Solution
No Power	<ul style="list-style-type: none"> <li>• Turn power on, plug in power cord.</li> </ul>
Power is on, but no sound	<ul style="list-style-type: none"> <li>• Verify that there is an input signal from the source. The audio input indicator should be green (or yellow).</li> <li>• Verify that there is an output signal. The audio output signal indicator should be green (or yellow).</li> <li>• If there is an input signal (indicator green) and no output signal (indicators off), the ESP-88 may be muted, output levels may be down, or the unit may be completely un-programmed. Run ControlSpace™ Designer software and connect to the ESP-88 and verify. Signals should be passing from inputs to outputs.</li> </ul>
Power is on, but sound is low	<ul style="list-style-type: none"> <li>• Verify that the audio input indicator is green. If it is off, increase the source output or use the Designer software to increase the input gain.</li> <li>• If the audio input indicator is green and the audio output signal indicator is green, verify there is enough gain on the amplifier.</li> </ul>
Sound is distorted	<ul style="list-style-type: none"> <li>• Verify that the audio input signal indicators are not solid red or flashing red. If they are, reduce the source output level or use the Designer software to reduce the input gain.</li> <li>• Verify that the audio output signal indicators are not solid red or flashing red. If they are, and the input indicators are green, use the Designer software to reduce the output gain or any intermediary gain in the signal path.</li> <li>• If the input source signal is clean when it enters the ESP system, and the input and output indicators are green, verify that the loudspeakers are not being overdriven and are not damaged.</li> </ul>
Unnatural sound	<ul style="list-style-type: none"> <li>• Verify that the correct EQ and/or crossover is used in the signal path.</li> </ul>
Status LED is off	<ul style="list-style-type: none"> <li>• Power is off or netlist is not loaded. Use ControlSpace Designer software to load a netlist/configuration.</li> </ul>
Ethernet LED is off	<ul style="list-style-type: none"> <li>• Verify that the ESP LAN port is connected to a PC with a crossover cable.</li> <li>• Verify that the Ethernet LAN connection on the PC is enabled. If it is not enabled, the link LED on the PC will probably be off.</li> <li>• If connected to a hub or switch, check that device's Link LED.</li> <li>• If connected to a hub or switch, verify that the ESP and PC are connected with straight-through cables to the hub or switch.</li> </ul>
Ethernet LED is on, but cannot communicate with the ESP-88	<ul style="list-style-type: none"> <li>• Verify that the LAN settings on the Ethernet device you are using on the PC are set correctly:               <ul style="list-style-type: none"> <li>– Internet Protocol (PCP/IP) is installed as a protocol on this device</li> <li>– IP address is set to 192.168.0.1</li> <li>– Subnet mask is set to 255.255.255.0</li> </ul> </li> <li>• Verify that there is not another LAN connection enabled.</li> <li>• Verify there is not another ESP connected with the same address. If unsure, disconnect one, scan for the remaining unit, and change its address. Repeat with the second unit.</li> </ul>

# SERVICE MANUAL REVISION HISTORY

<b>Date</b>	<b>Revision Level</b>	<b>Description of Change</b>	<b>Change Driven By</b>	<b>Pages Affected</b>
3/06	00	Document released at revision 00.	Service manual release	All
1/08	01	Added part numbers for RoHS versions.	RoHS	12-18
8/08	02	Added part number for new Surround Sound expansion card.	New accessory	5, 16
5/09	03	Added +5V power supply adjustment procedures	New information	105, 106

SPECIFICATIONS AND FEATURES SUBJECT TO CHANGE WITHOUT NOTICE

---

***BOSE***<sup>®</sup>  
***Better sound through research***<sup>®</sup>

Bose Corporation  
The Mountain  
Framingham Massachusetts USA 01701

P/N: 286448-SM Rev. 03 8/2008 (P)  
<http://serviceops.bose.com>