

AmPlus™ 100 and AmPlus 50 Business Music Amplifiers

Installer's Guide

BOSE





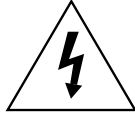

WARNING: These business music amplifiers are electrical appliances. To reduce the risk of fire or electric shock, do not expose the amplifier to rain or moisture; do not disassemble the amplifier. There are no user-serviceable parts inside. Refer servicing to qualified service personnel.
The caution markings described here appear on the top of the amplifier.



The lightning flash with arrowhead symbol, within an equilateral triangle, signifies the presence of uninsulated dangerous voltage within the system enclosure that may be of sufficient magnitude to constitute a risk of electrical shock.

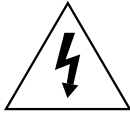

The exclamation point, within an equilateral triangle, as marked on the system, signifies the presence of important operating and maintenance instructions in this guide.

	CAUTION RISK OF ELECTRICAL SHOCK DO NOT OPEN	
<p>CAUTION: TO REDUCE THE RISK OF ELECTRIC SHOCK, DO NOT REMOVE COVER (OR BACK). NO USER-SERVICEABLE PARTS INSIDE. REFER SERVICING TO QUALIFIED PERSONNEL.</p>		

1. **Read, Follow, and Save All Instructions** – Read the complete safety and operating instructions for all components before using this product. Follow all instructions. Save the instructions for future reference.
2. **Pay Attention to Warnings** – Observe all warnings on the product and in this guide.
3. **Do Not Use Near Water or Moisture** – Do not use this product near a bathtub, washbowl, kitchen sink, laundry tub, in a wet basement, near a swimming pool, or anywhere else that water or moisture is present.
4. **Attachments** – Do not use attachments not recommended by Bose® Corporation as they may cause hazards.
5. **Maintain Proper Ventilation** – To ensure reliable operation of the product and to protect it from overheating, put the product in a position and location that will not interfere with its proper ventilation. Do not put it in a built-in system, such as a bookcase or a cabinet, that may keep air from flowing through its ventilation openings.
6. **Avoid Excessive Heat** – Do not put the product near heat sources such as radiators, stoves, or other appliances that produce heat.
7. **Use Proper Power Sources** – Plug the product into a proper power source, as described in the operating instructions or as marked on the product.
8. **Avoid Overloading** – To prevent the risk of fire or electric shock, do not overload wall outlets, extension cords, or integral convenience receptacles.
9. **Be Careful with Accessories** – Mount the product only as recommended by Bose Corporation. Do not put this product on an unstable cart, stand, tripod, bracket, or table. The product may fall, causing serious injury to a person or damage to the product. For advice on use of a particular cart, stand, tripod, bracket, or table, contact Bose Corporation.



If you must move your product and cart combination, do so very carefully. Quick stops, excessive force, and uneven surfaces may cause it to overturn.

- 10. Protect the Power Cord** – Route all power supply (mains) cords so that they are not likely to be walked on or pinched. Pay particular attention to cords at plugs, at outlets on the product, and at the point where the cord connects to the product.
- 11. Take Precautions against Lightning and Power Line Surges** – To prevent damage to this product during a lightning storm, or if the product will not be used for an extended period of time, unplug its power cord from the wall outlet and disconnect the antenna or cable system.
- 12. Obtain Service When It Is Indicated** – The product should be serviced only by authorized service personnel when:
 - A. the power supply cord or the plug has been damaged, or
 - B. objects have fallen or liquid has spilled into the product, or
 - C. the product has been exposed to rain or water, or
 - D. the product does not appear to operate normally or exhibits a marked change in performance, or
 - E. the product has been dropped or the cabinet damaged.
- 13. Do not defeat the safety purpose of the polarized or grounding-type plug** – A polarized plug has two blades with one wider than the other. A grounding-type plug has two blades and a third grounding prong. The wide blade or the third prong are provided for your safety. When the provided plug does not fit into your outlet, consult an electrician for replacement of the obsolete outlet.

General cabling information

Connect high impedance units, such as tape players and CD players, to the amplifier with shielded single conductor cable. Keep cable lengths shorter than 10 feet (3 m).

For output loudspeaker connections, Class II wiring is suggested. Use standard #16 AWG wire.

To minimize hum pick-up or other unwanted effects:

- Keep loudspeaker cables away from power cables.
- Use twisted shielded pairs on microphone inputs.
- Keep input cables away from:
 - Loudspeaker cables to prevent inductive feedback.
 - Power lines or transformers.

AWG	Wire Diameter (in.)	Wire Diameter (mm)	DCR @ 20°C (Ω/1000 ft.)
6	.1620	4.1	.41
8	.1285	3.3	.65
10	.1019	2.6	1.0
12	.0808	2.1	1.6
14	.0641	1.6	2.6
16	.0508	1.3	4.2
18	.0403	1.0	6.6

⚠ CAUTIONS:

Always turn the amplifier power OFF before:

1. Connecting the speakers.
2. Changing the amplifier mode switch.
3. Installing the equalizer and/or option cards.

Never connect the speaker output channels together.

Do not connect the speaker outputs to the chassis or signal ground.

Bose® recommends installation of the amplifier be performed only by an experienced and licensed contractor. Familiarity with standard wiring practices, as recognized by a government agency in your area, is necessary. If you do not have these qualifications, **do not attempt to install this amplifier. Do not wall mount the amplifier.** The amplifier can be desk, shelf, or rack mounted using the rack mount accessory kit.

Warranty period

The following products are covered by a 5-year transferable limited warranty:

- Bose AmPlus™ 100 amplifier and AmPlus 50 amplifier
- Equalizer cards
- Optional cards: Opti-voice® page and Opti-source™ source

Service

If you experience problems with the business music amplifier, contact your authorized Bose Professional Products dealer. The dealer will verify any defects and arrange for service by a factory authorized Bose service agency, or by Bose Corporation. Consult your warranty card for warranty information. An owner's registration card is provided with this manual.

How to use this guide

This guide contains installation information on the AmPlus 100 and AmPlus 50 business music amplifiers. Each amplifier has its own section containing all information about that amplifier. Refer to the table of contents for the location of your amplifier's information.

The AmPlus 100 and AmPlus 50 amplifiers are each available in two versions: A 70V constant voltage audio output version for use with 120V AC mains supply, and a 100V constant voltage audio output version for use with 220-240V AC mains supply. This Installer's Guide includes instructions and specifications for both versions.

- ♪ **Note:** Be sure to leave the **AmPlus 100 Amplifier and AmPlus 50 Amplifier Owner's Guide** with the amplifier or with the owner after completing the installation.

Information You Should Read 2

 General cabling information 3

 Warranty period 4

 Service 4

 How to use this guide 4

Getting Started 6

 What you bought 6

 Amplifier comparison 6

 Installing the amplifier’s feet 6

 Removing the amplifier’s feet 7

 Installing the option cards 7

 Using the quick connectors 7

 Using the loudspeaker output connectors 7

 Setting the levels 7

 Installing the remote control 7

All About The AmPlus™ 100 Amplifier 8

 AmPlus 100 amplifier controls 8

AmPlus 100 Amplifier Configurations 10

AmPlus 100 Amplifier Specifications 15

All About The AmPlus 50 Business Music Amplifier 16

 AmPlus 50 amplifier controls 16

AmPlus 50 Amplifier Configuration 17

AmPlus 50 Amplifier Specifications 18

Bose® Corporation inside back cover

What you bought

The amplifier comes in one box and the accessory kit comes in another.

Figure 1

Product contents

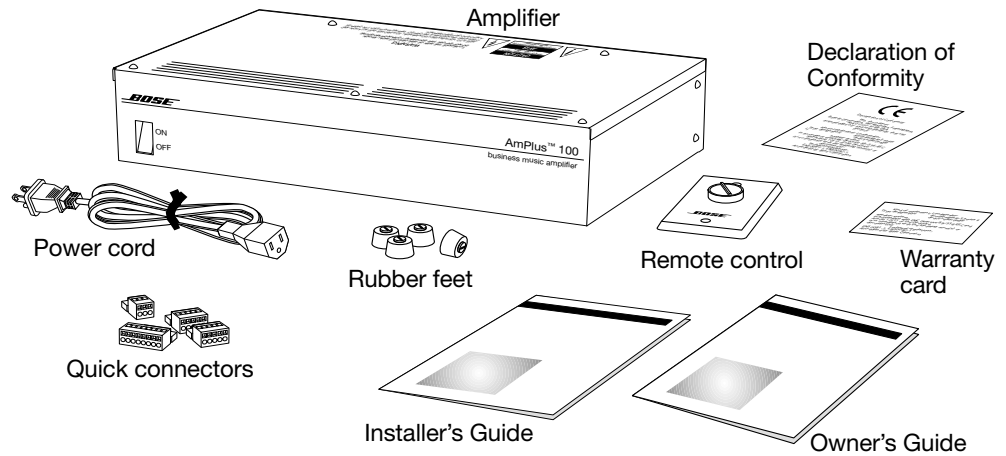

Amplifier comparison

This table shows the major features of the different amplifiers.

Features	AmPlus™ 100 Amplifier	AmPlus 50 Amplifier
Outputs		
Ch1	65W	70W
Ch2	65W	None
70/100V (bridged)	100W	50W
Inputs (balanced)	2	2
Line Outputs (balanced)	2	None
Option Cards		
Paging	Yes	No
A/B Source switching	Yes	No

Installing the amplifier's feet

The amplifier's feet are found in the Accessories box. Use these feet if the amplifier is being placed on a shelf, desk, counter, or any flat surface. The feet elevate the amplifier so air circulates around and through, keeping the amplifier cool.

🎵 **Note:** If the amplifier is going into a rack, DO NOT mount the feet.

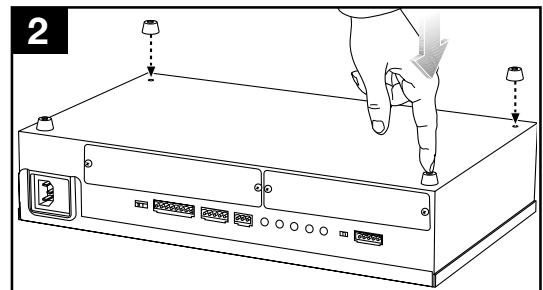
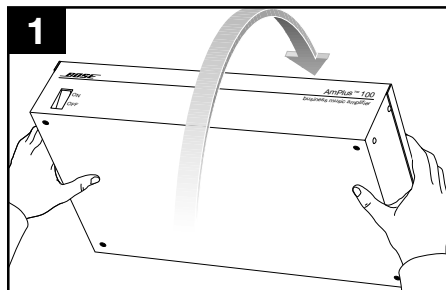

Removing the amplifier's feet

Use a screwdriver to loosen the foot and pull it out.

Installing the option cards

Refer to the installation instructions that come with the equalizer card, Opti-voice® page card, and Opti-source™ source card.

Using the quick connectors

The quick connectors are supplied so you can connect the amplifier to sources and other equipment.

Figure 2

Installing a quick connector

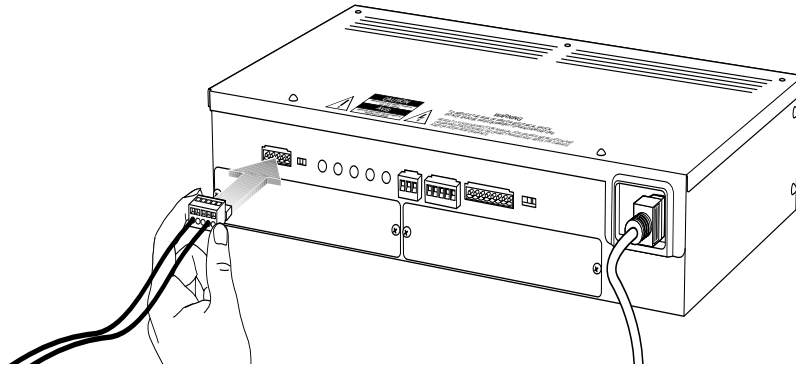

Using the loudspeaker output connectors

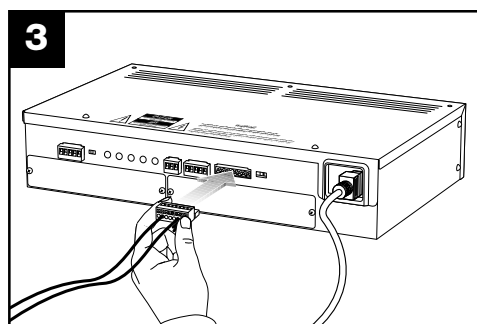
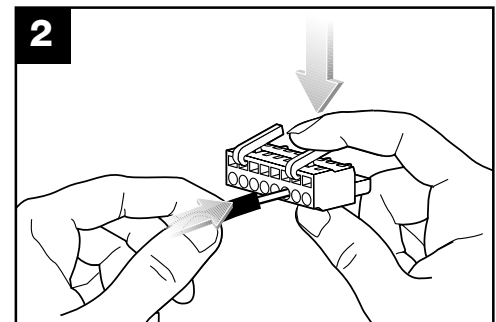
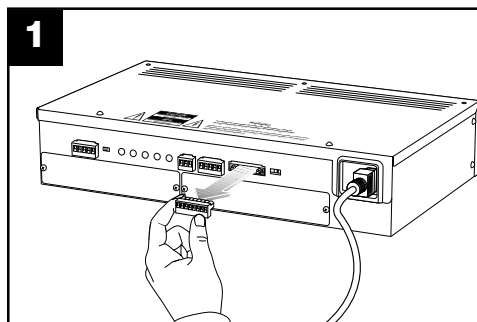

Setting the levels

Each input has its own level control. Use these controls to balance the relative level of each input source. You control overall volume with the remote volume control.

Installing the remote control

The remote control should be wall mounted in an electrical box (not included) similar to a light-switch electrical box. Install the remote control where day-to-day adjustments will be easy to make.

AmPlus 100 amplifier controls

Figure 3

AmPlus 100 amplifier controls

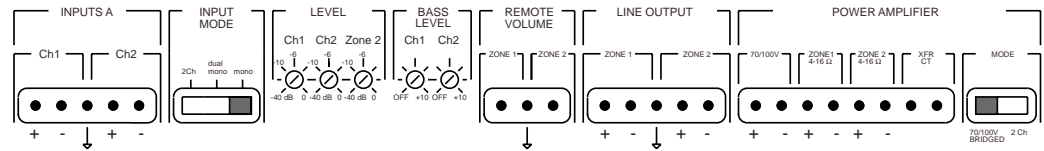

Inputs – The amplifier comes with two balanced inputs. They can be left and right channels from a stereo source or two distinct monophonic (mono) sources for 2-zone applications. Two mono sources can also be “mixed” for single zone applications.

Input Mode – This switch determines how the Channel 1/Channel 2 inputs are presented to the power amplifier section of the AmPlus 100 amplifier. There are three possible modes.

1. In the 2-Channel/Mix position, the inputs remain separate, not summed. Channel 1 and Channel 2 level potentiometers (pots) are active in this mode. Use this mode for:
 - a. Stereo (2-channel).
 - b. Two distinct sources in a two-zone application (2-channel), one source per zone.
 - c. Two distinct sources in a single bridged mono zone (Mix).

♪ **Note:** In Mix mode both sources, Channel 1 and Channel 2, are presented to the amplifier simultaneously. When the internal source mix switch is in the “mix” position (Figure 5), the Channel 1 attenuation controls the source connected to the Channel 1 input. The Channel 2 attenuation controls the source connected to the Channel 2 input.

2. Dual Mono – The Channel 1 and Channel 2 inputs are summed to mono and presented to the amplifiers as one mono signal. This mode may also be used when driving a 70/100V load from the Channel 1 amplifier outputs and a Bose® Model 1B Acoustimass® module from the 4Ω Channel 2 amplifier outputs. See “Zone 2 level adjust”.
3. Mono Mode – Both inputs, Channel 1 and Channel 2, are summed to mono. Only the Channel 1 level pot is active.

Level – Channel 1 level adjust – In 2-channel (stereo) mode, this pot affects the signal level at the Channel 1 low impedance (4Ω) outputs. In dual mono mode, it controls the zone 1 level. In mono mode, it controls the level of all outputs.

Channel 2 level adjust – In 2-channel (stereo) mode, this pot controls the signal level at the Channel 2 low impedance (4Ω) outputs. This pot is not active in dual mono or mono modes.

Zone 2 level adjust – This pot is active only when the input mode is dual mono. In this mode, this pot controls the signal level at the Channel 2 low impedance outputs. This pot is a slave to the Channel 1 pot; that is, the Channel 1 pot controls the level of both zones in a 2-zone system. However, the zone 2 pot can be used to fine-tune the level of the second listening zone without affecting zone 1. This pot may also be used to fine-tune the bass level when using the AmPlus 100 amplifier to drive a 70/100V load connected to the 70/100V output and a Model 1B Acoustimass module connected to the Channel 2 output.

AmPlus 100 amplifier controls (cont'd)

Figure 3 (cont'd)

AmPlus 100 amplifier controls

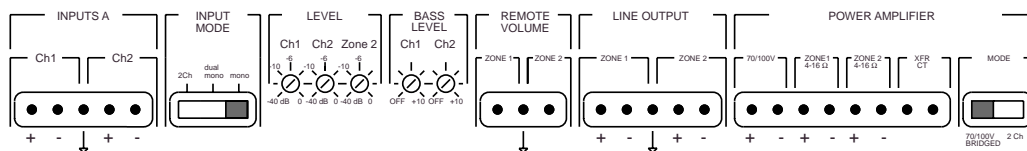

Bass Level – Use the bass level potentiometers (pots) to increase the output level between 50Hz and 150Hz. This is useful for compensating for poor bass cabinet loading or high levels of low-frequency ambient noise. The Channel 1 and Channel 2 pots are active in all modes of operation.

Remote Volume – When using the amplifier to power one listening zone, connect the remote control unit to the zone 1 (+) pin and the ground pin. Set the internal remote volume switch (Figure 4) to 1_REMOTE. When using the AmPlus 100 amplifier for 2-zone applications, connect a second remote to the zone 2 (+) pin and ground pin. Set the internal remote volume switch to 2_REMOTE.

Figure 4

Internal remote volume switch

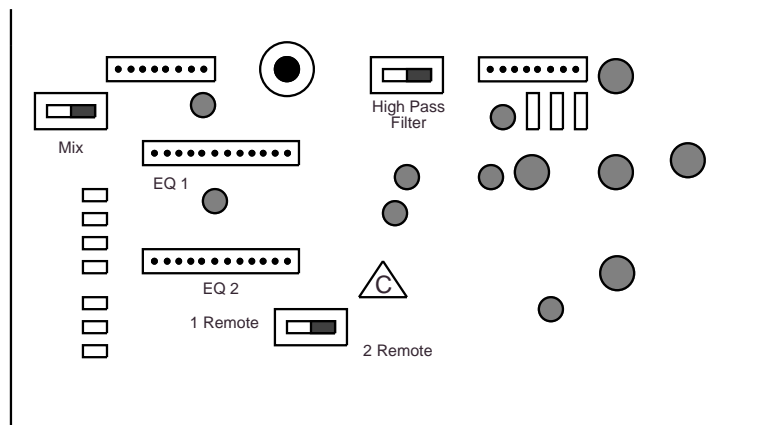

Line Outputs – Both line output responses are flat (regardless of whether or not you have installed active equalizer cards). The remote volume control affects the line output levels. Both outputs are active in stereo mode. Only zone 1 is active in dual mono and mono modes.

Power Amplifier Outputs – The 70/100V output becomes active when the amp mode switch is in the 70/100V position. In this setup, both AmPlus 100 amplifier channels are bridged and provide up to 100W to the 70/100V speaker(s).

When the amp mode is in the 2-channel position and a jumper is placed across the XFR CT pins, 50W is available at the 70/100V output and 65W is available at the channel 2 output.

With the amp mode switch in the 2-channel position, both Channel 1 and Channel 2 supply 65W into a minimum load of 4Ω.

Internal High Pass Switch – When this switch is in the “HPF ON” position, frequencies below 150Hz are attenuated at 18dB/OCT. This low-frequency roll-off occurs on Channel 1 only. Use this switch for bandlimiting high-frequency speakers connected to Channel 1 in a bi-amplified system.

AmPlus 100 Amplifier Direct-coupled Model 1B Installation

English

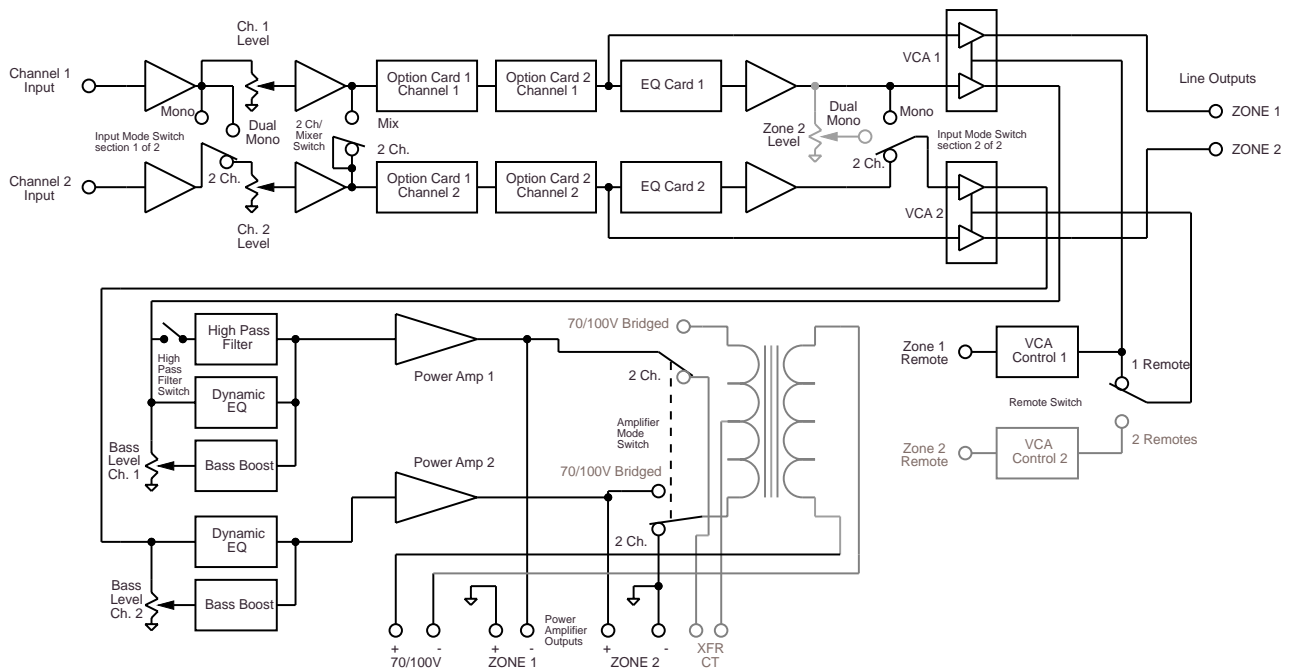
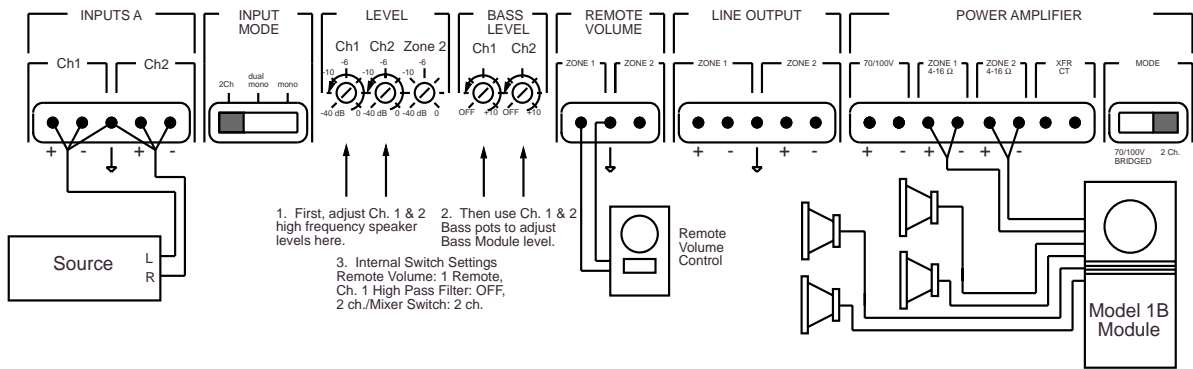
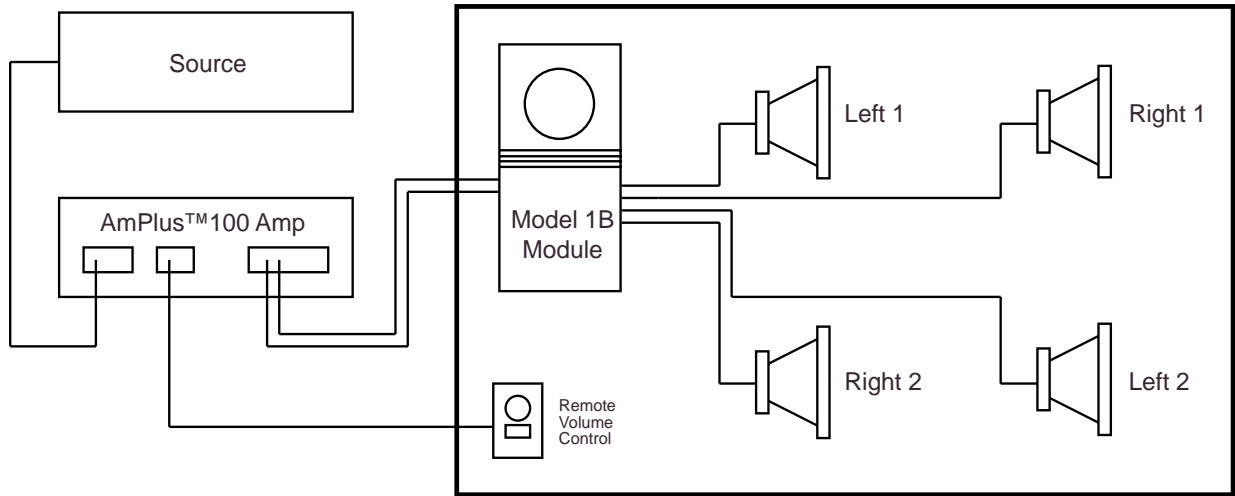

AmPlus 100 Amplifier 70/100V/Model 1B Installation

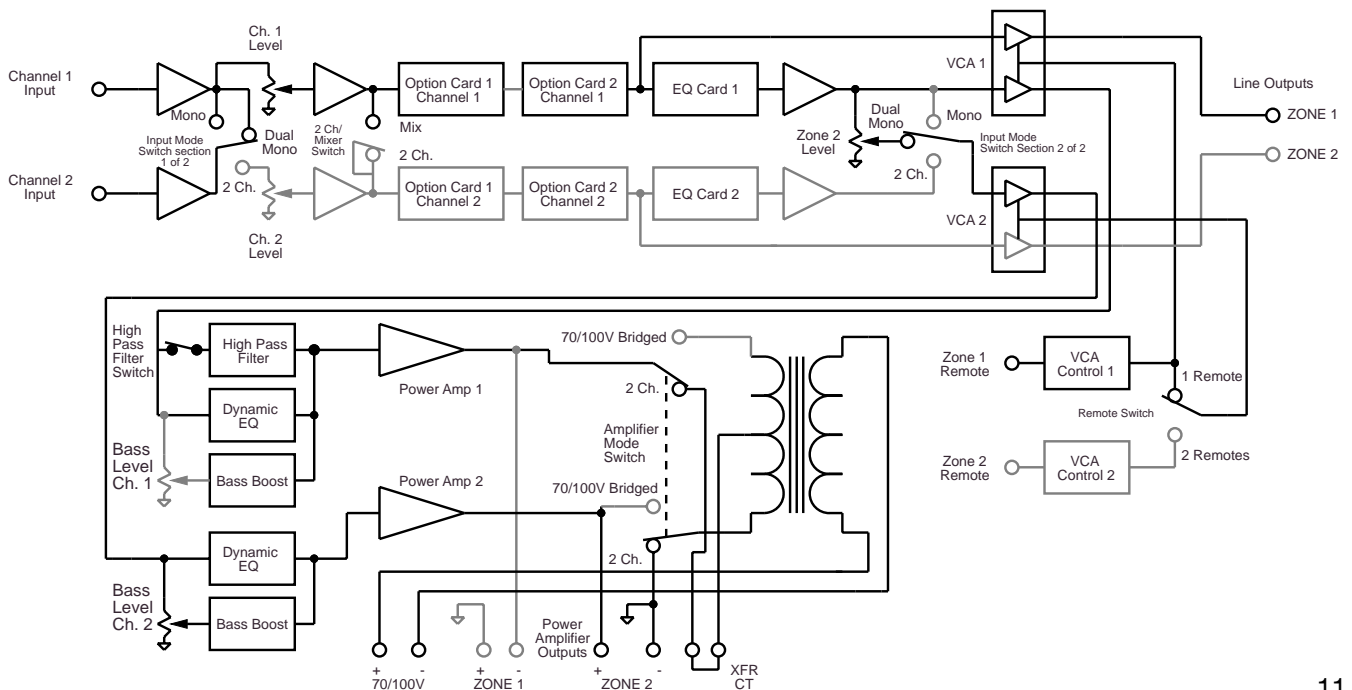
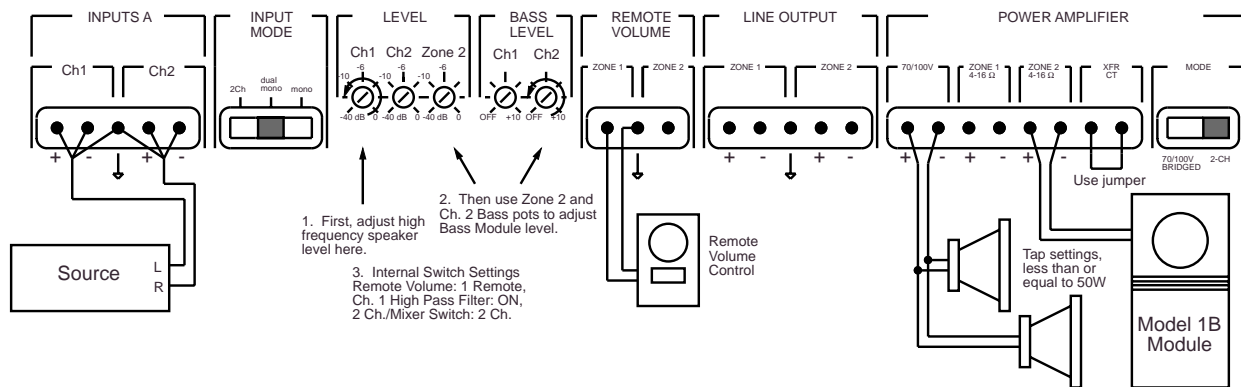
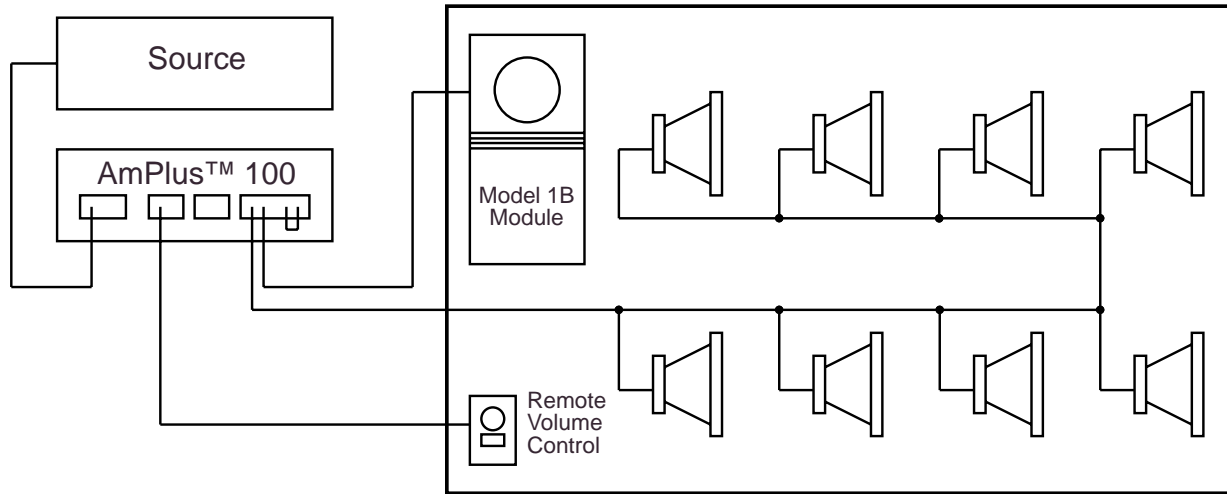

AmPlus 100 Amplifier Simple Monophonic Installation

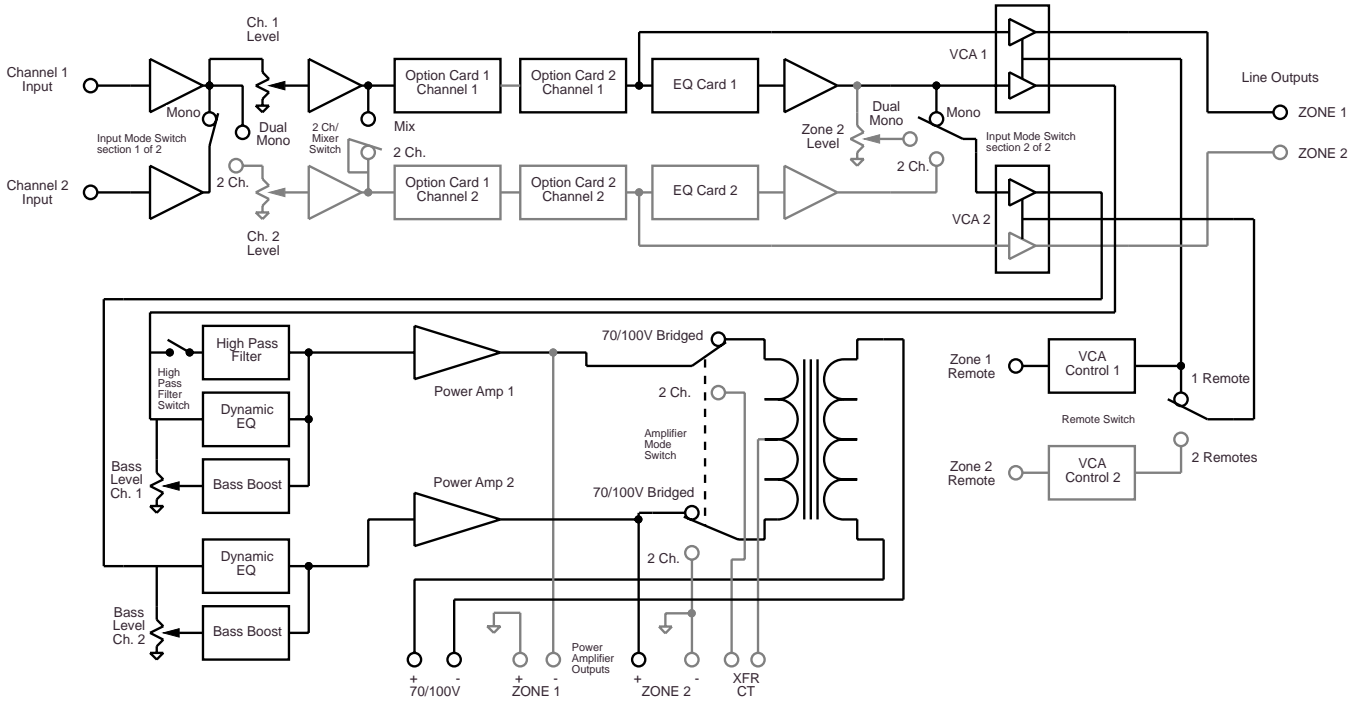
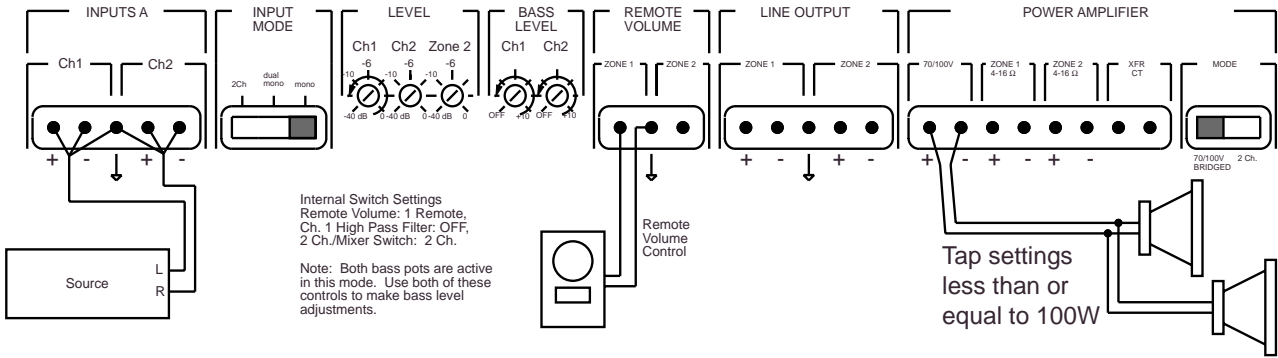
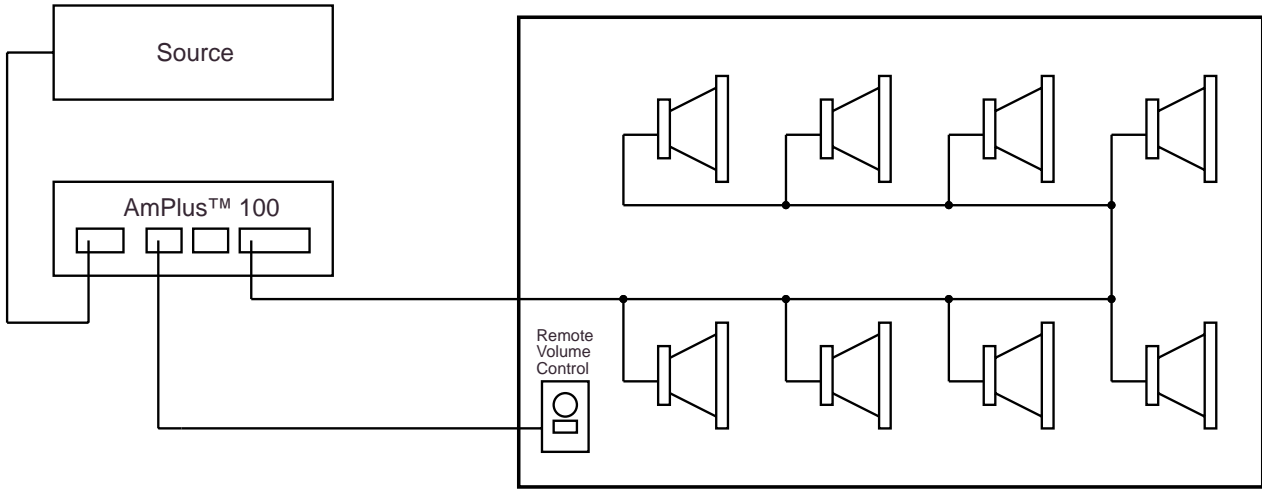

AmPlus 100 Amplifier Large Monophonic Installation

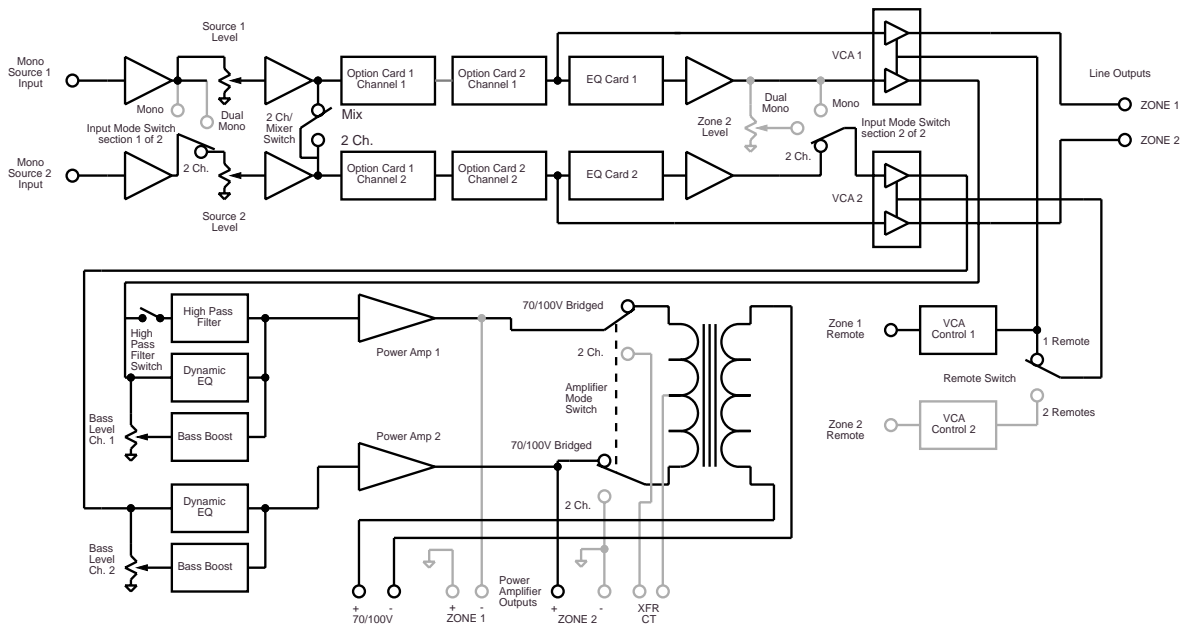
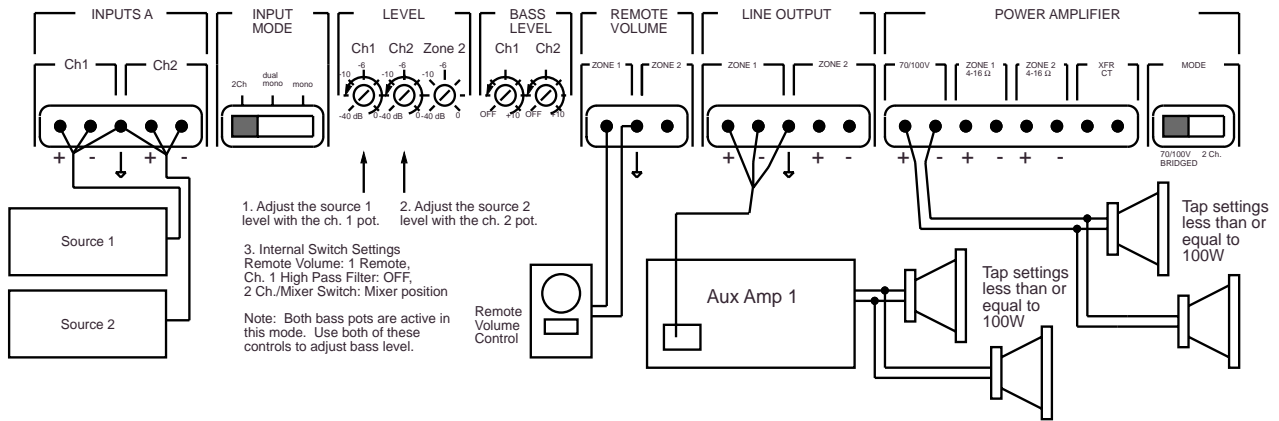
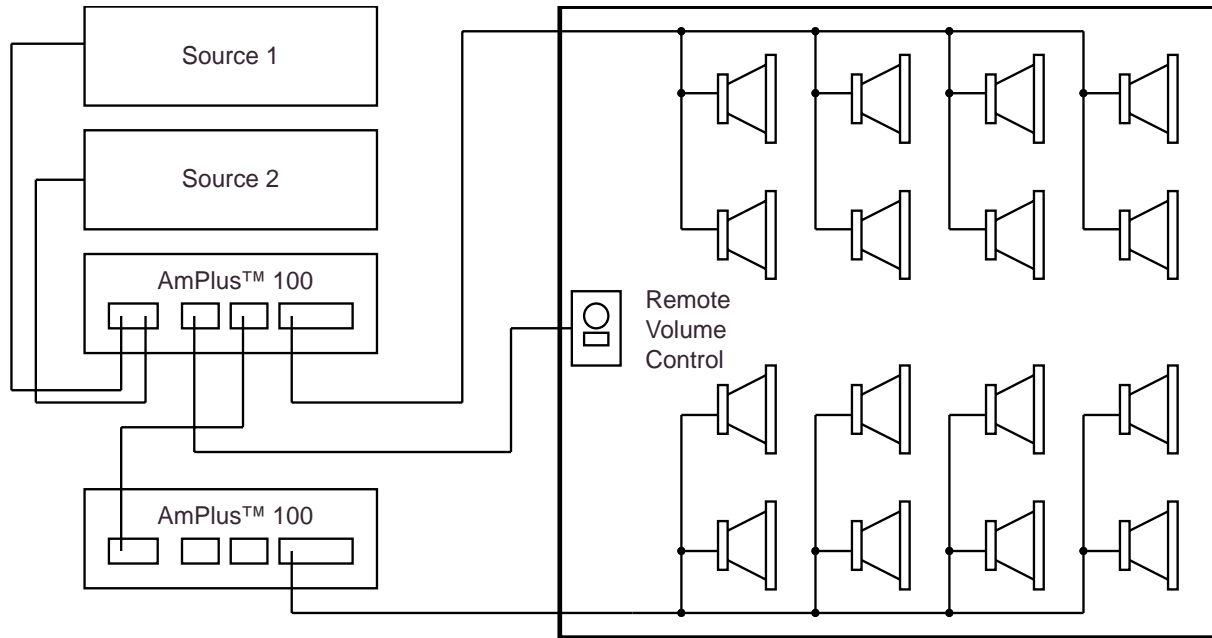

AmPlus 100 Amplifier With Two 70/100V Zones Installation

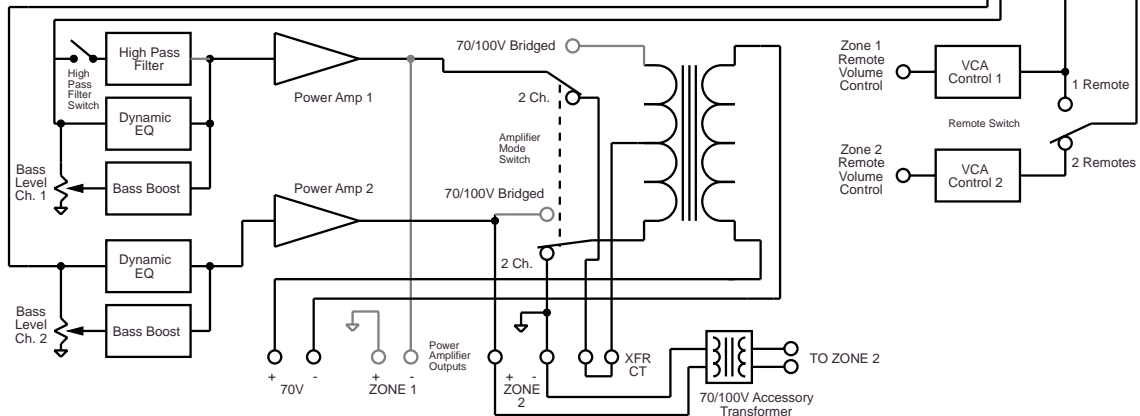
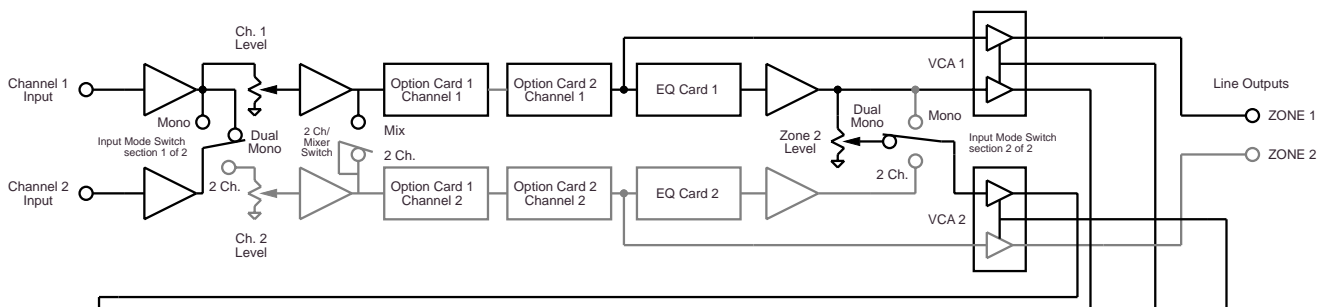
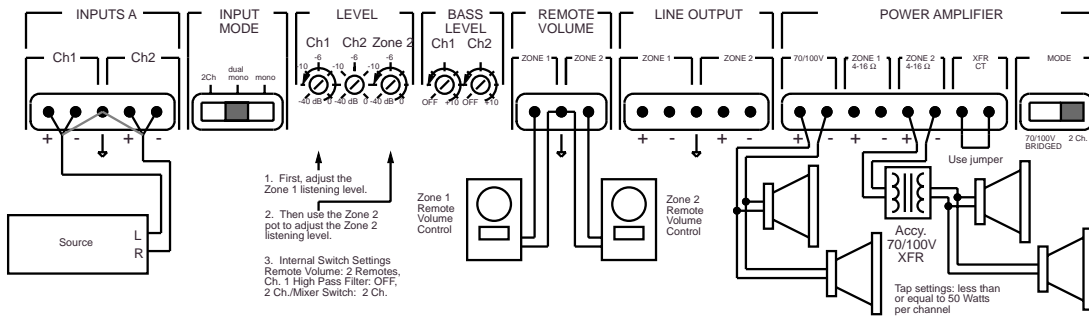
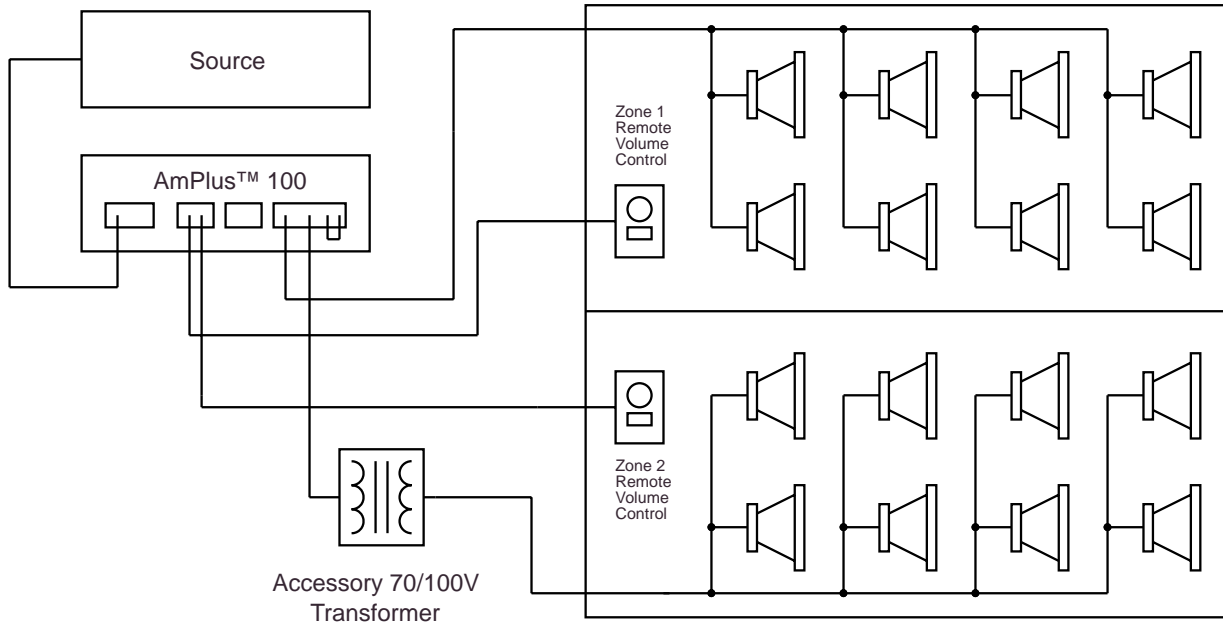

Power output

Stereo: 65W per channel into 4Ω
50W into 8Ω
70V bridged mono: 100W into 49Ω
100V bridged mono: 100W into 98Ω
70V/4Ω: 50W @70V output into 98Ω
65W @Ch2 output into 4Ω
100V/4Ω: 50W @70V output into 196Ω
65W @Ch2 output into 4Ω

Input sensitivity

315mV required to drive both channels to full power in any mode

Input attenuation

0dB to off

Input/Output configurations

1. 2-channel (stereo)
2. Mono into 4Ω load
3. Mono into 70/100V load
4. Dual-Mono (1 source/2 zones)
5. 2-channel (70/100V and 4Ω/Ch2)

Input impedance

32kΩ balanced
11kΩ unbalanced

Line output impedance

600Ω

Line output distortion

≤0.1%

Frequency response (active EQ bypassed)

4Ω outputs: 40Hz – 16kHz, ±1dB
70/100V outputs: 60Hz – 16kHz, ±1dB

THD @ rated power

4Ω outputs: ≤1% THD (40Hz – 16kHz)
70/100V outputs: ≤1% THD (60Hz – 16kHz)

Hum and noise

Line outputs: 92dB
Pwr amp outputs: 80dB below maximum output with 4Ω load

Controls

Inputs 1 and 2, input attenuation, remote volume, bass adjust 1 and 2.
Input mode and amplifier mode switches.
Front panel power switch.

LED indicator

Power: front panel

AC power consumption

120V~AC, 50/60Hz, 350W max
220-240V~AC, 50/60Hz, 350W max

Operating temperature range (passively cooled, top and bottom vents)

12° F to 120° F (-10° C to +50° C)

Special features

Remote volume control
Turn on/off muting
Clip detection and limiter
Short circuit protection
DC offset protection
Thermal limiting
Stable into reactive loads
RFI protection
International safety approvals under UL-6500, CSA-E65, IEC-65
EMC CE compliance

Option card accessories

EQ cards (Model 8 loudspeaker, Model 25 loudspeaker, Model 32 loudspeaker, and Model 1B Acoustimass® module, 402™ loudspeaker, 502® loudspeaker, 802® loudspeaker)
Opti-Source™ card
Opti-voice® page card

Terminations

Inputs and outputs are quick connect terminal blocks

Size

17"W x 10"D x 3¾"H
(43.2 x 25.4 x 9.5 cm)
(desk mount)
19"W x 10"D x 3¾"H
(48.3 x 25.4 x 9.5 cm)
(rack mount, chassis supported)

Weight

20 lb (9.1 kg)

Associated equipment

Rack mount kit
70/100V transformer

AmPlus 50 amplifier controls

Figure 5

AmPlus 50 amplifier controls

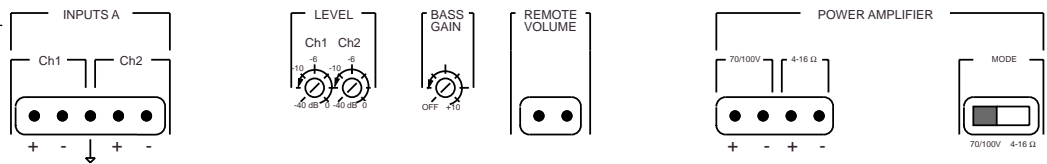

Inputs – The AmPlus 50 amplifier comes with two balanced inputs. They can be left and right from a stereo source; two mono sources can also be mixed. Since the AmPlus 50 amplifier is a single channel amplifier, a stereo source is internally summed to mono.

Level – Channel 1 level adjust – This potentiometer (pot) controls the signal level of the Channel 1 input source.

Channel 2 level adjust – This pot controls the signal level of the Channel 2 input source.

Bass Gain – Use the bass gain pot to increase the output level between 50Hz and 150Hz (affects 50Hz – 150Hz only). This is useful for compensating for poor bass cabinet loading or high levels of low-frequency ambient noise.

Remote Volume – Connect the remote control unit to the zone 1 (+) pin and the ground pin.

Figure 6

Internal remote volume switch

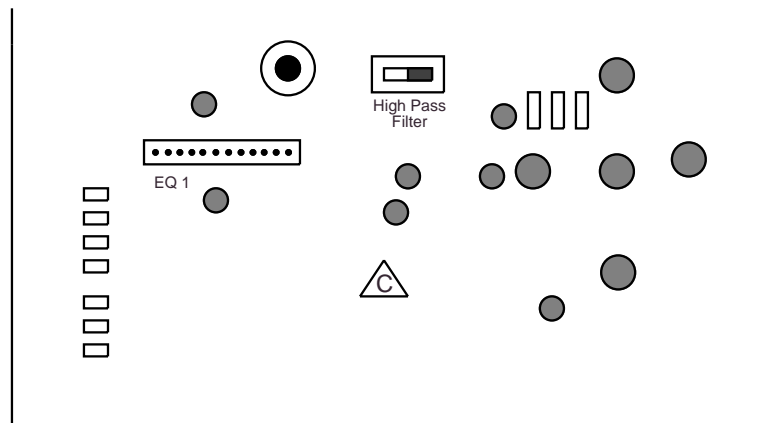

Power Amplifier Outputs – The 70/100V output is active when the amplifier Mode Switch is in the 70/100V position. The 4Ω output is active when the amplifier Mode Switch is in the 4Ω position.

Internal High Pass Switch – When this switch is in the “HPF ON” position, frequencies below 150Hz are attenuated at 18dB/OCT. Use this switch for band-limiting high-frequency speakers in a bi-amplified system.

AmPlus 50 Amplifier Simple Monophonic Installation

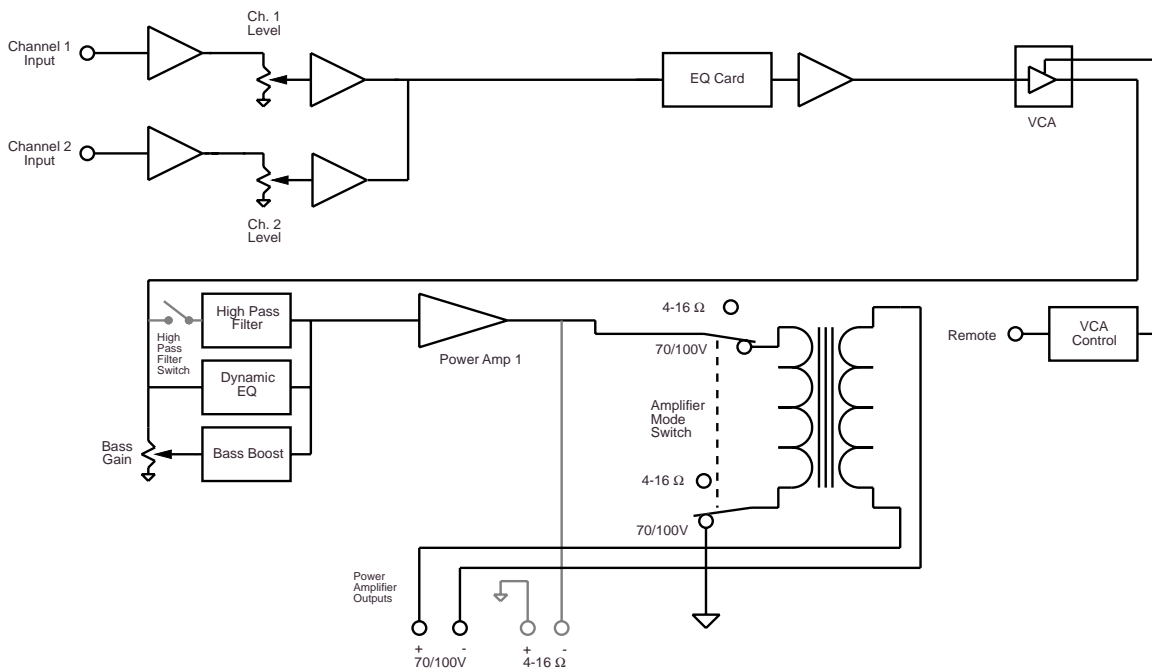
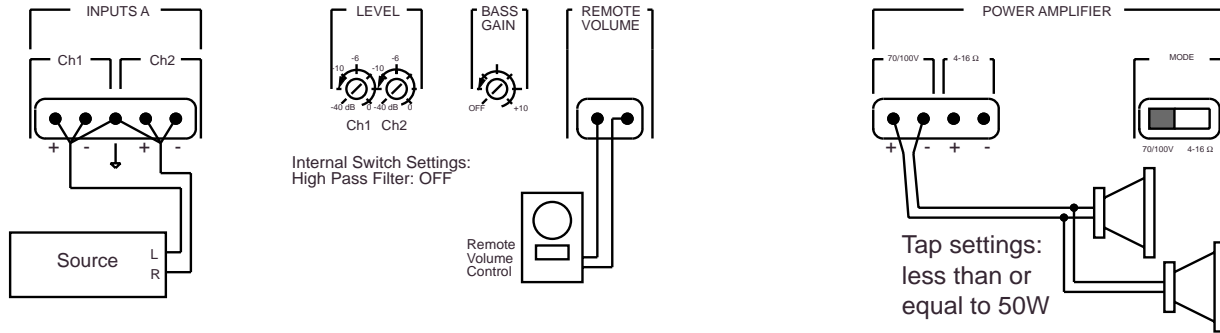
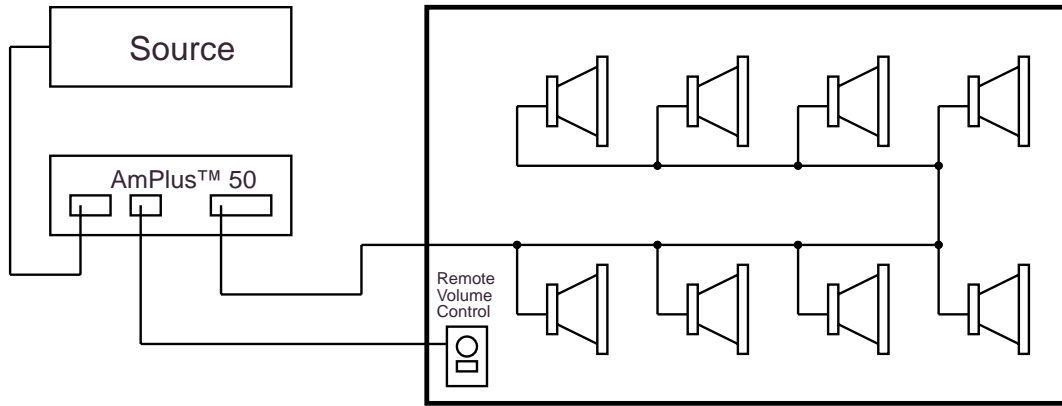

Power output

70V mono: 50W into 98Ω
 100V mono: 50W into 196Ω
 4Ω mode: 70W into 4Ω

Input sensitivity

315mV required to drive both channels
 to full power in any mode

Input attenuation

0dB to $-\infty$

Input/Output configurations

1. Mono into 4Ω load
2. Mono into 70/100V load
3. As an extension to the AmPlus 100 amplifier

Input impedance

32kΩ balanced
 11kΩ unbalanced

Line output impedance

600Ω

Line output distortion

≤0.1%

**Frequency response
(active EQ bypassed)**

4Ω outputs: 40Hz – 16kHz, ±1dB
 70/100V outputs: 60Hz – 16kHz, ±1dB

THD @ rated power

4Ω outputs: ≤1% THD (40Hz – 16kHz)
 70/100V outputs: ≤1% THD
 (60Hz – 16kHz)

Hum and noise

Power amplifier outputs: 80dB below
 maximum output with 4Ω load

Controls

Inputs 1 and 2, input attenuation, remote
 volume, bass adjust effects bandwidth of
 50Hz – 150Hz by 0 – 10dB.

Amplifier mode switch.

Front panel power switch.

LED indicators

Power: front panel

AC power consumption

120V~AC, 50/60Hz, 200W max
 220-240V~AC, 50/60Hz, 200W max

**Operating temperature range
(passively cooled, top and
bottom vents)**

12° F to 120° F (-10° C to +50° C)

Special features

Remote volume control
 Turn on/off muting
 Clip detection and limiter
 Short circuit protection
 DC offset protection
 Thermal limiting
 Stable into reactive loads
 RFI protection
 International safety approvals under
 UL-6500, CSA-E65, IEC-65
 EMC CE compliance

Option card accessories

EQ cards: (Model 8 loudspeaker,
 Model 25 loudspeaker, Model 32
 loudspeaker, Model 1B Acoustimass®
 module)

Terminations

Inputs and outputs are quick connect
 terminal blocks

Size

17"W x 10"D x 3¾"H
 (43.2 x 25.4 x 9.5 cm)
 (desk mount)

19"W x 10"D x 3¾"H
 (48.3 x 25.4 x 9.5 cm)
 (rack mount, chassis supported)

Weight

20 lb (9.1 kg)

Associated equipment

Rack mount kit

USA

Bose Corporation, The Mountain
 Framingham, MA 01701-9168
 1-800-288-BOSE (1-800-288-2673)
 Phone hours – ET (eastern time):
 Weekdays 9 a.m. to 8 p.m.
 Saturdays 9 a.m. to 3 p.m.

Canada

Bose Ltd., 1-35 East Beaver Creek Road
 Richmond Hill, Ontario L4B 1B3
 1-800-444-BOSE (1-800-444-2673)
 Phone hours – ET (eastern time):
 Weekdays 9 a.m. to 5 p.m. ET

European Office

Bose B.V., Nijverheidstraat 8
 1135 GE Edam, Nederland
 TEL 0299-390139 FAX 0299-390109

Australia

Bose Australia, Inc., 1 Sorrell Street
 Parramatta, N.S.W. 2150
 TEL 02 204-6111 FAX 02 204-6122

Belgique/België

Bose N.V., Limesweg 2, B-3700 Tongeren
 TEL 012-390800 FAX 012-390840

Danmark

Bose A/S, Industrivej 7, 2605 Brøndby
 TEL 4343-7777 FAX 4343-7818

Deutschland

Bose GmbH, Max-Planck-Straße 36d
 D-61381 Friedrichsdorf
 TEL 06172-71040 FAX 06172-710419

France

Bose S.A., 6, rue Saint Vincent
 78100 Saint Germain en Laye
 TEL 01-3061-6363 FAX 01-3061-4105

India

Bose Corporation India Private Limited
 W-16, Greater Kailash-II
 New Delhi 110 048
 TEL (011) 648-4462 FAX (011) 648-4463

Ireland

Bose Corporation
 Carrickmacross, Co Monaghan
 TEL 042-61988 FAX 042-61998

Italia

Bose S.p.A., Via Luigi Capucci, 12
 00147 Roma
 TEL 06-5127641 FAX 06-5115438

Japan

Bose K.K., Shibuya YT Building
 28-3 Maruyama-cho
 Shibuya-ku, Tokyo 150
 TEL 3-5489-1054 FAX 3-5489-0591

Nederland

Bose B.V., Nijverheidstraat 8
 1135 GE Edam
 TEL 0299-390139 FAX 0299-390109

Norge

Bose A/S, Solheimsgate 11
 N-2001, Lillestrøm
 TEL 63-817380 FAX 63-810819

Österreich

Bose Ges.m.b.H., Vienna Business Park
 Wienerbergstrasse 7 (10.OG)
 A-1100 Vienna
 TEL 01-60404340 FAX 01-604043423

Schweiz/Suisse

Bose AG, Rünenbergerstrasse 13
 4460-Gelterkinden
 TEL 061-9815544 FAX 061-9815502

Sverige

Bose A/S, Blandsädsgratan 2D
 S-43146 Mölndal
 TEL 031-878850 FAX 031-274891

United Kingdom

Bose Limited, Unit G2
 Trinity Trading Estate
 Sittingbourne, Kent ME10 2PD
 TEL 01795-475341 FAX 01795-427227

From other locations

Bose Customer Service, 1 New York Avenue
 Framingham, MA 01701-9168 USA
 TEL (508)766-1900 FAX (508)766-1919

World Wide Web

www.bose.com

