

SAFETY CONTROLLED

ControlSpace EX 1280C
 PSTN PCB Assembly
 PCB P/N: 772582-001S
 Schematic Diagram, Rev. A
 Sheet 1 of 4

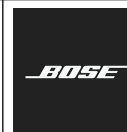

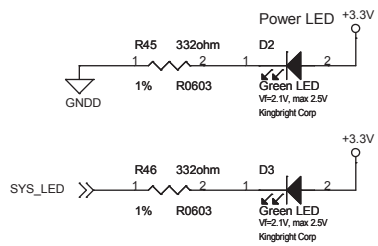
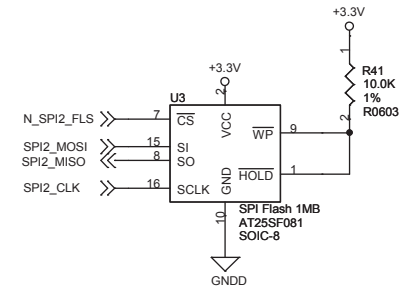
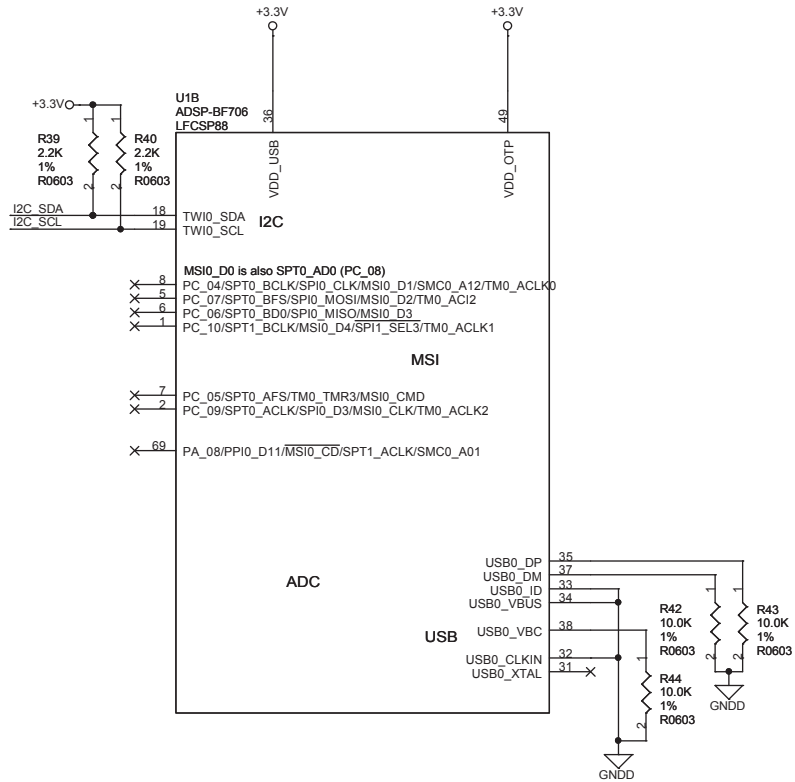

SAFETY CONTROLLED

ControlSpace EX 1280C
 PSTN PCB Assembly
 PCB P/N: 772582-001S
 Schematic Diagram, Rev. A
 Sheet 2 of 4



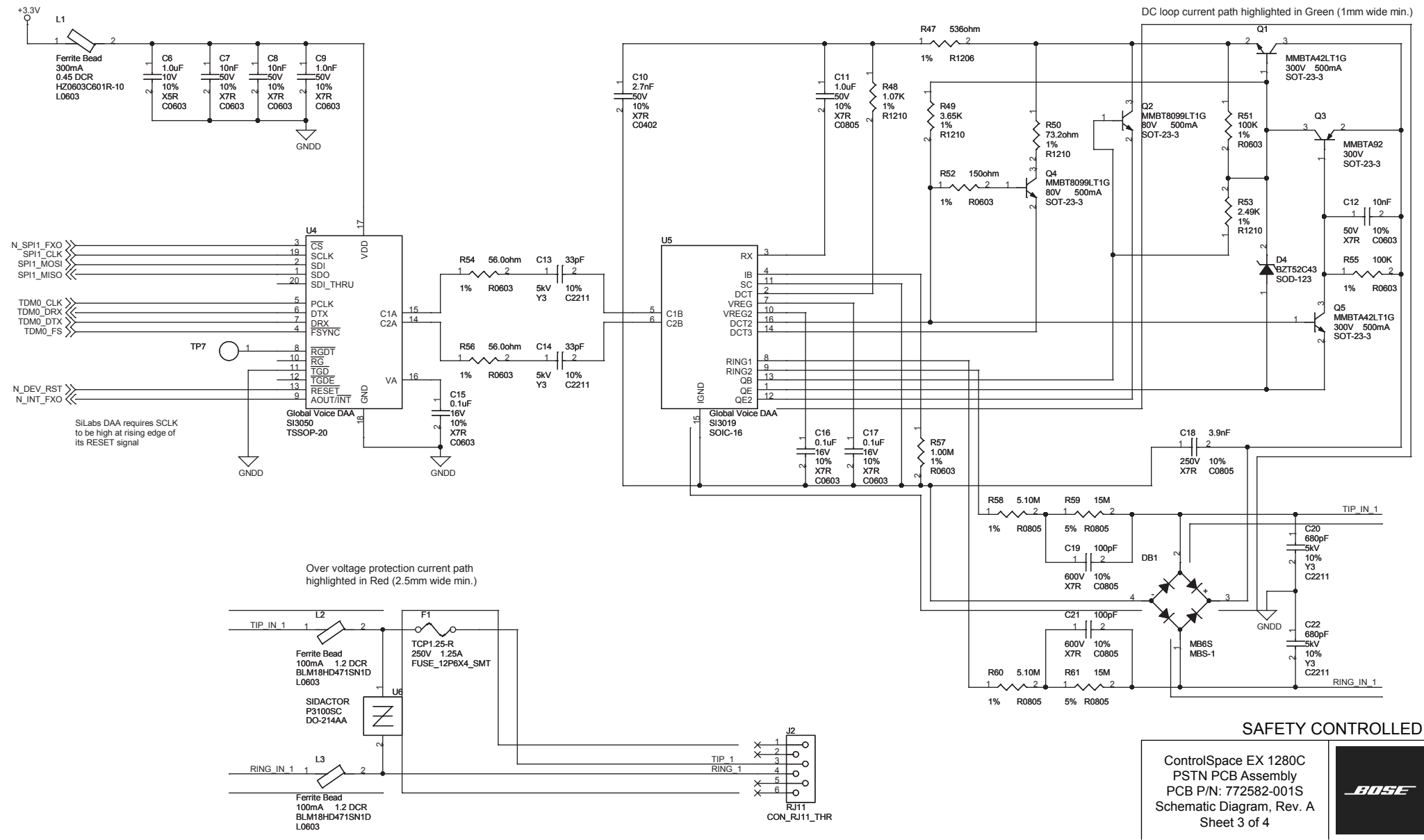

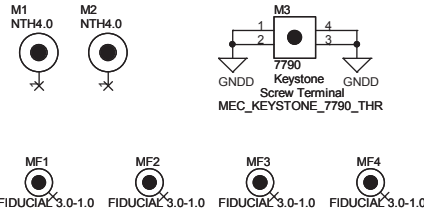
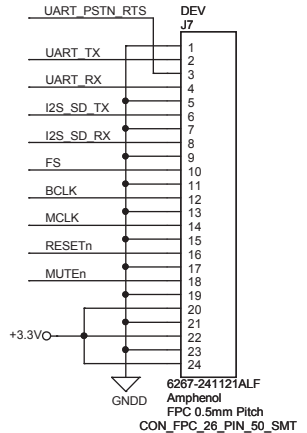
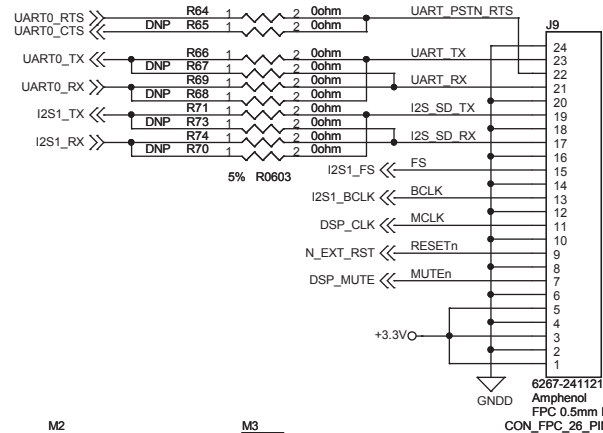
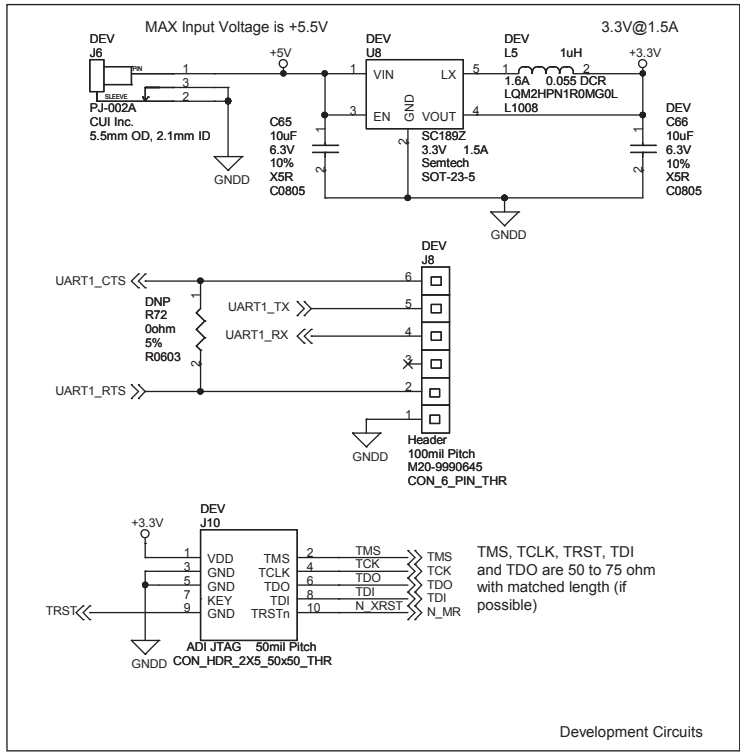
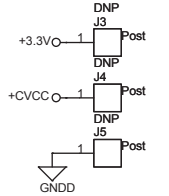
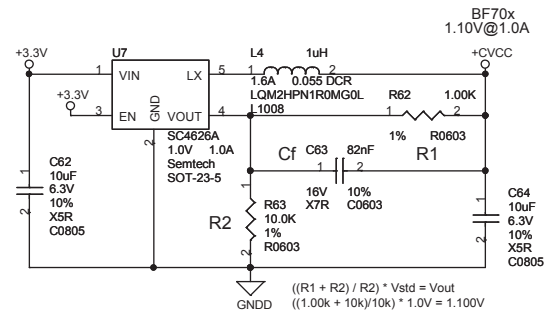
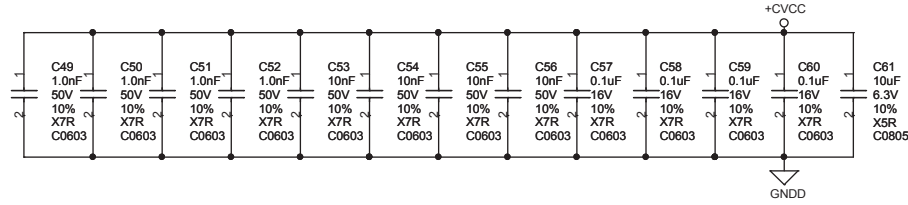
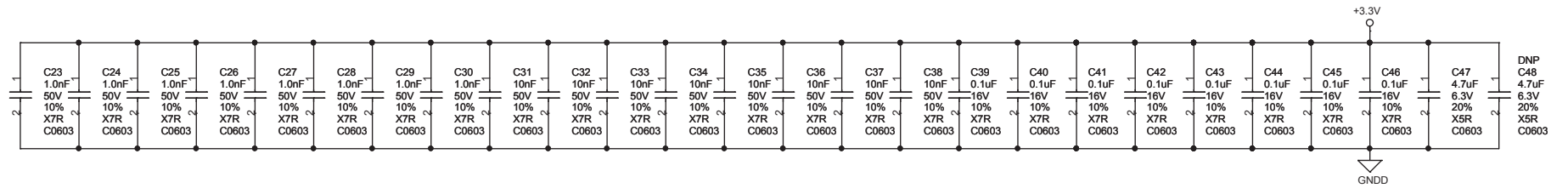

SAFETY CONTROLLED

ControlSpace EX 1280C
PSTN PCB Assembly
PCB P/N: 772582-001S
Schematic Diagram, Rev. A
Sheet 4 of 4

